



# MODULE A - AWNINGS, PATIOS & CARPORTS ENGINEERING & CONSTRUCTION MANUAL NON CYCLONIC & CYCLONIC REGIONS



*Australian Made For An Australian Lifestyle*

## ENGINEER CERTIFICATION

Awnings, Patios and Carports, that are installed in accordance with these documents, pages 1 to 88 inclusive, issued by Delta Panels Pty Ltd are certified to be structurally adequate and accordance to relevant Australian Standards but not limited to, AS 1170.0, AS 1170.1, AS 1170.2, AS 4055, AS 1684.2, AS 1720.1, AS 2870, AS 3600, AS 3700, AS 4100, AS 4600, AS 1562.1, AS 4040.3 and will comply and meet performance requirements in accordance with NCC 2022.

J S George Meija  
BE. B Com CPEng MIE Aust  
Registered Professional Engineer Qld 742  
Registered Builder Qld 2862  
1/5 Golden Crest Place  
Bellbowrie Qld 4070

Signed:

George J S Meija

**Delta Panels Pty. Ltd.**

ABN: 11 147 861 292

**Document No. 180509**

Version Date: 2024-10-01

E: [info@deltapanel.com](mailto:info@deltapanel.com)  
W: [www.deltapanel.com](http://www.deltapanel.com)

Head Office:  
731 Boundary Road, Richlands, Qld 4077  
P: +61 07 3271 2170

Sydney Depot:  
11 The Old Northern Road, Narellan, NSW 2567  
P: +61 2 4611 7712



SCI QUAL  
INTERNATIONAL



SCI QUAL  
INTERNATIONAL



SCI QUAL  
INTERNATIONAL

## PREFACE

The Delta Panels™ Engineering Manual is divided into five (5) separate modules. Each module covers a different product type and the engineering calculations specifically associated with those products.

### MODULE A - AWNINGS, PATIOS & CARPORTS

The module covers roofs which are either attached to an existing building primarily a dwelling or to a separate standalone structure. The engineering calculations encompass both single skin and insulated roofing and is divided into both DeltaSingle™ and DeltaSpan™ span tables.

### MODULE B - PRE-ENGINEERED KITS

The Engineering for this series of structures is presented in kit forms covering single and double awnings, patios & carports with various options regarding footing types. This module covers engineering for DeltaSpan™ roofing in both cyclonic and noncyclonic regions. Any other configuration that is not covered by the engineering in this module would require site specific engineering calculations.

### MODULE C - GABLES

The Gable Engineering module encompasses two (2) different styles of Gables, namely KingPost and KingPost-Eco. The engineering tables are presented with various options on roof pitch and the associated post, beam and fixing requirements.

### MODULE D - BRACKETS AND FIXINGS

This module lists all of the associated brackets and fixings that have been tested and approved for use. These brackets and fixings are an integral part of the Delta Panels™ Engineering Manual.

### MODULE E - RESIDENTIAL ROOFING

The Module E - Residential Roofing module covers the spans and permissible overhangs that Delta Panels insulated roofing products are certified for in both single & multi-span applications. These calculated spans are shown for both non-cyclonic and cyclonic zones.

# ENGINEERING NOTES

## GENERAL NOTES

The information contained in this Engineering & Construction Manual is specifically designed to suit the range of freestanding and attached Delta Patio™ and Carports which have been engineered with an option of either Single Skin or Insulated Roofs.

A Patio/Carport is considered to be a freestanding structure unless it's attached to an existing structure for at least 50% of its shortest side.

The information contained in this Engineering manual relates specifically to products supplied by Delta Panels Pty Ltd™. Any products not approved by Delta Panels Pty Ltd™ will void Engineering Approvals and Warranties expressed or implied.

All assembly, connection and installation procedures must comply with the Delta Panels™ standards as set out in the Engineering & Construction Manual

## SITE SAFETY

It is the Builder/Owner's responsibility to ensure that any existing structure that the Delta Patio/Carport is to be attached to, is adequately reinforced to accommodate all additional loads created by the new Delta Patio/Carport. Prior to any footings being commenced it is the Builder/Owner's responsibility to ensure that the footings will not impact on any existing underground services and facilities.

## CONCRETE/FOOTINGS

For any connections to an existing concrete slab, it is the Builder/Owner's responsibility to ensure that the slab is structurally adequate to support the additional load.

- Concrete strength must be a minimum of N25 in accordance with AS 1379-2007.
- The slab must cover the full width of the roof and reinforced with F62 mesh or greater
- For footings with depth deeper than 500mm, reinforce the footings with 4 x Y12 Vertical rods - ties with R6 LIGS500 centres.
- Hold down capacities apply to piers with an undercut into cohesive clay soils. They are not applicable in sandy soils which must be referred to an Engineer.

## STEEL COMPONENTS

All steel structural components of the Delta Panels™ Patio & Carport systems are in accordance with these Australian Standards:

DeltaSingle™ Steel Skin	AS 1397-2011
Delta Insulated Panel Top Skin	AS 1397-2011
Delta Insulated Panel Bottom Skin	AS 1397-2011
Delta Beams™	AS 1397-2011
Posts (Square Hollow Sections)	AS 1163-2016

## FIXINGS

All fixing components of the Delta Panels™ Patio & Carport systems are in accordance with these Australian Standards

Bolts shall be grade 4.6 or better	AS 1110.1-2015
Fixing Screws shall be class 3	AS 3566-2002

## GLOSSARY

<b>DeltaSpan™</b>	A registered name covering the range of Delta Panels™ insulated roofing products, DeltaTrim™, DeltaOrb™, DeltaCorroCorro™, DeltaTrimTrim™ & DeltaTrimCorro™
<b>DeltaSingle™</b>	A registered name for Delta Panels™ single skin roofing sheet
<b>DeltaTrim™</b>	A registered name for Delta Panels™ insulated roof product with a trapezoid formed top skin
<b>DeltaOrb™</b>	A registered name for Delta Panels™ insulated roof product with a corrugated formed top skin
<b>DeltaCorroCorro™</b>	A registered name for Delta Panels™ insulated roof product with a corrugated formed top and bottom skin
<b>DeltaTrimTrim™</b>	A registered name for Delta Panels™ insulated roof product with a trapezoid formed top and bottom skin
<b>DeltaTrimCorro™</b>	A registered name for Delta Panels™ insulated roof product with a corrugated formed top and a trapezoid formed bottom skin
<b>Insulated Roofing</b>	Covers all the products listed in DeltaSpan™
<b>DualCore™</b>	A registered name for Delta Panels™ insulated roof comprising of Expanded Polystyrene - Fire Retardant grade (EPS-FR) with a Mineral Wool (MW) core end of at least 900mm
<b>EPS-FR</b>	Expanded Polystyrene with a fire retardant additive, used as an insulating core in insulated roofing
<b>TPC</b>	Thermal Phenolic Composite core which has high fire ratings used in insulated roofing
<b>MW</b>	Mineral Wool is a noncombustible core with very high fire ratings used in insulated roofing
<b>Single Span</b>	The distance between two fixing supports
<b>Multi Span</b>	A continuous length that spans over three (3) or more fixing supports
<b>Roof Span</b>	Being the total span of the roof area with any overhang included
<b>Panel Span</b>	The length that the roof sheet can span between fixing supports
<b>End Overhang</b>	The length that the roof sheeting overhangs the last fixing support, forming a cantilevered portion. Refer to pages 22-33 for full spanning details
<b>Side Overhang</b>	DeltaSpan™ thicker than 50mm are capable of 400mm side overhang in any wind and location category and roof configuration, provided the panels are 1000mm in width at the side location on that particular roof

## GLOSSARY

<b>Cp,n</b>	Net pressure coefficient acting normal to the surface for canopies, freestanding roofs, walls, and the like (as defined in AS/NZS 1170.2:2021)
<b>Roof Slope</b>	The angle of the roof from its peak to its lowest point
<b>Cyclonic Region</b>	refer to Step 1 Wind Speed Determination
<b>NonTrafficable</b>	Not designed for direct foot traffic and requires a temporary walkway for maintenance access.
<b>NonCyclonic Region</b>	Refer to Step 1 Wind Speed Determination
<b>Beam Load Widths</b>	Is the (uplift) load on the beam. For simple awnings it is 50% of the roof sheeting span plus the overhang
<b>Uplift Loads on the Beam</b>	Is determined by a combination of the following factors, Beam Load Width, Awning Style and the Wind Category
<b>Post Load Widths</b>	The width of roof which is considered to act in loading the post. For simple awnings this is 50% of the roof sheeting plus any adjacent overhang that loads the beams connecting to the post
<b>Uplift Loads on the Post</b>	Is a force that consists of a combination of uplift force on the beam and the load width of the post
<b>Hold Down Capacity</b>	The maximum uplift capacity that the foundation can resist
<b>SHS Post</b>	Is a commonly used term for a Square Hollow Section steel post
<b>DeltaXtremeBeam™</b>	A two (2) piece roll-formed beam (RFB) designed for larger spanning
<b>DeltaBeam™</b>	Refers to either a two (2) piece roll-formed Steel Beam (RFB) or an extruded Aluminium Beam
<b>Receiver Channel</b>	A roll formed channel that is attached to an existing structure into which the roofing sheet is then fixed
<b>Flyover Bracket</b>	Brackets attached to an existing structure that a beam is then attached to create a fixing point for the roof sheeting. These can be either on the form of a Flyover Extenda Bracket or SHS uprights
<b>KingPost Gable</b>	A gable system utilizing a centre supporting King Post
<b>Portal Gable</b>	A rigid structural frame consisting essentially of two uprights connected at the top by a third member.

# ENGINEERING TABLE OF CONTENTS

## INDEX - MODULE A

### MODULE A - AWNINGS, PATIOS & CARPORTS

<b>Step 1 - Determining Correct Wind Speed</b> .....	<b>Page 10-15</b>
<b>Step 2 - Determine the Awning Types</b> .....	<b>Page 16-19</b>
<b>Step 3 - Select the Style of Roof Sheeting</b> .....	<b>Page 20-39</b>
3.1 Single Skin - Spans	
3.2 Insulated Spans	
- DeltaTrim™ Single-Span Non Cyclonic	
- DeltaTrim™ Multi-Span Non Cyclonic	
- DeltaTrim™ Cyclonic	
- DeltaOrb™ Single-Span Non Cyclonic	
- DeltaOrb™ Multi-Span Non Cyclonic	
- DeltaOrb™ Cyclonic	
- DeltaCorroCorro™ Single-Span Non Cyclonic	
- DeltaCorroCorro™ Multi-Span Non Cyclonic	
- DeltaCorroCorro™ Cyclonic	
- DeltaTrimTrim™ Single-Span Non Cyclonic	
- DeltaTrimTrim™ Multi-Span Non Cyclonic	
- DeltaTrimTrim™ Cyclonic	
- DeltaTrimCorro™ Single-Span Non Cyclonic	
- DeltaTrimCorro™ Multi-Span Non Cyclonic	
- DeltaTrimCorro™ Cyclonic	
3.3 DeltaDualCore™	
<b>Step 4 - Determine the Roof Load Width (RLW) of the Beam</b> .....	<b>Page 40</b>
<b>Step 5 - Beam Span Selection</b> .....	<b>Page 41-49</b>
<b>Step 6 - Calculate the Uplift on the Posts</b> .....	<b>Page 50-52</b>
<b>Step 7 - Post to Footing Selection</b> .....	<b>Page 53-59</b>
<b>Step 8 - Select Beam to Post Connection Type</b> .....	<b>Page 60-68</b>
<b>Step 9 - Connections to the House</b> .....	<b>Page 69-80</b>
- Metal Fascia	
- Timber Facia	
- Blockwork Wall	
- Masonary Wall	
- Flyover with Extenda Bracket	
- Flyover with Delta Extension Bracket	
- Flyover with SHS Upright	
- Beam to Timber Fascia Connection	
- Beam to Steel Fascia Connection	
- Beam to Beam Joiner	
- Beam to Beam Connection	
<b>Step 10 - Beam to Beam Connection Details</b> .....	<b>Page 81-84</b>
- Steel Beam to Beam Joiner	
- Steel Beam to Beam Connection	
- Aluminium Beam to Beam Joiner	
- Aluminium Beam to Beam Connection	
<b>Step 11 - Fixing Information</b> .....	<b>Page 85-87</b>

# LIST OF FIGURES

## MODULE A - AWNINGS, PATIOS & CARPORTS

A1	-	Roof Roof Dimension Front View .....	Page 19
A2	-	Roof Dimension Side View .....	Page 19
A3	-	Sheeting Profile - DeltaSingle™ .....	Page 20
A4	-	Sheeting Profile Drawings .....	Page 21
A5	-	Sheeting Profile Drawings .....	Page 28
A6	-	DeltaDualCore™ .....	Page 38
A7	-	Panel Layout Drawing .....	Page 38
A8	-	Determine the Roof Load Width (RLW) on the Beam for Single-Span ..	Page 40
A9	-	Determine the Roof Load Width (RLW) on the Beam for Multi-Span ....	Page 40
A10	-	Beam Types Steel .....	Page 41
A11	-	Beam Types Aluminium .....	Page 47
A12	-	Uplift Load Width on Post for Single-Span .....	Page 50
A13	-	Uplift Load Width on Post for Multi-Span .....	Page 50
A14	-	Timber Post to Stirrup .....	Page 53
A15	-	Steel Post to Pad Footing with Slab Over .....	Page 54
A16	-	Steel Post to Pad Footing .....	Page 55
A17	-	Column to Slab - Cross Bolt .....	Page 56
A18	-	Column to Slab - Tek Screws .....	Page 57
A19	-	Column to Slab - 2 Hole Base Plate .....	Page 58
A20	-	Column to Slab - 4 Hole Base Plate .....	Page 59
A21	-	Timber Post to Timber Beam .....	Page 60
A22	-	Timber Post to Delta™ Steel or Aluminium Beam .....	Page 61
A23	-	Delta™ Steel or Aluminium Beam to Post .....	Page 62
A24	-	Delta™ Steel or Aluminium Beam to Post .....	Page 63
A25	-	Delta™ Steel or Aluminium Beam to Post .....	Page 64
A26	-	Delta™ Steel or Aluminium Beam to Post .....	Page 65
A27	-	Delta™ Steel or Aluminium Beam to Post .....	Page 66
A28	-	Delta™ Steel or Aluminium Beam to Post .....	Page 67
A29	-	Delta™ Steel or Aluminium Beam to Post .....	Page 68
A30	-	Connection to House - Timber Fascia .....	Page 69
A31	-	Connection to the House - Metal Fascia .....	Page 70
A32	-	Connection to the House - Timber Fascia with Bugle Head Screw .....	Page 71
A33	-	Connection to the House - Masonry Wall .....	Page 72
A34	-	Connection to the House - Blockwork Wall .....	Page 73
A35	-	Connection to the House - Extenda Bracket .....	Page 74
A36	-	Connection to the House - Delta Extension Bracket .....	Page 75
A37	-	Connection to the House - SHS Upright .....	Page 76
A38	-	Beam to Timber Fascia Connection .....	Page 77
A39	-	Beam to Steel Fascia Connection.....	Page 78
A40	-	Through Fascia Beam .....	Page 79
A41	-	Adjustable Fascia Bracket .....	Page 80
A42	-	Steel Inline Beam Joiner .....	Page 81
A43	-	Steel Post End Cap Connection .....	Page 81
A44	-	Steel Post End Cap Connection .....	Page 81
A45	-	Steel Beam to Beam Connection .....	Page 82
A46	-	Aluminium Post End Cap Connection .....	Page 83
A47	-	Aluminium Beam to Beam Connection .....	Page 84
A48	-	Metal Tek Fixing in to Steel Beam .....	Page 86
A49	-	T17 Fixing in to Timber Beam .....	Page 86
A50	-	Secondary Fastener - Tek M13 x 25 .....	Page 86
A51	-	Secondary Fastener - Tek M10 x 16 .....	Page 86
A52	-	Dome Rivet 73 AS 4.3 .....	Page 86

## MODULE A - AWNINGS, PATIOS & CARPORTS



**ATTACHED  
CARPORT/STORAGE**



**ATTACHED FLYOVER**

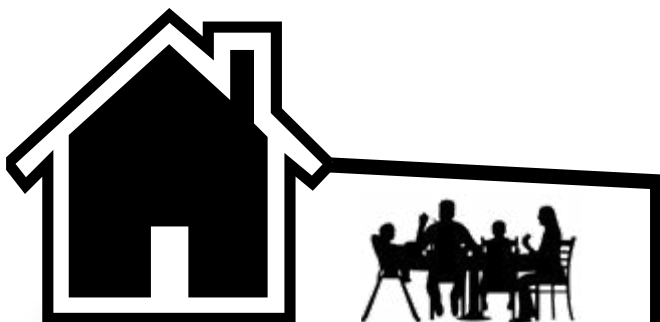

**ATTACHED PATIO**



## MODULE A - AWNINGS, PATIOS & CARPORTS ENGINEERING WORKSHEET

Single Span / Multi Span  
(cross out Not Applicable)

Wind Category: \_\_\_\_\_

Patio Type Selected: \_\_\_\_\_

Panel Thickness: \_\_\_\_\_

Roof Load With (RLW) on the Beam: \_\_\_\_\_

Beam Type: \_\_\_\_\_

Max Beam Span (between posts): \_\_\_\_\_

Load Width (outer posts): \_\_\_\_\_

Load Width (inner posts): \_\_\_\_\_

Uplift on Post (outer): \_\_\_\_\_ kN

Uplift on Post (inner): \_\_\_\_\_ kN

Bolt Size Selected: \_\_\_\_\_

Post to Beam Connection: style \_\_\_\_\_

Post to Footing Type: style \_\_\_\_\_

Connection to House Type : style \_\_\_\_\_

Fixing Details Required \_\_\_\_\_

## STEP 1

## DETERMINING CORRECT WIND SPEED

Whether you are building a stand-alone Carport or adding a Patio extension to your home, determining the correct wind rating is essential when considering the construction design and the materials that will be used.

There are 4 different factors that influence the wind classification, they are:-

- Region
- Terrain Category
- Shielding Determination
- Topographic Effect



Please remember that this is a guide only, check with your local authority to determine your exact rating.

For a detailed analysis refer to the Australian Standard AS/NZS 1170.2:2021, the approach described here follows the AS 4055:2021 - Residential wind code method.

This approach is only suitable for structures up to 2 storeys high and no wider than 16m and 8.5m high. Outside these limitations, we recommend that you engage a structural engineer to provide advice on the approach suitable to your situation.

### Step 1.1 - Region

### Select the Region

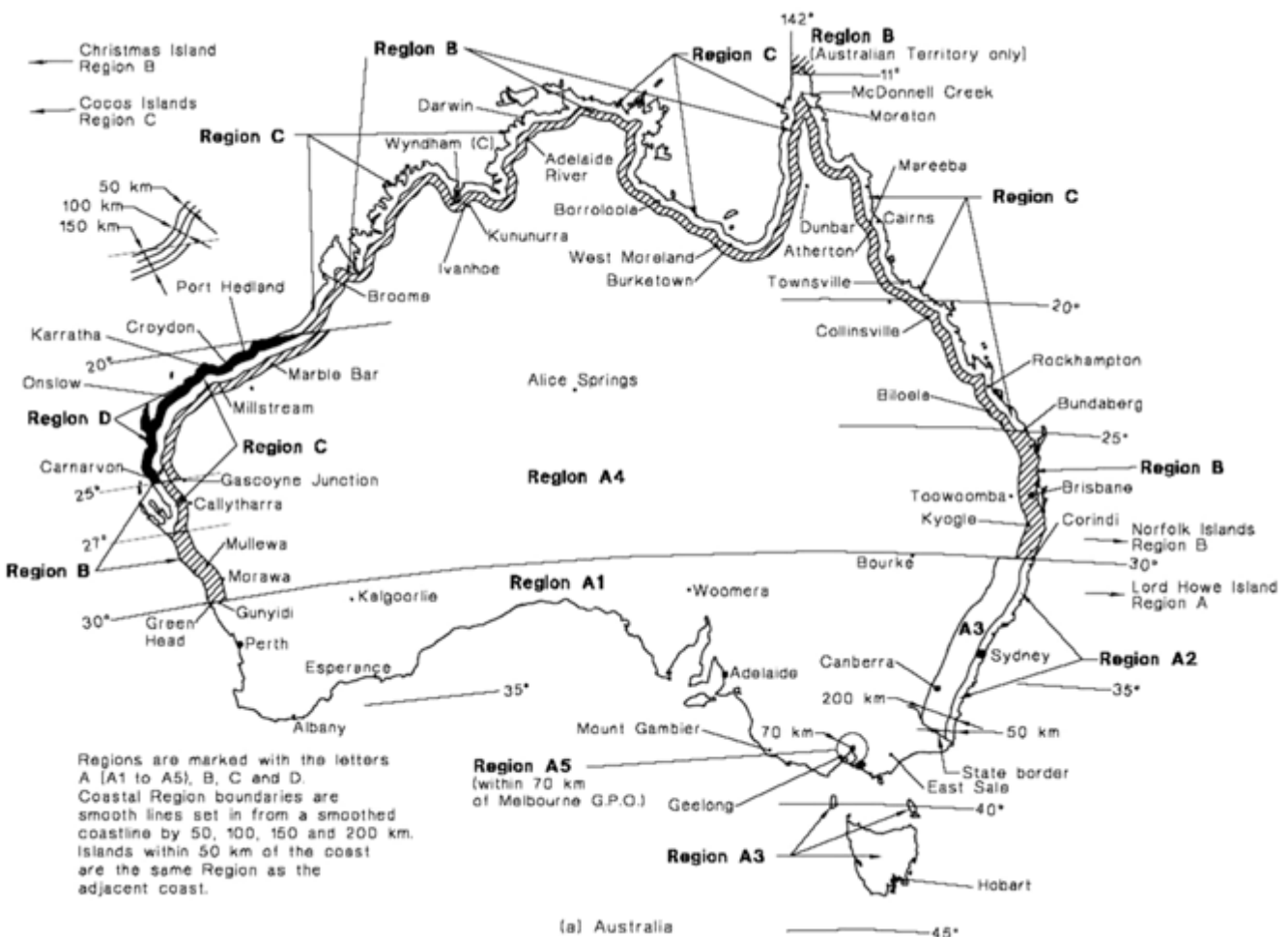

**Terrain Category**

**1:**

Exposed terrain for a 10km radius, no trees, other buildings or hills. No limited sized water ways such as, rivers, canals, lakes and enclosed bays.



**Terrain Category**

**1.5:**

Located adjacent to shoaling waves from open water ways such as, rivers, canals, lakes and large unenclosed bays on seas and oceans, extending greater than 10km in any wind direction.



**Terrain Category**

**2:**

Open terrain with few trees, surrounding buildings such as surrounding buildings such as farmland and cleared subdivisions with trees and uncut grass.



**Terrain Category**

**2.5:**

Open terrain, typical of a newly developed outer suburb housing estate, with few established trees or surrounding buildings.



**Terrain Category**

**3:**

A suburban backyard environment with numerous closely spaced houses. The minimum density of houses and trees (except in region C & D) shall be the equivalent to 10 house size obstructions per hectare. Where substantial well-established trees shall be considered as obstructions (except in region C & D).



# STEP 1 DETERMINING CORRECT WIND SPEED

## Step 1.3 Shielding Determination

The shielding effect of established trees and established building structures will have an effect on the upward wind pressures. With the exception of regions C & D where trees are not considered a shielding element.

The 3 shielding classifications are:-

### Full Shielding FS

At least 2 rows of housing or similar size permanent structures surround the intended construction site. In Regions A & B, heavily timbered areas provide full shielding as long as they are within 100 metres.

Full shielding is only possible for houses within Topographical Classes T0, T1 and T2. The Full Shielding classification is only applicable to suburban developments with 10 or more houses and or similar sized structures, per hectare. The effects of roads or other open spaces within a distance of 100 metres in any direction are exempt.



### Partial Shielding PS

Partial shielding is only possible for houses within Topographical Classes T0, T1, T2 and T3.

To qualify there is a requirement to have at least 2.5 houses per hectare or equivalent structures situated upwind of the intended building location. This is typical of an acreage estate or housing based at the 2nd row from open water, abutting parklands or airfields.



### No Shielding NS

This would be houses located on the edge of housing estates, the side of open water, airports, sporting fields and large open parklands.

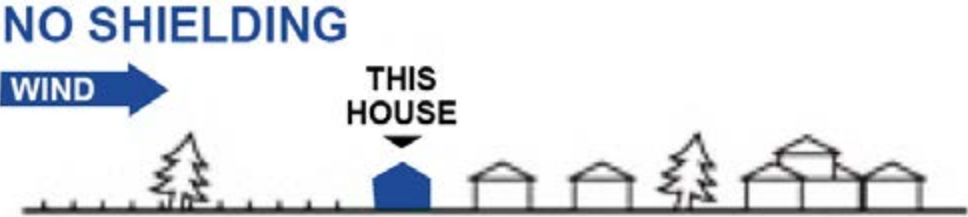

# STEP 1

# DETERMINING CORRECT WIND SPEED

## Step 1.4

## Topographic Effect

This step measures the effect of wind on a proposed structure based on its site location on a slope, ridge, mountain or escarpment, then the actual height/slope of that particular location. Topographic classifications are divided into zones T0, T1, T2, T3, T4 and T5. Use the following table to determine the applicable topographic classification of a proposed structure. If the slope, ridge, mountain or escarpment exceeds 30 metres please refer to AS 4055:2021.

### TOPOGRAPHIC CLASSIFICATION EFFECT

SITE LOCATION ON SLOPE / MOUNTAIN / RIDGE / ESCARPMENT



MAXIMUM SLOPE OF MOUNTAIN / RIDGE / ESCARPMENT	LOWER THIRD		TOP THIRD			OVER TOP
	LOWER THIRD	MID THIRD	LOWER THIRD	MID THIRD	UPPER THIRD	OVER TOP
Less than 1:20 (2.9°)	T0	T0	T0	T0	T0	T0
Greater than & equal to 1:20 to Less than 1:10 (≥ 2.9° to < 5.7°)	T0	T0	T1	T1	T1	T0
Greater than & equal to 1:10 to Less than 1:7.5 (≥ 5.7° to < 7.6°)	T0	T1	T1	T2	T2	T0
Greater than & equal to 1:7.5 to Less than 1:5 (≥ 7.6° to < 11.3°)	T0	T1	T2	T2	T3	T1
Greater than & equal to 1:5 to Less than 1:3 (≥ 11.3° to < 18.4°)	T0	T2	T2	T3	T4	T2
Greater than & equal to 1:3 (18.4°)	T0	T2	T3	T4	T5	T3

# STEP 1

# DETERMINING CORRECT WIND SPEED

## Step 1.5

## Topographic Classification

By applying the results of the above 4 different factors that influence the wind classification, Region, Terrain Category, Shielding Determination & Topographic Effect to the WIND CLASSIFICATION CHART below a determination on the topographical classification can be made and then applied to the Delta Panels Engineering Charts.

### WIND CLASSIFICATION FROM WIND REGION AND SITE CONDITIONS

#### TOPOGRAPHIC CLASSIFICATION

Region	Terrain Category	T0			T1			T2			T3		T4	T5
		FS	PS	NS	FS	PS	NS	FS	PS	NS	PS	NS	NS	NS
A	3	N1	N1	N1	N1	N2	N2	N2	N2	N2	N3	N3	N3	N4
	2.5	N1	N1	N2	N1	N2	N2	N2	N3	N3	N3	N3	N4	N4
	2	N1	N2	N2	N2	N2	N3	N2	N3	N3	N3	N3	N4	N4
	1.5	N2	N2	N2	N2	N3	N3	N3	N3	N3	N3	N4	N4	N5
	1	N2	N3	N3	N2	N3	N3	N3	N3	N4	N4	N4	N4	N5
B	3	N2	N2	N3	N2	N3	N3	N3	N3	N4	N4	N4	N4	N5
	2.5	N2	N3	N3	N3	N3	N3	N3	N4	N4	N4	N4	N5	N5
	2	N2	N3	N3	N3	N3	N4	N3	N4	N4	N4	N5	N5	N6
	1.5	N3	N3	N4	N3	N4	N4	N4	N4	N4	N5	N5	N5	N6
	1	N3	N4	N4	N4	N4	N4	N4	N5	N5	N5	N5	N6	N6
C	3	C1	C1	C2	C1	C2	C2	C2	C2	C3	C3	C3	C3	C4
	2.5	C1	C2	C2	C2	C2	C2	C2	C3	C3	C3	C3	C4	N/A
	2	C1	C2	C2	C2	C2	C3	C2	C3	C3	C3	C4	C4	N/A
	1.5	C2	C2	C3	C2	C3	C3	C3	C3	C4	C4	C4	N/A	N/A
	1	C2	C3	C3	C3	C3	C3	C3	C4	C4	C4	N/A	N/A	N/A
D	3	C2	C3	C3	C2	C3	C3	C3	C3	C4	C4	C4	N/A	N/A
	2.5	C2	C3	C3	C3	C3	C4	C3	C4	C4	C4	N/A	N/A	N/A
	2	C3	C3	C4	C3	C4	C4	C4	C4	N/A	N/A	N/A	N/A	N/A
	1.5	C3	C4	C4	C4	C4	N/A	C4	N/A	N/A	N/A	N/A	N/A	N/A
	1	C3	C4	C4	C4	N/A	N/A	N/A	N/A	N/A	N/A	N/A	N/A	N/A

**WIND CLASSIFICATION CONVERSION TABLE**

WIND CLASSIFICATION		Serviceability Limit State Gust Wind Speed metres per second	Ultimate Limit State Gust Wind Speed metres per second
Regions A and B	Regions C and D		
<b>N1 (Non-Cyclonic)</b>	N/A	W26	W34
<b>N2 (Non-Cyclonic)</b>	N/A	W26	W40
<b>N3 (Non-Cyclonic)</b>	C1 (Cyclonic)	W32	W50
<b>N4 (Non-Cyclonic)</b>	C2 (Cyclonic)	W39	W61
<b>N5 (Non-Cyclonic)</b>	C3 (Cyclonic)	W47	W74
<b>N6 (Non-Cyclonic)</b>	C4 (Cyclonic)	W55	W86

**Please Note:**

This is to be used as a guide only. Check with your local authority for your exact rating. For a complete analysis of estimating please refer to Australian Standard AS/NZS 1170.2:2021 and AS 4055:2021

Delta Panels will not accept any liability for any loss or damage suffered as a result of any errors in the misinterpretation of any information provided in this guide. It is recommended to seek the services of an independent registered Engineer to confirm any calculations.



**TYPE 0**

Free-Standing  
(Cp,n +0.5/0.7)

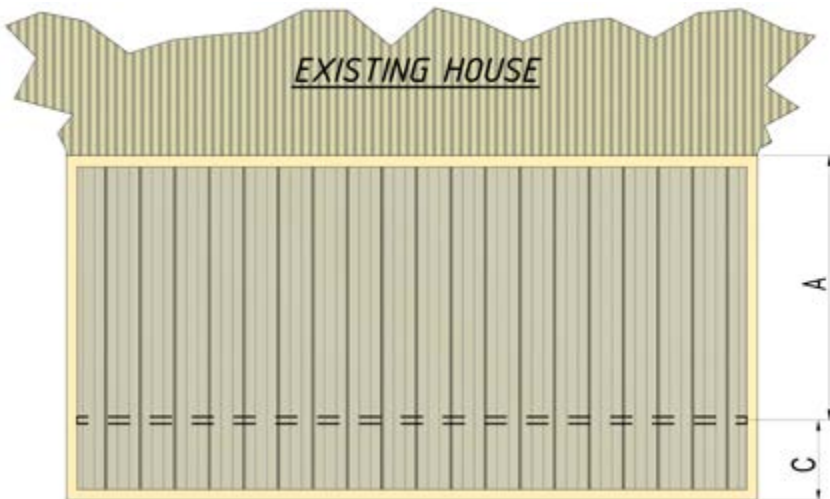

**TYPE 1/P**

One Side Attached  
(Cp,n +0.7/0.5)

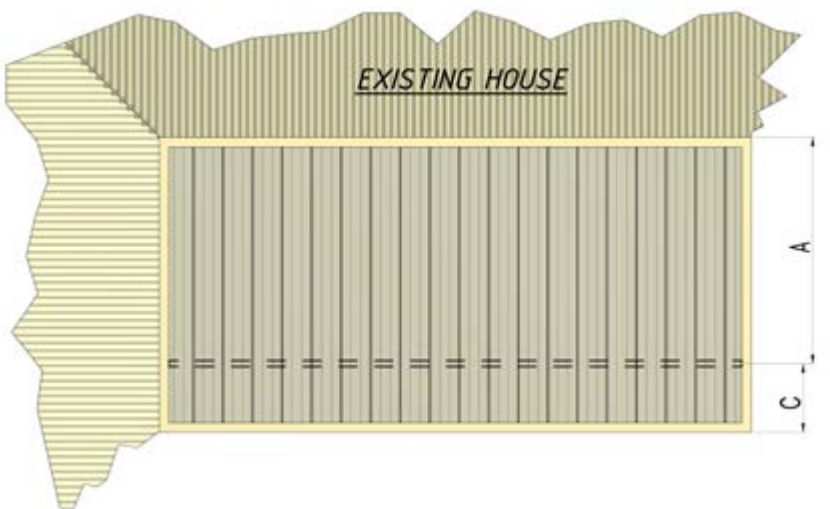

**TYPE 2**

Two Side Attached  
(Cp,n +1)



**STEP 2****SELECT THE PATIO TYPE****TYPE 3**

Three Side Attached  
( $C_{p,n} + 1.2$ )

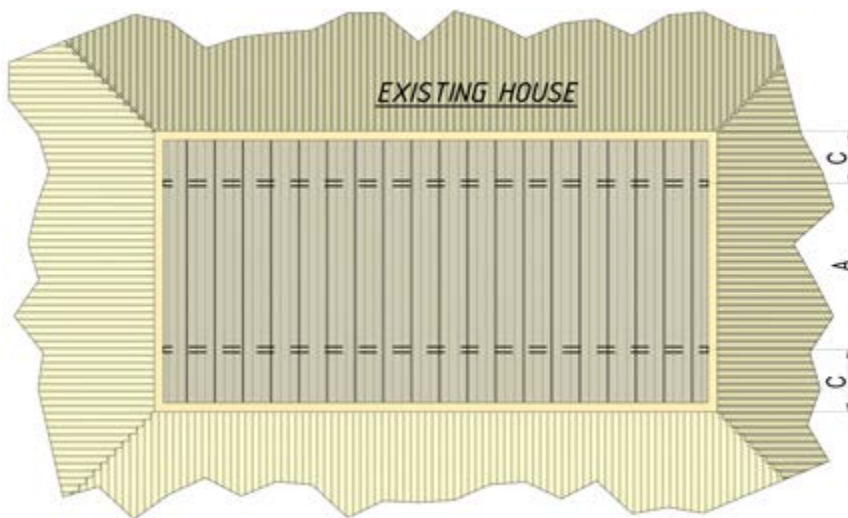
**TYPE 4**

All Sides Attached  
( $C_{p,n} + 1$ )

**Notes:**

1. A side wall is classed as closed in if 70% of the cross sectional area is covered.
2. "A" above = DeltaSpan™ Panel Span (refer to Step 2).
3. "C" above = DeltaSpan™ Overhang.

**Minimum Pitch:**

- > **DeltaTrim™** 2°
- > **DeltaOrb™** 3°
- > **DeltaCorroCorro™** 3°
- > **DeltaTrimTrim™** 2°
- > **DeltaTrimCorro™** 3°

**Defintion of Type 1P Awning**

The engineering must allow for all conditions of usages, therefore a standard awning could be used for a carport or patio.

In the case of a carport it is possible to have one side blocked more than considered an open side by a car, caravan, camper van, boat etc and so for general awnings/carports the given wind pressure should be used and a type 1 should be considered.

In the case where the awning is usually at the rear of the property where it cannot be accessed by large vehicles that could block off one side the wind pressures experienced would be lower so a type 1P is allowed for in this situation.

It should be noted that any building in or blocking of the 3 open sides could be considered to require the use of the type 1 engineering.

Typically a type 1 would be used for a garage, and type 1P would be considered for a backyard lifestyle awning (providing the requirements are followed for this type).

**Limits for Using Type 1P Awning Classification**

Following are the dimensional requirements for using Type 1 awning classification, which has 1 partial wall.

- For awning dimensions, refer to figure 1.
- Awning is to be attached one side only to an existing building.
- Awning pitch “α” is to be between 1° and 10°.
- Slope of the awning is to be normal to the attached wall.
- Minimum  $hc = 0.05 \times d$
- Maximum  $hc = 1.0 \times d$
- Maximum  $hc/wc$  to be as per Table 1.
- Maximum blockage under the roof parallel to the attached wall is to be 56% of the projected area.
- Awnings attached one side that do not comply with the above are to be classified as Type 1.

Table 1 Dimensional limits for $C_{p,n}=0.5$			
hc/h	Max. hc/wc	hc/h	Max. hc/wc
<0.4	Not Allowed	0.75 to 0.8	0.71
0.4 to 0.5	No limits	0.8 to 0.9	0.45
0.5 to 0.75	1.0	0.9 to 1.0	0.33

**STEP 2**

**SELECT THE PATIO TYPE**

**Figure A1 & A2 - Roof Dimension**



**FRONT VIEW**

Figure A1

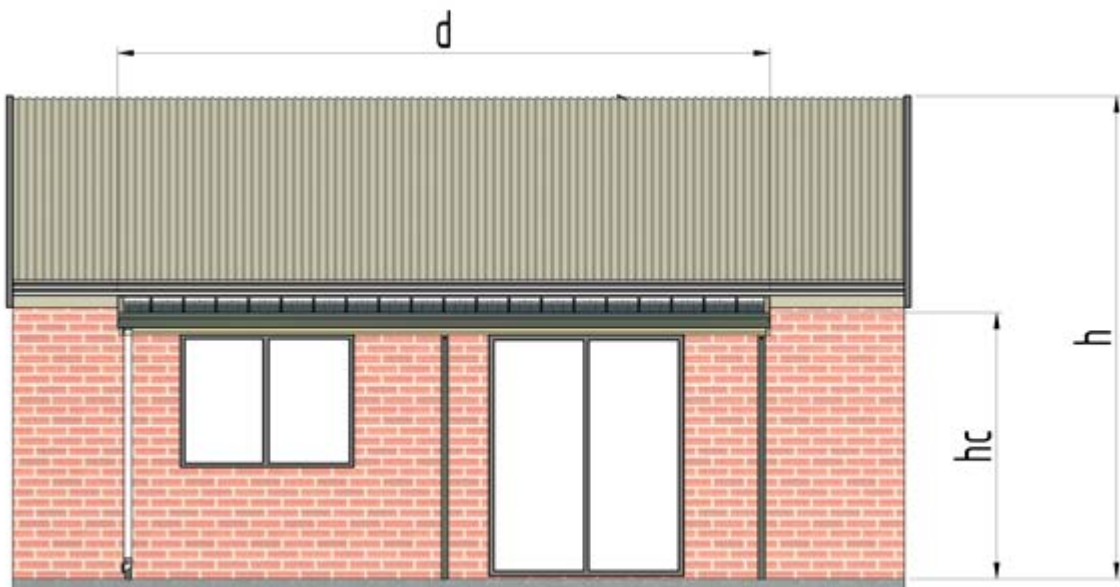

**SIDE VIEW**

Figure A2

## STEP 3

## SELECT THE STYLE OF ROOF SHEETING

### Step 3.1 Single Skin - Spans



#### DeltaSingle™

1. Minimum roofing slope to be 1°.
2. The minimum fixing requirements are 3/14g screws with cyclonic washers per sheet per support.
3. Allowable deflection limit for wind loading is span / 50.
4. Maintenance load of 0.5kN has been allowed for.
5. DeltaSingle™ is classified as a non-trafficable roof.
6. Maximum allowable overhang of sheeting is 30% of the adjacent span or 900mm, whichever is lesser.
7. 'Roof Span' is the maximum spacing of supports for sheeting.

#### Figure 2 - Sheeting Profile

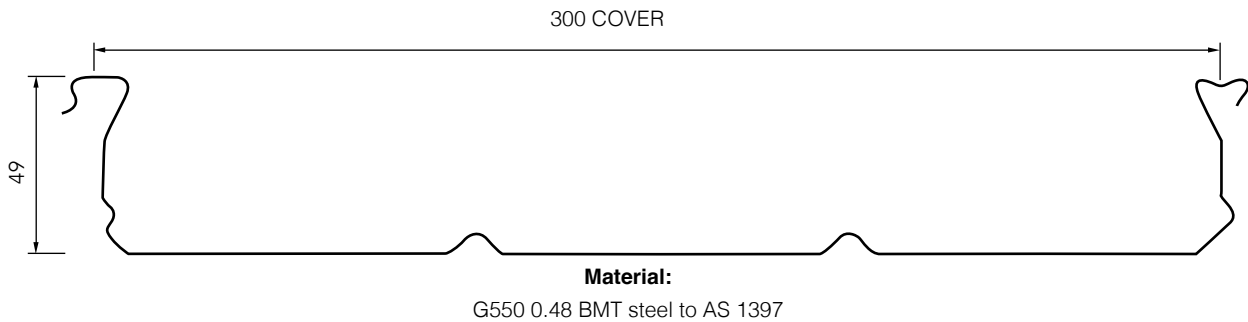

Figure A3

#### ALLOWABLE SPAN (MM) FOR 0.48 BMT DELTA SHEETING IN NON-CYCLONIC REGIONS

Wind Class	Single-Span				Multi-Span			
	Cp,n				Cp,n			
	0.5	0.7	1	1.2	0.5	0.7	1	1.2
Patio Type	1P	1	2+4	3	1P	1	2+4	3
N1	5340	5130	4550	4280	6330	5820	4820	4370
N2	5240	4910	4060	3650	5850	4900	4050	3650
N3	4630	3850	3130	2820	4620	3850	3130	2820
N4	3720	3060	2500	2250	3710	3060	2490	2250
N5	2970	2460	2010	1830	2970	2450	2010	1830

## STEP 3

## SELECT THE STYLE OF ROOF SHEETING

### Step 3.2

### Insulated Spans

#### DeltaTrim™

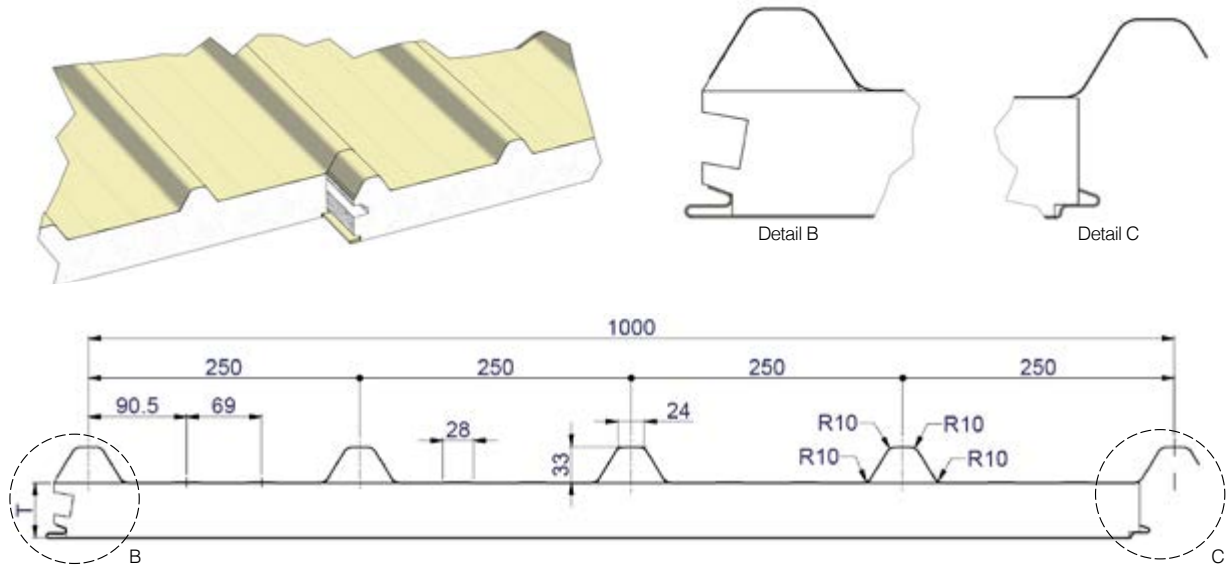

#### DeltaOrb™

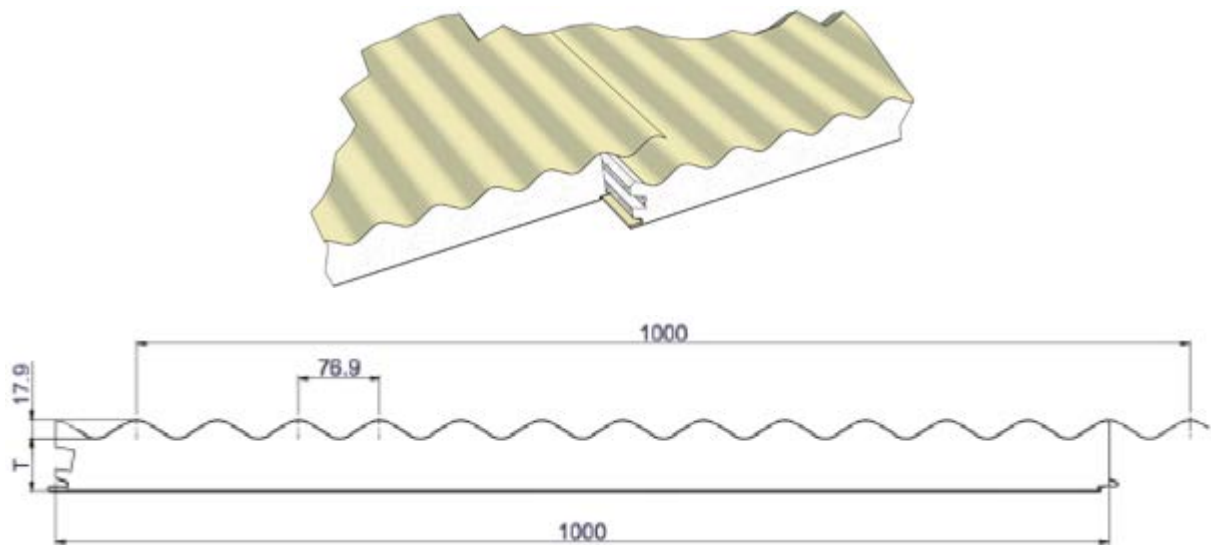

<b>Steel Skin Details</b>	Top Skin	0.42mm / G550 AZ150
	Bottom Skin	0.60mm / G300 Z275
<b>Core Material Options</b>	<ul style="list-style-type: none"> <li>- SL Grade Polystyrene - Fire Retardant Grade</li> <li>- Thermosetting Phenolic Composite - TPC</li> <li>- Mineral Wool - MW</li> </ul>	

Figure A4

# STEP 3

# SELECT THE STYLE OF ROOF SHEETING

## Step 3.2

## Insulated Spans



SINGLE-SPAN NON-CYCLONIC SPAN TABLE

Wind Category	Panel Thickness	TYPE 1	TYPE 2	TYPE 3	TYPE 4	Maximum Overhang
		(3 or more sides open)	(2 sides open)	(1 side open)	(Fully enclosed)	(Each end)
N1/N2 (W28 /W33)	50mm	5400	5000	4500	4300	900
	75mm	6500	5500	5000	4700	900
	100mm	7200	6200	5700	5500	1000
	125mm	7800	6800	6400	6800	1200
	150mm	8200	7400	7000	6800	1200
	175mm	8600	8000	7500	7000	1200
	200mm	9000	8600	8000	7200	1200
N3 (W41)	50mm	4800	3800	3300	3000	900
	75mm	5500	4300	3900	3700	900
	100mm	6200	5000	4500	4300	1000
	125mm	6800	5500	5000	5000	1200
	150mm	7400	6000	5500	5100	1200
	175mm	8000	7500	6000	5900	1200
	200mm	8600	8000	6500	6300	1200
N4 (W50)	50mm	4000	3300	3000	3000	600
	75mm	4600	3600	3400	3300	600
	100mm	5300	4100	3800	3500	800
	125mm	6000	4500	4200	4000	900
	150mm	6600	5200	4800	4600	900
	175mm	7000	5800	5200	5000	900
	200mm	7400	6400	5600	5400	900
N5 (W60)	50mm	3300	2800	2400	2200	600
	75mm	3600	3000	2800	2500	600
	100mm	3900	3300	3100	3000	600
	125mm	4100	3800	3500	3300	600
	150mm	4500	4300	3900	3500	600
	175mm	5000	4700	4400	4200	600
	200mm	5500	5100	4800	4600	600

### STEP 3

### SELECT THE STYLE OF ROOF SHEETING

#### Step 3.2

#### Insulated Spans



MULTI-SPAN NON-CYCLONIC SPAN TABLE

Wind Category	Panel Thickness	TYPE 1	TYPE 2	TYPE 3	TYPE 4	Maximum Overhang
		(3 or more sides open)	(2 sides open)	(1 side open)	(Fully enclosed)	(Each end)
N1/N2 (W28 /W33)	50mm	5900	5500	4950	4730	900
	75mm	7000	6000	5500	5170	900
	100mm	7700	6700	6200	6000	1000
	125mm	8300	7300	6900	7300	1200
	150mm	8700	7900	7500	7300	1200
	175mm	9100	8500	8000	7500	1200
	200mm	9400	8800	8300	7800	1200
N3 (W41)	50mm	5280	4180	3630	3300	900
	75mm	6000	4730	4290	4070	900
	100mm	6700	5500	4950	4730	1000
	125mm	7300	6000	5500	5500	1200
	150mm	7900	6500	6000	5600	1200
	175mm	8500	8000	6500	6400	1200
	200mm	9100	8600	7100	6900	1200
N4 (W50)	50mm	4400	3630	3300	3300	600
	75mm	5060	3960	3740	3630	600
	100mm	5800	4510	4180	3850	800
	125mm	6500	4950	4620	4400	900
	150mm	7100	5700	5280	5060	900
	175mm	7500	6300	5700	5500	900
	200mm	7900	6800	6200	6000	900
N5 (W60)	50mm	3630	3080	2640	2420	600
	75mm	3960	3300	3080	2750	600
	100mm	4290	3630	3410	3300	600
	125mm	4510	4180	3850	3630	600
	150mm	4950	4730	4290	3850	600
	175mm	5500	5170	4840	4620	600
	200mm	6000	5650	5220	5050	600

**STEP 3****SELECT THE STYLE OF ROOF SHEETING****Step 3.2****Insulated Spans****CYCLONIC SPAN TABLE**

Wind Category	Panel Thickness	TYPE 1	TYPE 2	TYPE 3	TYPE 4	Maximum Overhang
		(3 or more sides open)	(2 sides open)	(1 side open)	(Fully enclosed)	(Each end)
C1 (W41C)	50mm	4800	3700	3100	3200	900
	75mm	5500	4500	3700	3700	900
	100mm	6000	5000	4400	4400	1000
	125mm	6500	5600	5000	4900	1200
	150mm	7000	6000	5500	5400	1200
	175mm	7500	6500	6000	6000	1200
	200mm	8000	7000	6500	6500	1200
C2 (W50C)	50mm	4000	2900	2600	2500	600
	75mm	4600	3500	3000	3000	600
	100mm	5200	4200	3500	3400	600
	125mm	5700	4800	4000	3900	600
	150mm	6300	5300	4500	4400	600
	175mm	6700	6000	5000	4900	600
	200mm	7100	6300	5300	5200	600
C3 (W60C)	50mm	3300	2600	2200	2000	450
	75mm	3800	2800	2600	2400	450
	100mm	4300	3100	2800	2700	450
	125mm	4600	3500	3000	2900	450
	150mm	5500	3900	3400	3500	450
	175mm	5900	4300	3800	4000	450
	200mm	6300	4700	4200	4400	450



# STEP 3

# SELECT THE STYLE OF ROOF SHEETING

## Step 3.2

## Insulated Spans



SINGLE-SPAN NON-CYCLONIC SPAN TABLE

Wind Category	Panel Thickness	TYPE 1	TYPE 2	TYPE 3	TYPE 4	Maximum Overhang
		(3 or more sides open)	(2 sides open)	(1 side open)	(Fully enclosed)	(Each end)
N1/N2 (W28 /W33)	50mm	5400	4800	4300	4400	900
	75mm	6700	5700	5200	5300	900
	100mm	7400	6300	5900	6000	1000
	125mm	8000	6700	6200	6300	1200
	150mm	8500	7000	6500	6500	1200
	175mm	8800	8400	7900	7900	1200
	200mm	9200	9000	8500	8500	1200
N3 (W41)	50mm	5100	4000	3400	3600	900
	75mm	5700	4500	4100	4200	900
	100mm	6200	4900	4500	4600	1000
	125mm	6600	5400	5000	5100	1200
	150mm	6900	5500	5100	5200	1200
	175mm	7200	6000	5600	5500	1200
	200mm	7500	6500	5950	5800	1200
N4 (W50)	50mm	4000	3100	2600	2700	600
	75mm	4700	3700	3200	3300	600
	100mm	5100	4300	3600	3700	800
	125mm	5400	4700	4200	4300	900
	150mm	5600	4900	4300	4400	900
	175mm	5800	5100	4500	4600	900
	200mm	6200	5500	4900	5000	900
N5 (W60)	50mm	3400	2900	2400	2500	600
	75mm	3700	3100	2900	3000	600
	100mm	4100	3400	3100	3200	600
	125mm	4300	3600	3300	3400	600
	150mm	4500	3900	3500	3500	700
	175mm	4700	4100	3700	3700	700
	200mm	5000	4400	4000	4000	700

# STEP 3

# SELECT THE STYLE OF ROOF SHEETING

## Step 3.2

## Insulated Spans



MULTI-SPAN NON-CYCLONIC SPAN TABLE

Wind Category	Panel Thickness	TYPE 1	TYPE 2	TYPE 3	TYPE 4	Maximum Overhang
		(3 or more sides open)	(2 sides open)	(1 side open)	(Fully enclosed)	(Each end)
N1/N2 (W28 /W33)	50mm	5900	5280	4730	4840	900
	75mm	7200	6200	5700	5800	900
	100mm	7900	6800	6400	6500	1000
	125mm	8500	7200	6700	6800	1200
	150mm	9000	7500	7000	7000	1200
	175mm	9400	7900	7400	7400	1200
	200mm	9900	8200	7600	7600	1200
N3 (W41)	50mm	5600	4400	3740	3960	900
	75mm	6200	4950	4510	4620	900
	100mm	6700	5390	4950	5060	1000
	125mm	7100	5900	5500	5600	1200
	150mm	7400	6000	5600	5700	1200
	175mm	7700	6300	5800	5900	1200
	200mm	8000	6600	6100	6200	1200
N4 (W50)	50mm	4400	3410	2860	2970	600
	75mm	5170	4070	3520	3630	600
	100mm	5600	4730	3960	4070	800
	125mm	5900	5170	4620	4730	900
	150mm	6100	5390	4730	4840	900
	175mm	6300	5600	4950	5100	900
	200mm	6500	5800	5150	5200	900
N5 (W60)	50mm	3740	3190	2640	2750	600
	75mm	4070	3410	3190	3300	600
	100mm	4510	3740	3410	3520	600
	125mm	4730	3960	3630	3740	600
	150mm	4950	4290	3850	3850	700
	175mm	5180	4560	3960	3960	700
	200mm	5350	4890	4050	4050	700

## STEP 3

## SELECT THE STYLE OF ROOF SHEETING

### Step 3.2

### Insulated Spans



CYCLONIC SPAN TABLE

Wind Category	Panel Thickness	TYPE 1	TYPE 2	TYPE 3	TYPE 4	Maximum Overhang
		(3 or more sides open)	(2 sides open)	(1 side open)	(Fully enclosed)	(Each end)
C1 (W41C)	50mm	4500	3500	2900	3000	900
	75mm	5200	4000	3500	3600	900
	100mm	5700	4400	3900	4000	1000
	125mm	6100	4800	4200	4300	1200
	150mm	6400	5100	4500	4600	1200
	175mm	6700	5400	4800	4900	1200
	200mm	7000	5700	5100	5200	1200
C2 (W50C)	50mm	3700	2700	2300	2400	600
	75mm	4400	3300	2800	2900	600
	100mm	4600	3700	3100	3200	600
	125mm	4900	4200	3500	3600	600
	150mm	5100	4500	3800	3900	600
	175mm	5300	4700	4100	4150	600
	200mm	5500	5000	4400	4350	600
C3 (W60C)	50mm	3100	2400	2000	1900	450
	75mm	3300	2600	2400	2300	450
	100mm	3600	2900	2600	2500	450
	125mm	3900	3000	2800	2700	450
	150mm	4100	3100	3000	2900	450
	175mm	4300	3300	3200	3100	450
	200mm	4500	3500	3400	3300	450

**STEP 3** / SELECT THE STYLE OF ROOF SHEETING

Step 3.2 / Insulated Spans

**DeltaCorroCorro™**

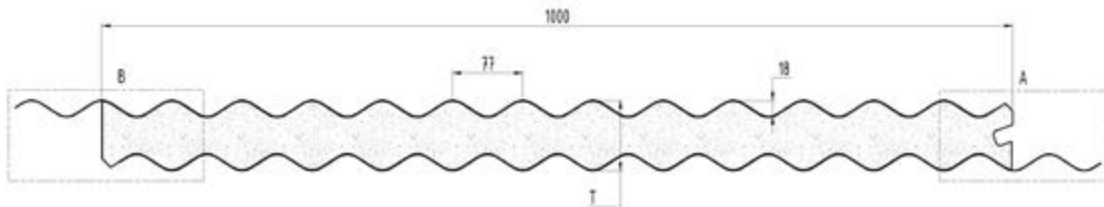
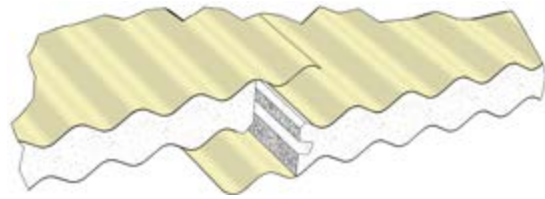

**DeltaTrimTrim™**

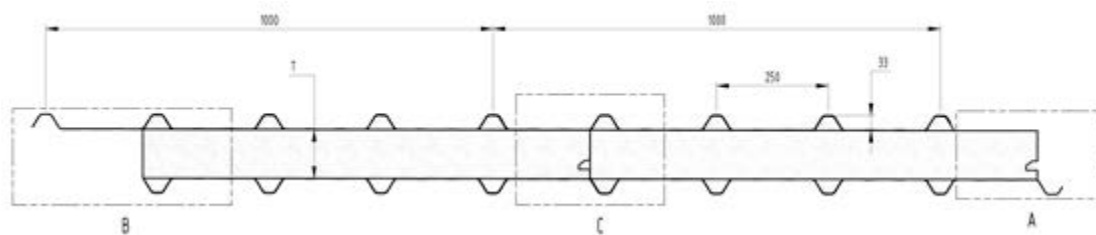
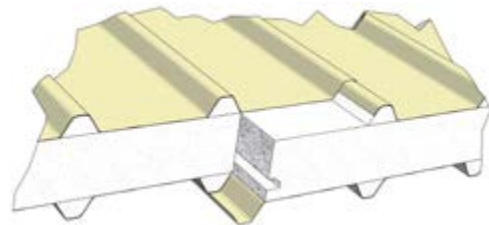

**DeltaTrimCorro™**

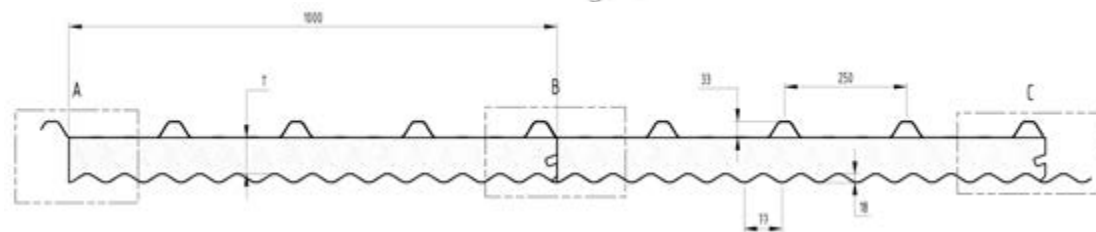
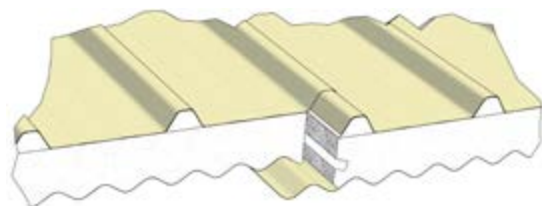

<b>Steel Skin Details</b>	Top Skin	0.42mm / G550 AZ150
	Bottom Skin	0.42mm / G550 AZ150

Figure A5

## STEP 3

## SELECT THE STYLE OF ROOF SHEETING

### Step 3.2

### Insulated Spans



SINGLE-SPAN NON-CYCLONIC SPAN TABLE

Wind Category	Panel Thickness	TYPE 1	TYPE 2	TYPE 3	TYPE 4	Maximum Overhang
		(3 or more sides open)	(2 sides open)	(1 side open)	(Fully enclosed)	(Each end)
N1/N2 (W28 /W33)	75mm	4900	4900	4900	4900	1700
	100mm	6300	6300	6300	6300	2200
	125mm	7600	7600	7600	7600	2600
	150mm	8200	8200	8200	8200	2900
	175mm	9600	9600	9600	9600	3300
	200mm	10600	10600	10600	10600	3700
	250mm	12000	12000	12000	12000	4200
N3 (W41)	75mm	4800	4400	4000	4000	1400
	100mm	6000	5600	5100	5100	1800
	125mm	7300	6700	6100	6100	2200
	150mm	8000	7300	6800	6800	2400
	175mm	9500	8700	8100	8100	2800
	200mm	10500	9700	8900	8900	3100
	250mm	12000	11500	10000	10000	3500
N4 (W50)	75mm	4000	3500	3200	3200	1000
	100mm	5000	4600	4200	4200	1300
	125mm	6000	5600	5000	5000	1500
	150mm	6600	6100	5500	5500	1700
	175mm	7900	7200	6700	6700	2000
	200mm	8800	8100	7400	7400	2200
	250mm	10500	9600	8400	8400	2300
N5 (W60)	75mm	3300	2600	2400	2400	600
	100mm	4200	3600	3300	3300	800
	125mm	5100	4600	4100	4100	1000
	150mm	5600	5100	4500	4500	1100
	175mm	6700	6100	5500	5500	1400
	200mm	7400	6800	6000	6000	1500
	250mm	8800	7600	6000	6000	1800

### STEP 3

## SELECT THE STYLE OF ROOF SHEETING

### Step 3.2

### Insulated Spans



MULTI-SPAN NON-CYCLONIC SPAN TABLE

Wind Category	Panel Thickness	TYPE 1	TYPE 2	TYPE 3	TYPE 4	Maximum Overhang
		(3 or more sides open)	(2 sides open)	(1 side open)	(Fully enclosed)	(Each end)
N1/N2 (W28 /W33)	75mm	5400	5400	5400	5400	1700
	100mm	7000	7000	7000	7000	2200
	125mm	8400	8400	8400	8400	2600
	150mm	9000	9000	9000	9000	2900
	175mm	10100	10100	10100	10100	3300
	200mm	11100	11100	11100	11100	3700
	250mm	12600	12600	12600	12600	4200
N3 (W41)	75mm	5300	4800	4400	4400	1400
	100mm	6600	6200	5600	5600	1800
	125mm	8000	7400	6700	6700	2200
	150mm	8800	8000	7500	7500	2400
	175mm	10000	9100	8500	8500	2800
	200mm	11000	10200	9300	9300	3100
	250mm	12600	12100	10500	10500	3500
N4 (W50)	75mm	4400	3900	3500	3500	1000
	100mm	5500	5100	4600	4600	1300
	125mm	6600	6200	5500	5500	1500
	150mm	7300	6700	6100	6100	1700
	175mm	8300	7600	7000	7000	2000
	200mm	9200	8500	7800	7800	2200
	250mm	11000	10100	8800	8800	2300
N5 (W60)	75mm	3300	2900	2600	2600	600
	100mm	4600	4000	3600	3600	800
	125mm	5600	5100	4500	4500	1000
	150mm	6200	5600	5000	5000	1100
	175mm	7000	6400	5800	5800	1400
	200mm	7800	7100	6300	6300	1500
	250mm	9200	8000	6300	6300	1800

# STEP 3

# SELECT THE STYLE OF ROOF SHEETING

## Step 3.2

## Insulated Spans



CYCLONIC SPAN TABLE

Wind Category	Panel Thickness	TYPE 1	TYPE 2	TYPE 3	TYPE 4	Maximum Overhang
		(3 or more sides open)	(2 sides open)	(1 side open)	(Fully enclosed)	(Each end)
C1 (W41C)	75mm	4900	4100	3500	3000	900
	100mm	6100	5600	5100	3900	1100
	125mm	7400	6800	6200	4500	1300
	150mm	8700	7900	7300	5100	1500
	175mm	9600	8800	8200	5700	1600
	200mm	10600	9800	9100	6200	1700
	250mm	12200	11700	10800	8300	1800
C2 (W50C)	75mm	3300	2900	2500	2100	600
	100mm	4800	4100	3500	3100	900
	125mm	6200	5500	4700	3700	1200
	150mm	7400	6700	6000	4200	1300
	175mm	8100	7400	6900	4700	1400
	200mm	9000	8300	7700	5200	1500
	250mm	10800	9900	9100	6800	1900
C3 (W60C)	75mm	2400	2100	1800	1600	400
	100mm	3400	3000	2600	2200	500
	125mm	4500	3900	3300	2900	700
	150mm	5900	5000	4300	3200	800
	175mm	6800	5700	4900	3600	900
	200mm	7600	6700	5700	4100	1000
	250mm	9100	7800	6500	4700	1200
C4 (W70C)	75mm	1900	1600	1500	1300	300
	100mm	2700	2300	2000	1700	400
	125mm	3500	2900	2500	2100	500
	150mm	4500	3800	3200	2400	600
	175mm	5100	4300	3700	2900	700
	200mm	5900	4900	4200	3300	770
	250mm	7100	5700	4700	3400	800

## STEP 3

## SELECT THE STYLE OF ROOF SHEETING

### Step 3.2

### Insulated Spans



SINGLE-SPAN NON-CYCLONIC SPAN TABLE

Wind Category	Panel Thickness	TYPE 1	TYPE 2	TYPE 3	TYPE 4	Maximum Overhang
		(3 or more sides open)	(2 sides open)	(1 side open)	(Fully enclosed)	(Each end)
N1/N2 (W28 /W33)	75mm	4900	4900	4900	4900	1700
	100mm	6300	6300	6300	6300	2200
	125mm	7600	7600	7600	7600	2600
	150mm	8200	8200	8200	8200	2900
	175mm	9600	9600	9600	9600	3300
	200mm	11100	11100	11100	11100	3700
N3 (W41)	75mm	4800	4400	4000	4000	1400
	100mm	6000	5600	5100	5100	1800
	125mm	7300	6700	6100	6100	2200
	150mm	8000	7300	6800	6800	2400
	175mm	9500	8700	8100	8100	2800
	200mm	11000	10200	9300	9300	3100
N4 (W50)	75mm	4000	3500	3200	3200	1000
	100mm	5000	4600	4200	4200	1300
	125mm	6000	5600	5000	5000	1500
	150mm	6600	6100	5500	5500	1700
	175mm	7900	7200	6700	6700	2000
	200mm	9200	8500	7800	7800	2200
N5 (W60)	75mm	3300	2600	2400	2400	600
	100mm	4200	3600	3300	3300	800
	125mm	5100	4600	4100	4100	1000
	150mm	5600	5100	4500	4500	1100
	175mm	6700	6100	5500	5500	1400
	200mm	7800	7100	6300	6300	1500



## STEP 3

## SELECT THE STYLE OF ROOF SHEETING

### Step 3.2

### Insulated Spans



MULTI-SPAN NON-CYCLONIC SPAN TABLE

Wind Category	Panel Thickness	TYPE 1	TYPE 2	TYPE 3	TYPE 4	Maximum Overhang
		(3 or more sides open)	(2 sides open)	(1 side open)	(Fully enclosed)	(Each end)
N1/N2 (W28 /W33)	75mm	5400	5400	5400	5400	1700
	100mm	7000	7000	7000	7000	2200
	125mm	8400	8400	8400	8400	2600
	150mm	9000	9000	9000	9000	2900
	175mm	9600	9600	9600	9600	3300
	200mm	10600	10600	10600	10600	3700
N3 (W41)	75mm	5300	4800	4400	4400	1400
	100mm	6600	6200	5600	5600	1800
	125mm	8000	7400	6700	6700	2200
	150mm	8800	8000	7500	7500	2400
	175mm	9500	8700	8100	8100	2800
	200mm	10500	9700	8900	8900	3100
N4 (W50)	75mm	4400	3900	3500	3500	1000
	100mm	5500	5100	4600	4600	1300
	125mm	6600	6200	5500	5500	1500
	150mm	7300	6700	6100	6100	1700
	175mm	7900	7200	6700	6700	2000
	200mm	8800	8100	7400	7400	2200
N5 (W60)	75mm	3300	2900	2600	2600	600
	100mm	4600	4000	3600	3600	800
	125mm	5600	5100	4500	4500	1000
	150mm	6200	5600	5000	5000	1100
	175mm	6700	6100	5500	5500	1400
	200mm	7400	6800	6000	6000	1500

## STEP 3

## SELECT THE STYLE OF ROOF SHEETING

### Step 3.2

### Insulated Spans

**> DeltaTrimTrim™-EPS-FR**  
**> DeltaTrimTrim™-TPC**

CYCLONIC SPAN TABLE

Wind Category	Panel Thickness	TYPE 1	TYPE 2	TYPE 3	TYPE 4	Maximum Overhang
		(3 or more sides open)	(2 sides open)	(1 side open)	(Fully enclosed)	(Each end)
C1 (W41C)	75mm	4900	4100	3500	3000	900
	100mm	6100	5600	5100	3900	1100
	125mm	7400	6800	6200	4500	1300
	150mm	8700	7900	7300	5100	1500
	175mm	9600	8800	8200	5700	1600
	200mm	10600	9800	9100	6200	1700
C2 (W50C)	75mm	3300	2900	2500	2100	600
	100mm	4800	4100	3500	3100	900
	125mm	6200	5500	4700	3700	1200
	150mm	7400	6700	6000	4200	1300
	175mm	8100	7400	6900	4700	1400
	200mm	9000	8300	7700	5200	1500
C3 (W60C)	75mm	2400	2100	1800	1600	400
	100mm	3400	3000	2600	2200	500
	125mm	4500	3900	3300	2900	700
	150mm	5900	5000	4300	3200	800
	175mm	6800	5700	4900	3600	900
	200mm	7600	6700	5700	4100	1000
C4 (W70C)	75mm	1900	1600	1500	1300	300
	100mm	2700	2300	2000	1700	400
	125mm	3500	2900	2500	2100	500
	150mm	4500	3800	3200	2400	600
	175mm	5100	4300	3700	2900	700
	200mm	5900	4900	4200	3300	770

### STEP 3

### SELECT THE STYLE OF ROOF SHEETING

#### Step 3.2

#### Insulated Spans



SINGLE-SPAN NON-CYCLONIC SPAN TABLE

Wind Category	Panel Thickness	TYPE 1	TYPE 2	TYPE 3	TYPE 4	Maximum Overhang
		(3 or more sides open)	(2 sides open)	(1 side open)	(Fully enclosed)	(Each end)
N1/N2 (W28 /W33)	75mm	4900	4900	4900	4900	1700
	100mm	6300	6300	6300	6300	2200
	125mm	7600	7600	7600	7600	2600
	150mm	8200	8200	8200	8200	2900
	175mm	9600	9600	9600	9600	3300
	200mm	10600	10600	10600	10600	3700
N3 (W41)	75mm	4800	4400	4000	4000	1400
	100mm	6000	5600	5100	5100	1800
	125mm	7300	6700	6100	6100	2200
	150mm	8000	7300	6800	6800	2400
	175mm	9500	8700	8100	8100	2800
	200mm	10500	9700	8900	8900	3100
N4 (W50)	75mm	4000	3500	3200	3200	1000
	100mm	5000	4600	4200	4200	1300
	125mm	6000	5600	5000	5000	1500
	150mm	6600	6100	5500	5500	1700
	175mm	7900	7200	6700	6700	2000
	200mm	8800	8100	7400	7400	2200
N5 (W60)	75mm	3300	2600	2400	2400	600
	100mm	4200	3600	3300	3300	800
	125mm	5100	4600	4100	4100	1000
	150mm	5600	5100	4500	4500	1100
	175mm	6700	6100	5500	5500	1400
	200mm	7400	6800	6000	6000	1500

### STEP 3

### SELECT THE STYLE OF ROOF SHEETING

#### Step 3.2

#### Insulated Spans



MULTI-SPAN NON-CYCLONIC SPAN TABLE

Wind Category	Panel Thickness	TYPE 1	TYPE 2	TYPE 3	TYPE 4	Maximum Overhang
		(3 or more sides open)	(2 sides open)	(1 side open)	(Fully enclosed)	(Each end)
N1/N2 (W28 /W33)	75mm	5400	5400	5400	5400	1700
	100mm	7000	7000	7000	7000	2200
	125mm	8400	8400	8400	8400	2600
	150mm	9000	9000	9000	9000	2900
	175mm	10100	10100	10100	10100	3300
	200mm	11100	11100	11100	11100	3700
N3 (W41)	75mm	5300	4800	4400	4400	1400
	100mm	6600	6200	5600	5600	1800
	125mm	8000	7400	6700	6700	2200
	150mm	8800	8000	7500	7500	2400
	175mm	10000	9100	8500	8500	2800
	200mm	11000	10200	9300	9300	3100
N4 (W50)	75mm	4400	3900	3500	3500	1000
	100mm	5500	5100	4600	4600	1300
	125mm	6600	6200	5500	5500	1500
	150mm	7300	6700	6100	6100	1700
	175mm	8300	7600	7000	7000	2000
	200mm	9200	8500	7800	7800	2200
N5 (W60)	75mm	3300	2900	2600	2600	600
	100mm	4600	4000	3600	3600	800
	125mm	5600	5100	4500	4500	1000
	150mm	6200	5600	5000	5000	1100
	175mm	7000	6400	5800	5800	1400
	200mm	7800	7100	6300	6300	1500

### STEP 3

### SELECT THE STYLE OF ROOF SHEETING

#### Step 3.2

#### Insulated Spans



CYCLONIC SPAN TABLE

Wind Category	Panel Thickness	TYPE 1	TYPE 2	TYPE 3	TYPE 4	Maximum Overhang
		(3 or more sides open)	(2 sides open)	(1 side open)	(Fully enclosed)	(Each end)
C1 (W41C)	75mm	4900	4100	3500	3000	900
	100mm	6100	5600	5100	3900	1100
	125mm	7400	6800	6200	4500	1300
	150mm	8700	7900	7300	5100	1500
	175mm	9600	8800	8200	5700	1600
	200mm	10600	9800	9100	6200	1700
C2 (W50C)	75mm	3300	2900	2500	2100	600
	100mm	4800	4100	3500	3100	900
	125mm	6200	5500	4700	3700	1200
	150mm	7400	6700	6000	4200	1300
	175mm	8100	7400	6900	4700	1400
	200mm	9000	8300	7700	5200	1500
C3 (W60C)	75mm	2400	2100	1800	1600	400
	100mm	3400	3000	2600	2200	500
	125mm	4500	3900	3300	2900	700
	150mm	5900	5000	4300	3200	800
	175mm	6800	5700	4900	3600	900
	200mm	7600	6700	5700	4100	1000
C4 (W70C)	75mm	1900	1600	1500	1300	300
	100mm	2700	2300	2000	1700	400
	125mm	3500	2900	2500	2100	500
	150mm	4500	3800	3200	2400	600
	175mm	5100	4300	3700	2900	700
	200mm	5900	4900	4200	3300	770

**STEP 3** / SELECT THE STYLE OF ROOF SHEETING

Step 3.3 / DeltaDualCore™ Panels

➤ DeltaDualCore™ - Trim  
 ➤ DeltaDualCore™ - Orb

DeltaDualCore™

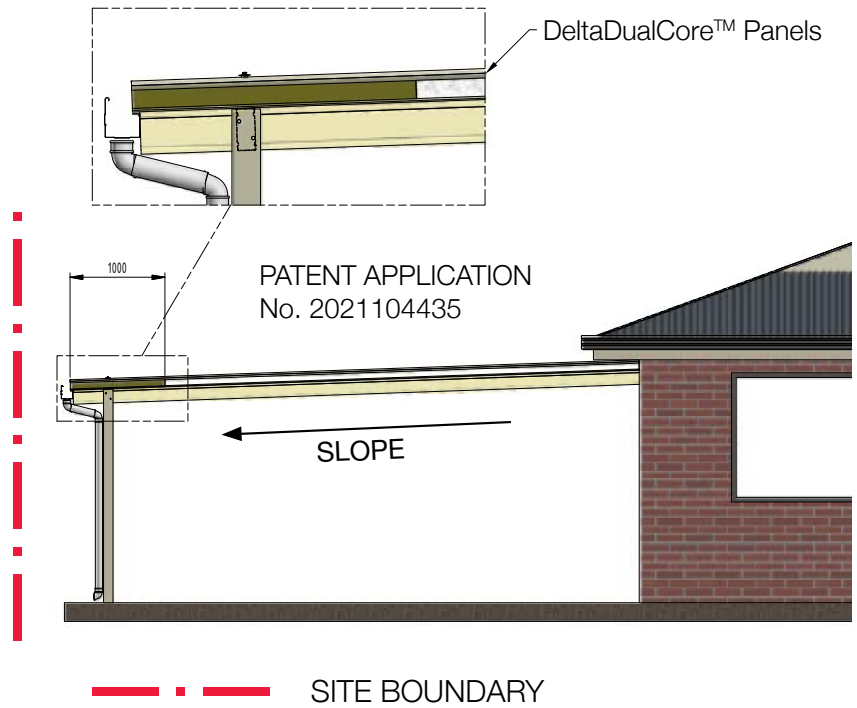

Figure A6

Panel Layout Drawing

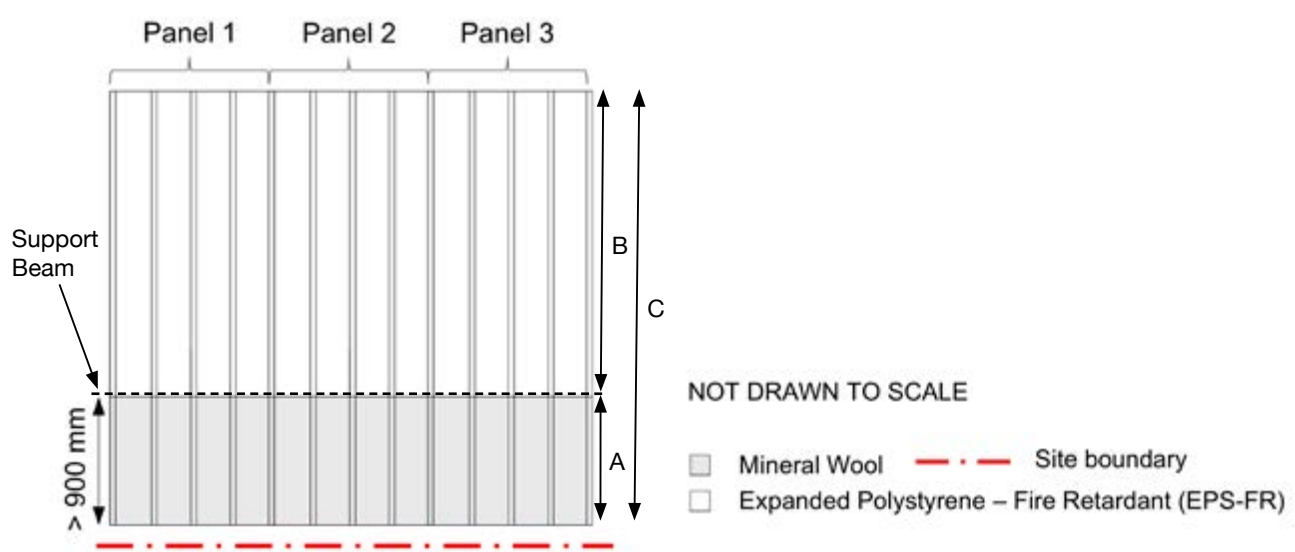

Figure A7

## STEP 3

## SELECT THE STYLE OF ROOF SHEETING

### Step 3.3 DeltaDualCore™ Panels



#### Step 3.3.1 Determine A

The length of A which is the Mineral Wool (MW) core component of Figure 6 - Panel Layout Drawing is set at 900mm. Both DeltaDualCore™-Trim & DeltaDualCore™-Orb are certified to span 900mm in all designed wind regions and patio styles when the core thickness is 75mm and above.

#### Step 3.3.2 Determine B

For Type 1/1P, Type 2 Type 3 & Type 4 structures, the length of B which is the Expanded Polystyrene Fire Retardant (EPS-FR) core component of Figure 6 - Panel Layout Drawing is measured as the section from the Support Beam back to the attachment at the Existing House structure. In the case of a Type 0 Free Standing structure it is measured to the support beam where the EPS-FR end of the panel will be fixed. The determination of the actual panel required based on the Wind Category and Structure Type can be assessed in the tables in Step 3 - Select the Style of Roof Sheeting.

#### Step 3.3.3 Determine C

The thickness of the panel required for C, which is the total length of the Insulated panel to be installed, is simply the thickness as determined in Step 3.2.2 - Determine B above, as the 900mm Mineral Wool end section is certified to span 900mm for all Wind Categories and Structure Types for both DeltaDualCore™-Trim & DeltaDualCore™-Orb.

## STEP 4

## DETERMINE THE ROOF LOAD WIDTH (RLW) ON THE BEAM

### ROOF LOAD WIDTH (RLW) SINGLE-SPAN

Roof Load Width on the House = 50% of Panel Span "A"

Roof Load Width on the Outside Beam = 50% of Panel Span "A" + Overhang "C"

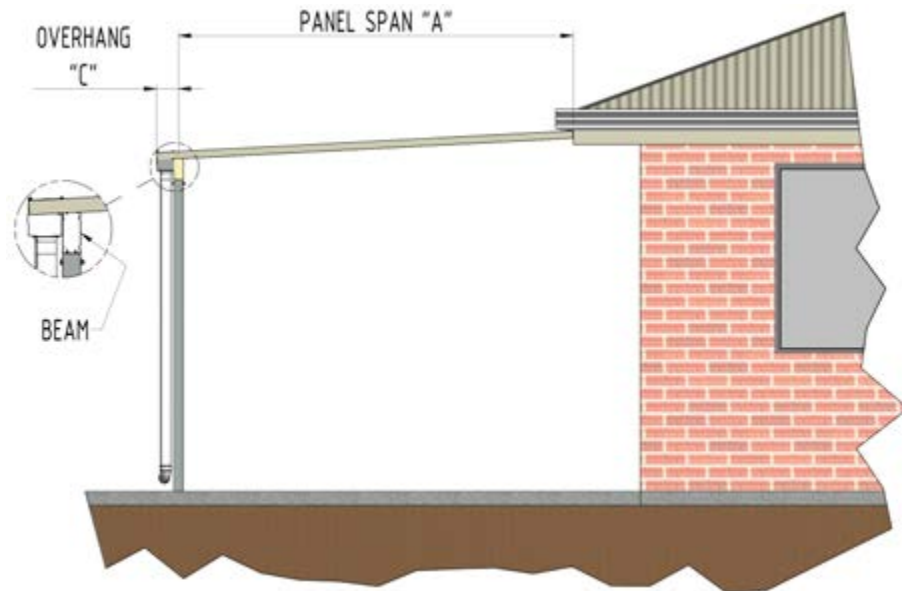

Figure A8

### ROOF LOAD WIDTH (RLW) MULTI-SPAN

Roof Load Width on the House = 50% of Panel Span "A"

Roof Load Width on the Centre Beam = 50% of Panel Span "A" + 50% of Panel Span "B"

Roof Load Width on the Outside Beam = 50% of Panel Span "B" + Overhang "C"

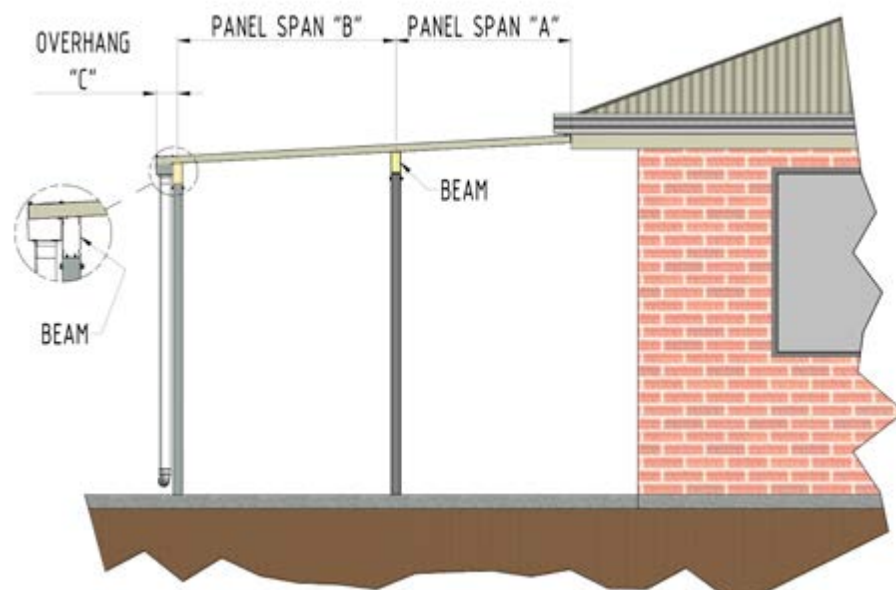

Figure A9



# STEP 5

# BEAM SPAN SELECTION

## BEAM TYPES

## STEEL

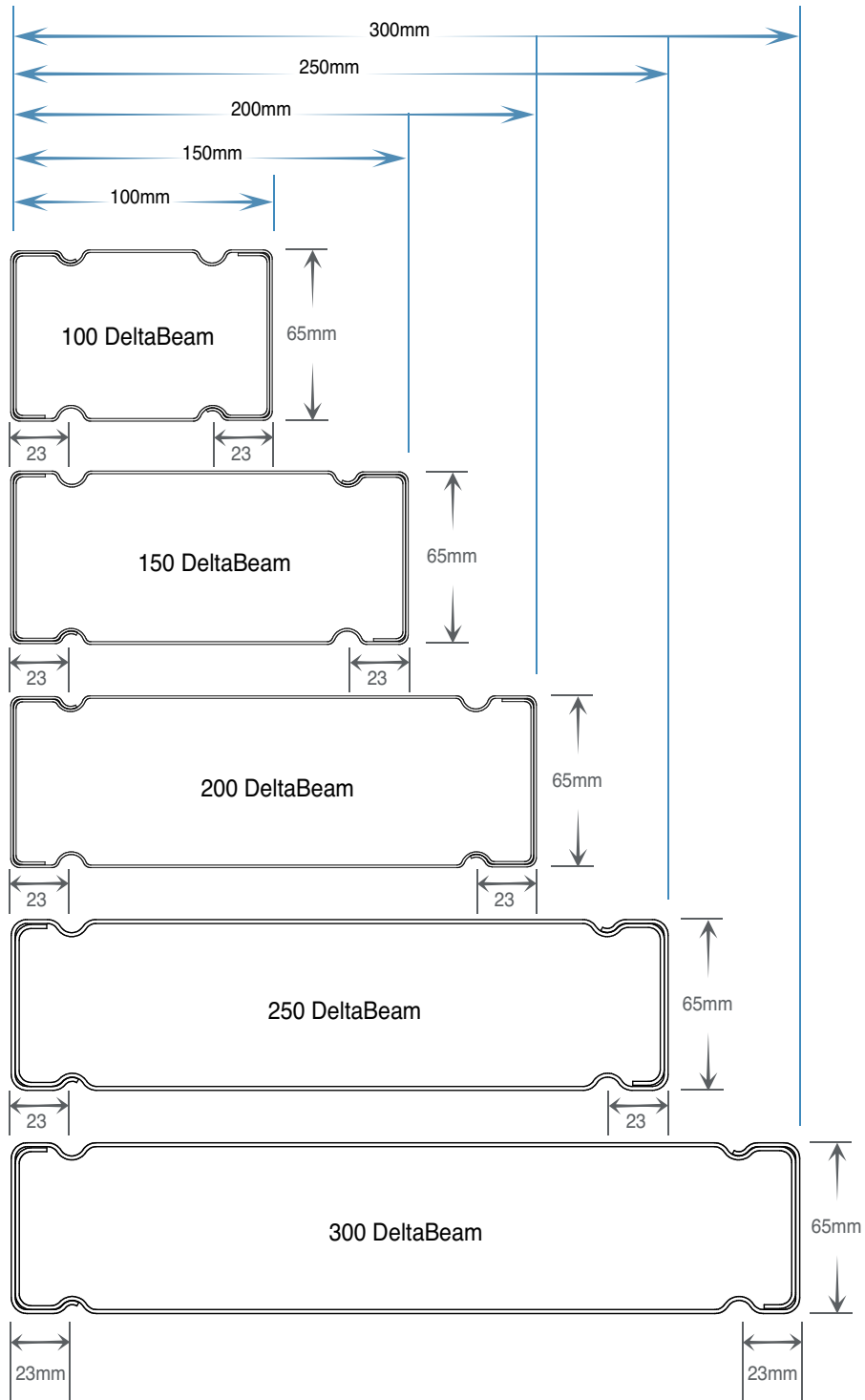

Figure A10

**STEP 5**

**BEAM SPAN SELECTION**

**DELTABEAM STEEL - 100mm SPAN TABLE**

		Single Span				Continuous Span			
V sit,500	RLW	Type 1	Type 2	Type 3	Type 4	Type 1	Type 2	Type 3	Type 4
N1 (W34)	900	6.5	6.3	5.4	6.1	8.2	8.2	7.3	8.2
	1200	6.1	5.7	4.9	5.5	7.6	7.6	6.7	7.5
	1500	5.7	5.3	4.5	5.1	7.2	7.2	6.2	6.9
	1800	5.5	5.0	4.3	4.8	6.9	6.8	5.8	6.5
	2100	5.3	4.7	4.1	4.6	6.6	6.4	5.5	6.2
	2400	5.1	4.5	3.9	4.4	6.4	6.2	5.3	5.9
	2700	5.0	4.4	3.7	4.2	6.2	5.9	5.1	5.7
	3000	4.8	4.2	3.6	4.1	6.1	5.7	4.9	5.5
	3600	4.6	4.0	3.4	3.8	5.8	5.4	4.6	5.2
	4200	4.3	3.8	3.2	3.6	5.6	5.1	4.4	4.9
	4800	4.2	3.6	3.1	3.5	5.4	4.9	4.2	4.7
5400	4.0	3.5	3.0	3.3	5.2	4.7	4.0	4.5	
6000	3.9	3.3	2.9	3.2	5.1	4.5	3.9	4.4	
N2 (W40)	900	6.4	5.6	4.8	5.4	8.2	7.5	6.5	7.3
	1200	5.8	5.0	4.4	4.9	7.6	6.9	5.9	6.6
	1500	5.4	4.7	4.0	4.5	7.2	6.4	5.5	6.1
	1800	5.1	4.4	3.8	4.3	6.9	6.0	5.2	5.8
	2100	4.8	4.2	3.6	4.0	6.5	5.7	4.9	5.5
	2400	4.6	4.0	3.5	3.9	6.2	5.4	4.7	5.3
	2700	4.4	3.9	3.3	3.7	6.0	5.2	4.5	5.0
	3000	4.3	3.7	3.2	3.6	5.8	5.0	4.4	4.9
	3600	4.0	3.5	3.0	3.4	5.4	4.8	4.1	4.6
	4200	3.8	3.3	2.9	3.2	5.2	4.5	3.9	4.4
	4800	3.6	3.2	2.7	3.1	4.9	4.3	3.7	4.2
5400	3.5	3.1	2.6	3.0	4.8	4.2	3.5	4.0	
6000	3.4	3.0	2.5	2.9	4.6	4.0	3.4	3.9	
N3/C1 (W50)	900	5.4	4.7	4.1	4.6	7.3	6.4	5.6	6.2
	1200	4.9	4.3	3.7	4.1	6.6	5.8	5.0	5.6
	1500	4.5	4.0	3.5	3.9	6.2	5.4	4.7	5.2
	1800	4.3	3.7	3.3	3.6	5.8	5.1	4.4	4.9
	2100	4.1	3.6	3.1	3.4	5.5	4.8	4.2	4.7
	2400	3.9	3.4	3.0	3.3	5.3	4.6	4.0	4.5
	2700	3.7	3.3	2.8	3.2	5.1	4.4	3.9	4.3
	3000	3.6	3.2	2.7	3.1	4.9	4.3	3.7	4.1
	3600	3.4	3.0	2.6	2.9	4.6	4.0	3.4	3.9
	4200	3.2	2.8	2.5	2.7	4.4	3.8	3.2	3.7
	4800	3.1	2.7	2.3	2.6	4.2	3.7	3.0	3.5
5400	3.0	2.6	2.3	2.5	4.0	3.5	2.8	3.3	
6000	2.9	2.5	2.2	2.4	3.9	3.3	2.6	3.1	
N4/C2 (W61)	900	4.7	4.1	3.6	4.0	6.3	5.6	4.8	5.4
	1200	4.2	3.7	3.2	3.6	5.7	5.1	4.4	4.9
	1500	3.9	3.5	3.0	3.4	5.3	4.7	4.1	4.5
	1800	3.7	3.3	2.8	3.2	5.0	4.4	3.8	4.3
	2100	3.5	3.1	2.7	3.0	4.8	4.2	3.6	4.1
	2400	3.4	3.0	2.6	2.9	4.6	4.0	3.4	3.9
	2700	3.2	2.8	2.5	2.8	4.4	3.9	3.2	3.7
	3000	3.1	2.7	2.4	2.7	4.2	3.7	3.0	3.6
	3600	2.9	2.6	2.2	2.5	4.0	3.4	2.8	3.3
	4200	2.8	2.5	2.1	2.4	3.8	3.2	2.6	3.0
	4800	2.7	2.4	2.0	2.3	3.6	3.0	2.4	2.8
5400	2.6	2.3	2.0	2.2	3.4	2.8	2.3	2.7	
6000	2.5	2.2	1.9	2.1	3.2	2.7	2.2	2.5	
N5/C3 (W74)	900	4.1	3.6	3.1	3.5	5.5	4.9	4.2	4.7
	1200	3.7	3.3	2.8	3.2	5.0	4.4	3.9	4.3
	1500	3.4	3.0	2.6	2.9	4.7	4.1	3.5	4.0
	1800	3.2	2.9	2.5	2.8	4.4	3.9	3.2	3.7
	2100	3.1	2.7	2.4	2.6	4.2	3.7	3.0	3.5
	2400	2.9	2.6	2.3	2.5	4.0	3.4	2.8	3.3
	2700	2.8	2.5	2.2	2.4	3.8	3.2	2.6	3.1
	3000	2.7	2.4	2.1	2.3	3.7	3.1	2.5	2.9
	3600	2.6	2.3	2.0	2.2	3.4	2.8	2.3	2.7
	4200	2.4	2.1	1.9	2.1	3.1	2.6	2.1	2.5
	4800	2.3	2.1	1.8	2.0	2.9	2.4	2.0	2.3
5400	2.2	2.0	1.7	1.9	2.8	2.3	1.9	2.2	
6000	2.2	1.9	1.6	1.8	2.6	2.2	1.8	2.1	

**Deflection limits adopted are:**

- L/125 under serviceability wind (assumed 50% of ULS wind)
- L/150 under maintenance load
- L/300 under dead load (30kg/m of sheeting/panel + self-weight of beam is allowed)

**DeltaBeam - Steel**

Maximum Cantilever - 25% of the Span

**STEP 5**

**BEAM SPAN SELECTION**

**DELTABEAM STEEL - 150mm SPAN TABLE**

		Single Span				Continuous Span			
V sit,500	RLW	Type 1	Type 2	Type 3	Type 4	Type 1	Type 2	Type 3	Type 4
N1 (W34)	900	8.6	8.6	7.8	8.6	10.8	10.8	10.6	10.8
	1200	8.0	8.0	7.1	8.0	10.1	10.1	9.6	10.1
	1500	7.6	7.6	6.6	7.4	9.5	9.5	8.9	9.5
	1800	7.2	7.2	6.2	7.0	9.1	9.1	8.4	9.1
	2100	7.0	6.9	5.9	6.6	8.8	8.8	8.0	8.8
	2400	6.7	6.6	5.6	6.3	8.5	8.5	7.6	8.5
	2700	6.5	6.3	5.4	6.1	8.2	8.2	7.3	8.2
	3000	6.4	6.1	5.2	5.9	8.0	8.0	7.1	8.0
	3600	6.1	5.7	4.9	5.5	7.7	7.7	6.7	7.5
	4200	5.9	5.4	4.7	5.3	7.4	7.4	6.3	7.1
	4800	5.7	5.2	4.5	5.0	7.1	7.1	6.1	6.8
5400	5.5	5.0	4.3	4.8	6.9	6.8	5.8	6.6	
6000	5.4	4.8	4.1	4.7	6.7	6.6	5.6	6.3	
N2 (W40)	900	8.6	8.0	6.9	7.8	10.8	10.8	9.4	10.5
	1200	8.0	7.3	6.3	7.1	10.1	9.9	8.6	9.6
	1500	7.6	6.8	5.9	6.6	9.5	9.2	7.9	8.9
	1800	7.2	6.4	5.5	6.2	9.1	8.7	7.5	8.4
	2100	6.9	6.1	5.2	5.9	8.8	8.2	7.1	7.9
	2400	6.6	5.8	5.0	5.6	8.5	7.9	6.8	7.6
	2700	6.4	5.6	4.8	5.4	8.2	7.6	6.5	7.3
	3000	6.2	5.4	4.6	5.2	8.0	7.3	6.3	7.1
	3600	5.8	5.1	4.4	4.9	7.7	6.9	5.9	6.6
	4200	5.5	4.8	4.2	4.6	7.4	6.5	5.6	6.3
	4800	5.3	4.6	4.0	4.4	7.1	6.3	5.3	6.0
5400	5.1	4.4	3.8	4.3	6.9	6.0	5.0	5.8	
6000	4.9	4.3	3.7	4.1	6.6	5.8	4.8	5.6	
N3/C1 (W50)	900	7.8	6.8	5.9	6.6	10.6	9.3	8.0	9.0
	1200	7.1	6.2	5.4	6.0	9.6	8.4	7.3	8.2
	1500	6.6	5.8	5.0	5.6	8.9	7.8	6.8	7.6
	1800	6.2	5.4	4.7	5.2	8.4	7.4	6.4	7.1
	2100	5.9	5.2	4.5	5.0	8.0	7.0	6.1	6.8
	2400	5.6	4.9	4.3	4.8	7.6	6.7	5.8	6.5
	2700	5.4	4.7	4.1	4.6	7.3	6.4	5.6	6.2
	3000	5.2	4.6	4.0	4.4	7.1	6.2	5.3	6.0
	3600	4.9	4.3	3.7	4.2	6.7	5.8	4.9	5.7
	4200	4.7	4.1	3.5	4.0	6.3	5.6	4.5	5.3
	4800	4.5	3.9	3.4	3.8	6.0	5.2	4.2	5.0
5400	4.3	3.8	3.3	3.6	5.8	4.9	4.0	4.7	
6000	4.1	3.6	3.1	3.5	5.6	4.7	3.8	4.4	
N4/C2 (W61)	900	6.7	5.9	5.2	5.8	9.1	8.1	7.0	7.8
	1200	6.1	5.4	4.7	5.2	8.3	7.3	6.4	7.1
	1500	5.7	5.0	4.4	4.9	7.7	6.8	5.9	6.6
	1800	5.3	4.7	4.1	4.6	7.3	6.4	5.6	6.2
	2100	5.1	4.5	3.9	4.3	6.9	6.1	5.2	5.9
	2400	4.9	4.3	3.7	4.1	6.6	5.8	4.8	5.6
	2700	4.7	4.1	3.6	4.0	6.3	5.6	4.6	5.4
	3000	4.5	4.0	3.5	3.8	6.1	5.3	4.3	5.1
	3600	4.2	3.7	3.3	3.6	5.8	4.9	4.0	4.6
	4200	4.0	3.6	3.1	3.4	5.5	4.5	3.7	4.3
	4800	3.9	3.4	3.0	3.3	5.1	4.2	3.4	4.0
5400	3.7	3.3	2.8	3.2	4.8	4.0	3.2	3.8	
6000	3.6	3.2	2.7	3.1	4.6	3.8	3.1	3.6	
N5/C3 (W74)	900	5.9	5.2	4.5	5.0	8.0	7.1	6.1	6.8
	1200	5.3	4.7	4.1	4.6	7.3	6.4	5.6	6.2
	1500	5.0	4.4	3.8	4.2	6.7	6.0	5.0	5.8
	1800	4.7	4.1	3.6	4.0	6.3	5.6	4.6	5.4
	2100	4.4	3.9	3.4	3.8	6.0	5.2	4.2	5.0
	2400	4.2	3.8	3.3	3.6	5.8	4.9	4.0	4.7
	2700	4.1	3.6	3.1	3.5	5.5	4.6	3.7	4.4
	3000	3.9	3.5	3.0	3.4	5.3	4.4	3.6	4.2
	3600	3.7	3.3	2.9	3.2	4.8	4.0	3.2	3.8
	4200	3.5	3.1	2.7	3.0	4.5	3.7	3.0	3.5
	4800	3.4	3.0	2.5	2.9	4.2	3.5	2.8	3.3
5400	3.2	2.9	2.4	2.8	3.9	3.3	2.6	3.1	
6000	3.1	2.8	2.2	2.6	3.7	3.1	2.5	2.9	

**Deflection limits adopted are:**

- L/125 under serviceability wind (assumed 50% of ULS wind)
- L/150 under maintenance load
- L/300 under dead load (30kg/m of sheeting/panel + self-weight of beam is allowed)

**DeltaBeam - Steel**

Maximum Cantilever - 25% of the Span

# STEP 5

# BEAM SPAN SELECTION

DELTABEAM STEEL - 200mm SPAN TABLE

		Single Span				Continuous Span			
V sit,500	RLW	Type 1	Type 2	Type 3	Type 4	Type 1	Type 2	Type 3	Type 4
N1 (W34)	900	10.2	10.2	9.8	10.2	12.0	12.0	12.0	12.0
	1200	9.5	9.5	8.9	9.5	11.9	11.9	11.9	11.9
	1500	9.0	9.0	8.3	9.0	11.3	11.3	11.2	11.3
	1800	8.6	8.6	7.8	8.6	10.8	10.8	10.5	10.8
	2100	8.3	8.3	7.4	8.3	10.4	10.4	10.0	10.4
	2400	8.0	8.0	7.1	7.9	10.0	10.0	9.6	10.0
	2700	7.8	7.8	6.8	7.6	9.8	9.8	9.2	9.8
	3000	7.6	7.6	6.6	7.4	9.5	9.5	8.9	9.5
	3600	7.2	7.2	6.2	6.9	9.1	9.1	8.4	9.1
	4200	6.9	6.8	5.9	6.6	8.7	8.7	7.9	8.7
	4800	6.7	6.5	5.6	6.3	8.4	8.4	7.6	8.4
5400	6.5	6.3	5.4	6.1	8.2	8.2	7.3	8.2	
6000	6.4	6.1	5.2	5.8	8.0	8.0	7.1	7.9	
N2 (W40)	900	10.2	10.1	8.7	9.7	12.0	12.0	11.8	12.0
	1200	9.5	9.2	7.9	8.8	11.9	11.9	10.7	11.9
	1500	9.0	8.5	7.3	8.2	11.3	11.3	10.0	11.1
	1800	8.6	8.0	6.9	7.7	10.8	10.8	9.4	10.5
	2100	8.3	7.6	6.6	7.3	10.4	10.3	8.9	10.0
	2400	8.0	7.3	6.3	7.0	10.0	9.9	8.5	9.5
	2700	7.8	7.0	6.0	6.7	9.8	9.5	8.2	9.2
	3000	7.6	6.7	5.8	6.5	9.5	9.2	7.9	8.8
	3600	7.2	6.4	5.5	6.1	9.1	8.6	7.4	8.3
	4200	6.9	6.0	5.2	5.8	8.7	8.2	7.1	7.9
	4800	6.6	5.8	5.0	5.6	8.4	7.8	6.6	7.6
5400	6.4	5.5	4.8	5.4	8.2	7.5	6.3	7.3	
6000	6.1	5.4	4.6	5.2	8.0	7.3	5.9	7.0	
N3/C1 (W50)	900	9.8	8.6	7.4	8.3	12.0	11.6	10.1	11.2
	1200	8.9	7.8	6.7	7.5	11.9	10.6	9.2	10.2
	1500	8.2	7.2	6.3	7.0	11.2	9.8	8.5	9.5
	1800	7.7	6.8	5.9	6.6	10.5	9.2	8.0	8.9
	2100	7.4	6.5	5.6	6.2	10.0	8.8	7.6	8.5
	2400	7.0	6.2	5.4	6.0	9.5	8.4	7.3	8.1
	2700	6.8	5.9	5.2	5.7	9.2	8.1	7.0	7.8
	3000	6.5	5.7	5.0	5.5	8.9	7.8	6.6	7.5
	3600	6.1	5.4	4.7	5.2	8.3	7.3	6.1	7.1
	4200	5.8	5.1	4.4	5.0	7.9	6.9	5.6	6.6
	4800	5.6	4.9	4.3	4.7	7.6	6.5	5.2	6.2
5400	5.4	4.7	4.1	4.6	7.3	6.1	4.9	5.8	
6000	5.2	4.6	3.9	4.4	7.0	5.8	4.7	5.5	
N4/C2 (W61)	900	8.4	7.4	6.5	7.2	11.5	10.1	8.8	9.8
	1200	7.7	6.8	5.9	6.5	10.4	9.2	8.0	8.9
	1500	7.1	6.3	5.5	6.1	9.7	8.5	7.4	8.2
	1800	6.7	5.9	5.1	5.7	9.1	8.0	7.0	7.8
	2100	6.4	5.6	4.9	5.4	8.6	7.6	6.5	7.4
	2400	6.1	5.4	4.7	5.2	8.3	7.3	6.0	7.1
	2700	5.9	5.2	4.5	5.0	7.9	7.0	5.7	6.7
	3000	5.7	5.0	4.3	4.8	7.7	6.7	5.4	6.3
	3600	5.3	4.7	4.1	4.5	7.2	6.1	4.9	5.8
	4200	5.1	4.5	3.9	4.3	6.8	5.6	4.6	5.4
	4800	4.8	4.3	3.7	4.1	6.4	5.3	4.3	5.0
5400	4.6	4.1	3.6	4.0	6.0	5.0	4.0	4.7	
6000	4.5	4.0	3.4	3.8	5.7	4.7	3.8	4.5	
N5/C3 (W74)	900	7.4	6.5	5.7	6.3	10.0	8.8	7.7	8.6
	1200	6.7	5.9	5.2	5.7	9.1	8.0	7.0	7.8
	1500	6.2	5.5	4.8	5.3	8.4	7.5	6.3	7.2
	1800	5.9	5.2	4.5	5.0	7.9	7.0	5.7	6.7
	2100	5.6	4.9	4.3	4.8	7.5	6.5	5.3	6.2
	2400	5.3	4.7	4.1	4.5	7.2	6.1	5.0	5.8
	2700	5.1	4.5	3.9	4.4	6.9	5.7	4.7	5.5
	3000	4.9	4.4	3.8	4.2	6.6	5.5	4.4	5.2
	3600	4.6	4.1	3.6	4.0	6.0	5.0	4.0	4.7
	4200	4.4	3.9	3.3	3.8	5.5	4.6	3.7	4.4
	4800	4.2	3.7	3.1	3.6	5.2	4.3	3.5	4.1
5400	4.1	3.6	3.0	3.5	4.9	4.1	3.3	3.9	
6000	3.9	3.4	2.8	3.3	4.6	3.9	3.1	3.7	

**Deflection limits adopted are:**

- L/125 under serviceability wind (assumed 50% of ULS wind)
- L/150 under maintenance load
- L/300 under dead load (30kg/m of sheeting/panel + self-weight of beam is allowed)

**DeltaBeam - Steel**

Maximum Cantilever - 25% of the Span

**STEP 5**

**BEAM SPAN SELECTION**

**DELTABEAM STEEL - 250mm SPAN TABLE**

		Single Span				Continuous Span			
V sit,500	RLW	Type 1	Type 2	Type 3	Type 4	Type 1	Type 2	Type 3	Type 4
N1 (W34)	900	12.0	12.0	12.0	12.0	12.0	12.0	12.0	12.0
	1200	11.6	11.6	11.6	11.6	12.0	12.0	12.0	12.0
	1500	10.9	10.9	10.7	10.9	12.0	12.0	12.0	12.0
	1800	10.5	10.5	10.1	10.5	12.0	12.0	12.0	12.0
	2100	10.1	10.1	9.6	10.1	12.0	12.0	12.0	12.0
	2400	9.7	9.7	9.2	9.7	12.0	12.0	12.0	12.0
	2700	9.4	9.4	8.8	9.4	11.9	11.9	11.9	11.9
	3000	9.2	9.2	8.5	9.2	11.6	11.6	11.6	11.6
	3600	8.8	8.8	8.0	8.8	11.1	11.1	10.9	11.1
	4200	8.5	8.5	7.6	8.5	10.6	10.6	10.3	10.6
	4800	8.2	8.2	7.3	8.2	10.3	10.3	9.9	10.3
5400	7.9	7.9	7.0	7.9	10.0	10.0	9.5	10.0	
6000	7.7	7.7	6.8	7.6	9.7	9.7	9.2	9.7	
N2 (W40)	900	12.0	12.0	11.3	12.0	12.0	12.0	12.0	12.0
	1200	11.6	11.6	10.3	11.5	12.0	12.0	12.0	12.0
	1500	10.9	10.9	9.5	10.7	12.0	12.0	12.0	12.0
	1800	10.5	10.4	9.0	10.1	12.0	12.0	12.0	12.0
	2100	10.1	9.9	8.5	9.6	12.0	12.0	11.6	12.0
	2400	9.7	9.5	8.2	9.1	12.0	12.0	11.1	12.0
	2700	9.4	9.1	7.8	8.8	11.9	11.9	10.7	11.9
	3000	9.2	8.8	7.6	8.5	11.6	11.6	10.3	11.5
	3600	8.8	8.3	7.1	8.0	11.1	11.1	9.7	10.8
	4200	8.5	7.9	6.8	7.6	10.6	10.6	9.2	10.3
	4800	8.2	7.5	6.5	7.3	10.3	10.2	8.6	9.8
5400	7.9	7.2	6.2	7.0	10.0	9.8	8.1	9.5	
6000	7.7	7.0	6.0	6.7	9.7	9.5	7.7	9.1	
N3/C1 (W50)	900	12.0	11.2	9.7	10.8	12.0	12.0	12.0	12.0
	1200	11.5	10.1	8.8	9.8	12.0	12.0	11.9	12.0
	1500	10.7	9.4	8.2	9.1	12.0	12.0	11.1	12.0
	1800	10.1	8.9	7.7	8.6	12.0	12.0	10.4	11.6
	2100	9.6	8.4	7.3	8.1	12.0	11.4	9.9	11.0
	2400	9.2	8.0	7.0	7.8	12.0	10.9	9.5	10.6
	2700	8.8	7.7	6.7	7.5	11.9	10.5	9.1	10.1
	3000	8.5	7.5	6.5	7.2	11.5	10.1	8.6	9.8
	3600	8.0	7.0	6.1	6.8	10.9	9.5	7.8	9.2
	4200	7.6	6.7	5.8	6.5	10.3	9.0	7.3	8.6
	4800	7.3	6.4	5.5	6.2	9.9	8.4	6.8	8.0
5400	7.0	6.1	5.3	5.9	9.5	7.9	6.4	7.5	
6000	6.7	5.9	5.1	5.7	9.1	7.5	6.1	7.2	
N4/C2 (W61)	900	11.0	9.7	8.4	9.4	12.0	12.0	11.4	12.0
	1200	10.0	8.8	7.7	8.5	12.0	12.0	10.4	11.6
	1500	9.3	8.2	7.1	7.9	12.0	11.1	9.6	10.7
	1800	8.7	7.7	6.7	7.4	11.8	10.4	9.0	10.1
	2100	8.3	7.3	6.4	7.1	11.2	9.9	8.4	9.6
	2400	7.9	7.0	6.1	6.8	10.8	9.5	7.8	9.2
	2700	7.6	6.7	5.8	6.5	10.3	9.1	7.4	8.7
	3000	7.4	6.5	5.6	6.3	10.0	8.6	7.0	8.2
	3600	6.9	6.1	5.3	5.9	9.4	7.9	6.4	7.5
	4200	6.6	5.8	5.0	5.6	8.8	7.3	5.9	6.9
	4800	6.3	5.5	4.8	5.4	8.2	6.8	5.5	6.5
5400	6.0	5.3	4.6	5.2	7.8	6.4	5.2	6.1	
6000	5.8	5.2	4.4	5.0	7.4	6.1	4.9	5.8	
N5/C3 (W74)	900	9.6	8.5	7.4	8.2	12.0	11.5	10.0	11.1
	1200	8.7	7.7	6.7	7.5	11.8	10.5	9.1	10.1
	1500	8.1	7.2	6.2	6.9	11.0	9.7	8.1	9.4
	1800	7.6	6.7	5.9	6.5	10.3	9.1	7.4	8.7
	2100	7.2	6.4	5.6	6.2	9.8	8.4	6.9	8.0
	2400	6.9	6.1	5.3	5.9	9.4	7.9	6.4	7.5
	2700	6.7	5.9	5.1	5.7	9.0	7.4	6.0	7.1
	3000	6.4	5.7	4.9	5.5	8.5	7.1	5.7	6.7
	3600	6.0	5.3	4.7	5.2	7.8	6.4	5.2	6.1
	4200	5.7	5.1	4.3	4.9	7.2	6.0	4.8	5.7
	4800	5.5	4.9	4.1	4.7	6.7	5.6	4.5	5.3
5400	5.3	4.7	3.8	4.5	6.3	5.3	4.3	5.0	
6000	5.1	4.5	3.6	4.2	6.0	5.0	4.1	4.8	

**Deflection limits adopted are:**

- L/125 under serviceability wind (assumed 50% of ULS wind)
- L/150 under maintenance load
- L/300 under dead load (30kg/m of sheeting/panel + self-weight of beam is allowed)

**DeltaBeam - Steel**

Maximum Cantilever - 25% of the Span

**STEP 5**

**BEAM SPAN SELECTION**

**DELTABEAM STEEL - 300mm SPAN TABLE**

		Single Span				Continuous Span			
V sit,500	RLW	Type 1	Type 2	Type 3	Type 4	Type 1	Type 2	Type 3	Type 4
N1 (W34)	900	12.0	12.0	12.0	12.0	12.0	12.0	12.0	12.0
	1200	12.0	12.0	12.0	12.0	12.0	12.0	12.0	12.0
	1500	12.0	12.0	12.0	12.0	12.0	12.0	12.0	12.0
	1800	11.7	11.7	11.7	11.7	12.0	12.0	12.0	12.0
	2100	11.2	11.2	11.1	11.2	12.0	12.0	12.0	12.0
	2400	10.9	10.9	10.6	10.9	12.0	12.0	12.0	12.0
	2700	10.5	10.5	10.2	10.5	12.0	12.0	12.0	12.0
	3000	10.3	10.3	9.9	10.3	12.0	12.0	12.0	12.0
	3600	9.8	9.8	9.3	9.8	12.0	12.0	12.0	12.0
	4200	9.4	9.4	8.8	9.4	11.9	11.9	11.9	11.9
	4800	9.1	9.1	8.4	9.1	11.5	11.5	11.5	11.5
5400	8.9	8.9	8.1	8.9	11.1	11.1	11.0	11.1	
6000	8.6	8.6	7.8	8.6	10.9	10.9	10.4	10.9	
N2 (W40)	900	12.0	12.0	12.0	12.0	12.0	12.0	12.0	12.0
	1200	12.0	12.0	11.9	12.0	12.0	12.0	12.0	12.0
	1500	12.0	12.0	11.0	12.0	12.0	12.0	12.0	12.0
	1800	11.7	11.7	10.4	11.6	12.0	12.0	12.0	12.0
	2100	11.2	11.2	9.9	11.1	12.0	12.0	12.0	12.0
	2400	10.9	10.9	9.4	10.6	12.0	12.0	12.0	12.0
	2700	10.5	10.5	9.1	10.2	12.0	12.0	12.0	12.0
	3000	10.3	10.2	8.8	9.8	12.0	12.0	11.9	12.0
	3600	9.8	9.6	8.3	9.2	12.0	12.0	11.2	12.0
	4200	9.4	9.1	7.8	8.8	11.9	11.9	10.5	11.9
	4800	9.1	8.7	7.5	8.4	11.5	11.5	9.8	11.4
5400	8.9	8.4	7.2	8.1	11.1	11.1	9.2	10.9	
6000	8.6	8.1	7.0	7.8	10.9	10.9	8.7	10.4	
N3/C1 (W50)	900	12.0	12.0	11.2	12.0	12.0	12.0	12.0	12.0
	1200	12.0	11.7	10.2	11.3	12.0	12.0	12.0	12.0
	1500	12.0	10.9	9.4	10.5	12.0	12.0	12.0	12.0
	1800	11.7	10.2	8.9	9.9	12.0	12.0	12.0	12.0
	2100	11.1	9.7	8.4	9.4	12.0	12.0	11.5	12.0
	2400	10.6	9.3	8.1	9.0	12.0	12.0	10.9	12.0
	2700	10.2	9.0	7.8	8.7	12.0	12.0	10.3	11.7
	3000	9.8	8.6	7.5	8.4	12.0	11.7	9.8	11.3
	3600	9.3	8.1	7.0	7.9	12.0	11.0	8.9	10.5
	4200	8.8	7.7	6.7	7.5	11.9	10.2	8.3	9.7
	4800	8.4	7.4	6.4	7.1	11.4	9.6	7.7	9.1
5400	8.1	7.1	6.2	6.9	10.9	9.0	7.3	8.6	
6000	7.8	6.9	5.9	6.6	10.4	8.6	6.9	8.1	
N4/C2 (W61)	900	12.0	11.2	9.8	10.9	12.0	12.0	12.0	12.0
	1200	11.6	10.2	8.9	9.9	12.0	12.0	12.0	12.0
	1500	10.7	9.5	8.2	9.2	12.0	12.0	11.2	12.0
	1800	10.1	8.9	7.7	8.6	12.0	12.0	10.3	11.7
	2100	9.6	8.5	7.4	8.2	12.0	11.5	9.5	11.1
	2400	9.2	8.1	7.0	7.8	12.0	11.0	8.9	10.4
	2700	8.8	7.8	6.8	7.5	12.0	10.3	8.4	9.8
	3000	8.5	7.5	6.5	7.3	11.6	9.8	7.9	9.3
	3600	8.0	7.1	6.1	6.8	10.8	9.0	7.3	8.5
	4200	7.6	6.7	5.8	6.5	10.0	8.3	6.7	7.9
	4800	7.3	6.4	5.6	6.2	9.4	7.8	6.3	7.4
5400	7.0	6.2	5.3	6.0	8.8	7.3	5.9	7.0	
6000	6.8	6.0	5.0	5.8	8.4	6.9	5.6	6.6	
N5/C3 (W74)	900	11.1	9.8	8.5	9.5	12.0	12.0	11.6	12.0
	1200	10.1	8.9	7.8	8.6	12.0	12.0	10.3	11.7
	1500	9.4	8.3	7.2	8.0	12.0	11.2	9.2	10.8
	1800	8.8	7.8	6.8	7.5	12.0	10.4	8.4	9.9
	2100	8.4	7.4	6.4	7.2	11.4	9.6	7.8	9.1
	2400	8.0	7.1	6.2	6.9	10.8	9.0	7.3	8.5
	2700	7.7	6.8	5.9	6.6	10.2	8.5	6.9	8.1
	3000	7.4	6.6	5.7	6.4	9.7	8.0	6.5	7.6
	3600	7.0	6.2	5.3	6.0	8.8	7.3	5.9	7.0
	4200	6.6	5.9	4.9	5.7	8.2	6.8	5.5	6.5
	4800	6.4	5.6	4.6	5.4	7.6	6.3	5.2	6.0
5400	6.1	5.3	4.3	5.1	7.2	6.0	4.9	5.7	
6000	5.9	5.1	4.1	4.8	6.8	5.7	4.6	5.4	

**Deflection limits adopted are:**

- L/125 under serviceability wind (assumed 50% of ULS wind)
- L/150 under maintenance load
- L/300 under dead load (30kg/m of sheeting/panel + self-weight of beam is allowed)

**DeltaBeam - Steel**

Maximum Cantilever - 25% of the Span

BEAM TYPES

ALUMINIUM

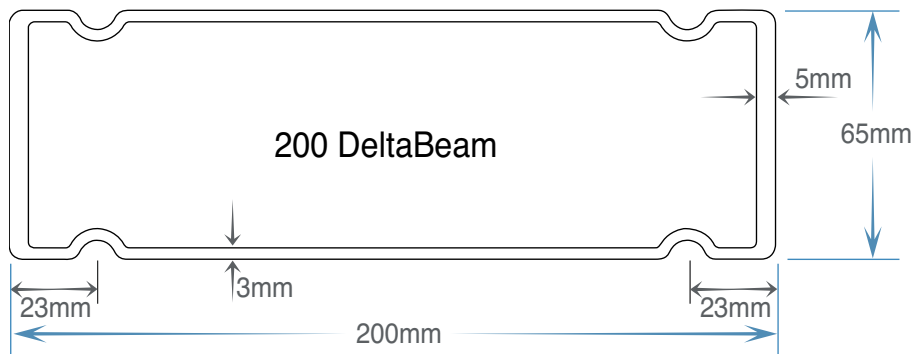
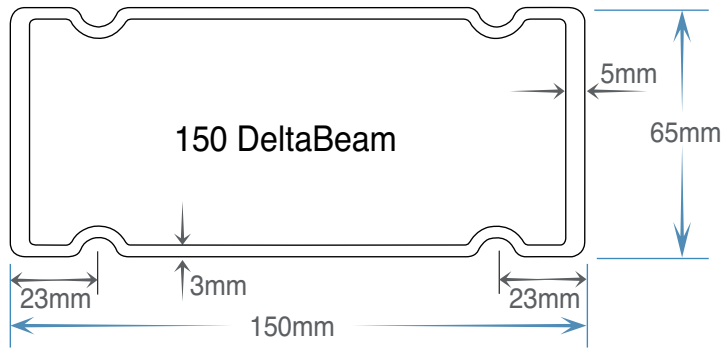

Figure A11

**STEP 5**

**BEAM SPAN SELECTION**

**DELTABEAM ALUMINIUM - 150mm SPAN TABLE**

		Single Span				Continuous Span			
V sit,500	RLW	Type 1	Type 2	Type 3	Type 4	Type 1	Type 2	Type 3	Type 4
N1 (W34)	900	7.9	7.9	6.9	7.8	9.9	9.9	9.4	9.9
	1200	7.3	7.3	6.3	7.1	9.2	9.2	8.5	9.2
	1500	6.9	6.8	5.8	6.5	8.7	8.7	7.9	8.7
	1800	6.6	6.4	5.5	6.2	8.3	8.3	7.4	8.3
	2100	6.4	6.1	5.2	5.9	8.0	8.0	7.1	7.9
	2400	6.2	5.8	5.0	5.6	7.7	7.7	6.8	7.6
	2700	6.0	5.6	4.8	5.4	7.5	7.5	6.5	7.3
	3000	5.8	5.4	4.6	5.2	7.3	7.3	6.3	7.1
	3600	5.6	5.1	4.4	4.9	7.0	6.9	5.9	6.6
	4200	5.3	4.8	4.1	4.6	6.7	6.5	5.6	6.3
	4800	5.2	4.6	4.0	4.4	6.5	6.3	5.4	6.0
5400	5.0	4.4	3.8	4.3	6.3	6.0	5.2	5.8	
6000	4.9	4.3	3.7	4.1	6.2	5.8	5.0	5.6	
N2 (W40)	900	7.9	7.1	6.1	6.9	9.9	9.7	8.3	9.3
	1200	7.3	6.5	5.6	6.2	9.2	8.8	7.6	8.5
	1500	6.9	6.0	5.2	5.8	8.7	8.2	7.0	7.9
	1800	6.5	5.7	4.9	5.5	8.3	7.7	6.6	7.4
	2100	6.2	5.4	4.6	5.2	8.0	7.3	6.3	7.0
	2400	5.9	5.1	4.4	5.0	7.7	7.0	6.0	6.7
	2700	5.7	4.9	4.3	4.8	7.5	6.7	5.8	6.5
	3000	5.5	4.8	4.1	4.6	7.3	6.5	5.6	6.2
	3600	5.1	4.5	3.9	4.3	7.0	6.1	5.3	5.9
	4200	4.9	4.3	3.7	4.1	6.6	5.8	5.0	5.6
	4800	4.7	4.1	3.5	3.9	6.3	5.5	4.8	5.3
5400	4.5	3.9	3.4	3.8	6.1	5.3	4.6	5.1	
6000	4.3	3.8	3.3	3.7	5.9	5.1	4.4	5.0	
N3/C1 (W50)	900	6.9	6.1	5.2	5.9	9.3	8.2	7.1	7.9
	1200	6.3	5.5	4.8	5.3	8.5	7.5	6.5	7.2
	1500	5.8	5.1	4.4	4.9	7.9	6.9	6.0	6.7
	1800	5.5	4.8	4.2	4.6	7.4	6.5	5.7	6.3
	2100	5.2	4.6	4.0	4.4	7.0	6.2	5.4	6.0
	2400	5.0	4.4	3.8	4.2	6.7	5.9	5.1	5.7
	2700	4.8	4.2	3.6	4.1	6.5	5.7	4.9	5.5
	3000	4.6	4.1	3.5	3.9	6.3	5.5	4.8	5.3
	3600	4.3	3.8	3.3	3.7	5.9	5.2	4.5	5.0
	4200	4.1	3.6	3.1	3.5	5.6	4.9	4.3	4.8
	4800	3.9	3.5	3.0	3.3	5.4	4.7	4.1	4.5
5400	3.8	3.3	2.9	3.2	5.1	4.5	3.9	4.4	
6000	3.7	3.2	2.8	3.1	5.0	4.4	3.8	4.2	
N4/C2 (W61)	900	6.0	5.3	4.6	5.1	8.1	7.1	6.2	6.9
	1200	5.4	4.8	4.2	4.6	7.4	6.5	5.6	6.3
	1500	5.0	4.4	3.9	4.3	6.8	6.0	5.2	5.8
	1800	4.7	4.2	3.6	4.0	6.4	5.7	4.9	5.5
	2100	4.5	4.0	3.4	3.8	6.1	5.4	4.7	5.2
	2400	4.3	3.8	3.3	3.7	5.8	5.1	4.5	5.0
	2700	4.1	3.6	3.2	3.5	5.6	5.0	4.3	4.8
	3000	4.0	3.5	3.1	3.4	5.4	4.8	4.2	4.6
	3600	3.8	3.3	2.9	3.2	5.1	4.5	3.9	4.4
	4200	3.6	3.1	2.7	3.0	4.8	4.3	3.7	4.1
	4800	3.4	3.0	2.6	2.9	4.6	4.1	3.5	4.0
5400	3.3	2.9	2.5	2.8	4.5	3.9	3.3	3.8	
6000	3.2	2.8	2.4	2.7	4.3	3.8	3.2	3.7	
N5/C3 (W74)	900	5.2	4.6	4.0	4.5	7.1	6.2	5.4	6.0
	1200	4.7	4.2	3.6	4.0	6.4	5.7	4.9	5.5
	1500	4.4	3.9	3.4	3.8	6.0	5.3	4.6	5.1
	1800	4.1	3.7	3.2	3.5	5.6	5.0	4.3	4.8
	2100	3.9	3.5	3.0	3.4	5.3	4.7	4.1	4.6
	2400	3.8	3.3	2.9	3.2	5.1	4.5	3.9	4.4
	2700	3.6	3.2	2.8	3.1	4.9	4.3	3.8	4.2
	3000	3.5	3.1	2.7	3.0	4.7	4.2	3.6	4.0
	3600	3.3	2.9	2.5	2.8	4.5	3.9	3.4	3.8
	4200	3.1	2.8	2.4	2.7	4.2	3.7	3.1	3.6
	4800	3.0	2.6	2.3	2.5	4.0	3.6	2.9	3.4
5400	2.9	2.5	2.2	2.5	3.9	3.4	2.7	3.2	
6000	2.8	2.5	2.1	2.4	3.8	3.2	2.6	3.1	

**Deflection limits adopted are:**

- L/125 under serviceability wind (assumed 50% of ULS wind)
- L/150 under maintenance load
- L/300 under dead load (30kg/m of sheeting/panel + self-weight of beam is allowed)

**DeltaBeam - Aluminium**

Maximum Cantilever - 25% of the Span



# STEP 5

# BEAM SPAN SELECTION

DELTABEAM ALUMINIUM - 200mm SPAN TABLE

		Single Span				Continuous Span			
V sit,500	RLW	Type 1	Type 2	Type 3	Type 4	Type 1	Type 2	Type 3	Type 4
N1 (W34)	900	9.3	9.3	8.7	9.3	11.7	11.7	11.7	11.7
	1200	8.7	8.7	7.9	8.7	10.9	10.9	10.7	10.9
	1500	8.2	8.2	7.3	8.2	10.3	10.3	10.0	10.3
	1800	7.9	7.9	6.9	7.8	9.9	9.9	9.4	9.9
	2100	7.6	7.6	6.6	7.4	9.5	9.5	8.9	9.5
	2400	7.3	7.3	6.3	7.0	9.2	9.2	8.5	9.2
	2700	7.1	7.0	6.0	6.8	8.9	8.9	8.2	8.9
	3000	6.9	6.8	5.8	6.5	8.7	8.7	7.9	8.7
	3600	6.6	6.4	5.5	6.2	8.3	8.3	7.4	8.3
	4200	6.4	6.1	5.2	5.8	8.0	8.0	7.1	7.9
	4800	6.1	5.8	5.0	5.6	7.7	7.7	6.8	7.6
5400	6.0	5.6	4.8	5.4	7.5	7.5	6.5	7.3	
6000	5.8	5.4	4.6	5.2	7.3	7.3	6.3	7.0	
N2 (W40)	900	9.3	9.0	7.7	8.7	11.7	11.7	10.5	11.7
	1200	8.7	8.1	7.0	7.9	10.9	10.9	9.5	10.7
	1500	8.2	7.6	6.5	7.3	10.3	10.3	8.8	9.9
	1800	7.9	7.1	6.1	6.9	9.9	9.7	8.3	9.3
	2100	7.6	6.8	5.8	6.5	9.5	9.2	7.9	8.9
	2400	7.3	6.5	5.6	6.2	9.2	8.8	7.6	8.5
	2700	7.1	6.2	5.4	6.0	8.9	8.4	7.3	8.1
	3000	6.9	6.0	5.2	5.8	8.7	8.1	7.0	7.9
	3600	6.5	5.6	4.9	5.5	8.3	7.7	6.6	7.4
	4200	6.1	5.4	4.6	5.2	8.0	7.3	6.3	7.0
	4800	5.9	5.1	4.4	5.0	7.7	7.0	6.0	6.7
5400	5.7	4.9	4.3	4.8	7.5	6.7	5.8	6.5	
6000	5.5	4.8	4.1	4.6	7.3	6.5	5.6	6.1	
N3/C1 (W50)	900	8.7	7.6	6.6	7.4	11.7	10.3	9.0	10.0
	1200	7.9	6.9	6.0	6.7	10.7	9.4	8.1	9.1
	1500	7.3	6.4	5.6	6.2	9.9	8.7	7.6	8.4
	1800	6.9	6.0	5.2	5.8	9.3	8.2	7.1	7.9
	2100	6.5	5.7	5.0	5.6	8.9	7.8	6.8	7.5
	2400	6.3	5.5	4.8	5.3	8.5	7.5	6.5	7.2
	2700	6.0	5.3	4.6	5.1	8.2	7.2	6.2	6.9
	3000	5.8	5.1	4.4	4.9	7.9	6.9	6.0	6.7
	3600	5.5	4.8	4.2	4.6	7.4	6.5	5.6	6.3
	4200	5.2	4.6	4.0	4.4	7.0	6.2	5.4	6.0
	4800	5.0	4.4	3.8	4.2	6.7	5.9	5.0	5.7
5400	4.8	4.2	3.6	4.1	6.5	5.7	4.7	5.5	
6000	4.6	4.0	3.5	3.9	6.3	5.5	4.5	5.3	
N4/C2 (W61)	900	7.5	6.6	5.8	6.4	10.2	9.0	7.8	8.7
	1200	6.8	6.0	5.2	5.8	9.3	8.2	7.1	7.9
	1500	6.3	5.6	4.9	5.4	8.6	7.6	6.6	7.3
	1800	6.0	5.3	4.6	5.1	8.1	7.1	6.2	6.9
	2100	5.7	5.0	4.3	4.8	7.7	6.8	5.9	6.6
	2400	5.4	4.8	4.1	4.6	7.3	6.5	5.6	6.3
	2700	5.2	4.6	4.0	4.4	7.1	6.2	5.4	6.0
	3000	5.0	4.4	3.9	4.3	6.8	6.0	5.2	5.8
	3600	4.7	4.2	3.6	4.0	6.4	5.7	4.7	5.5
	4200	4.5	4.0	3.4	3.8	6.1	5.4	4.4	5.1
	4800	4.3	3.8	3.3	3.7	5.8	5.1	4.1	4.8
5400	4.1	3.6	3.2	3.5	5.6	4.8	3.9	4.5	
6000	4.0	3.5	3.1	3.4	5.4	4.5	3.7	4.3	
N5/C3 (W74)	900	6.6	5.8	5.0	5.6	8.9	7.9	6.8	7.6
	1200	6.0	5.3	4.6	5.1	8.1	7.1	6.2	6.9
	1500	5.5	4.9	4.3	4.7	7.5	6.6	5.8	6.4
	1800	5.2	4.6	4.0	4.4	7.1	6.2	5.4	6.0
	2100	4.9	4.4	3.8	4.2	6.7	5.9	5.1	5.7
	2400	4.7	4.2	3.6	4.0	6.4	5.7	4.7	5.5
	2700	4.5	4.0	3.5	3.9	6.2	5.5	4.5	5.2
	3000	4.4	3.9	3.4	3.8	6.0	5.2	4.2	5.0
	3600	4.1	3.6	3.2	3.5	5.6	4.8	3.9	4.5
	4200	3.9	3.5	3.0	3.4	5.3	4.4	3.6	4.2
	4800	3.8	3.3	2.9	3.2	5.0	4.1	3.4	3.9
5400	3.6	3.2	2.8	3.1	4.7	3.9	3.2	3.7	
6000	3.5	3.1	2.7	3.0	4.4	3.7	3.0	3.5	

**Deflection limits adopted are:**

L/125 under serviceability wind (assumed 50% of ULS wind)

L/150 under maintenance load

L/300 under dead load (30kg/m of sheeting/panel + self-weight of beam is allowed)

**DeltaBeam - Aluminium**

Maximum Cantilever - 25% of the Span

## STEP 6

## CALCULATE THE UPLIFT ON THE POSTS

### Step 6.1

Select the Load Width on each Post, refer to the diagram below:

#### SINGLE-SPAN

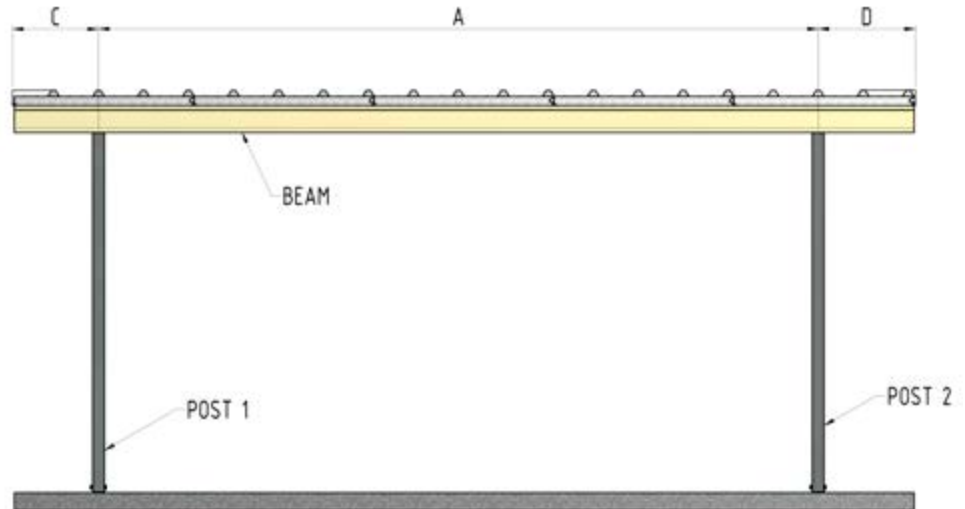

Figure A12

Load Width - **Post 1** = Half (0.5) of "A" metres + "C" metres

Load Width - **Post 2** = Half (0.5) of "A" metres + "D" metres

#### MULTI-SPAN

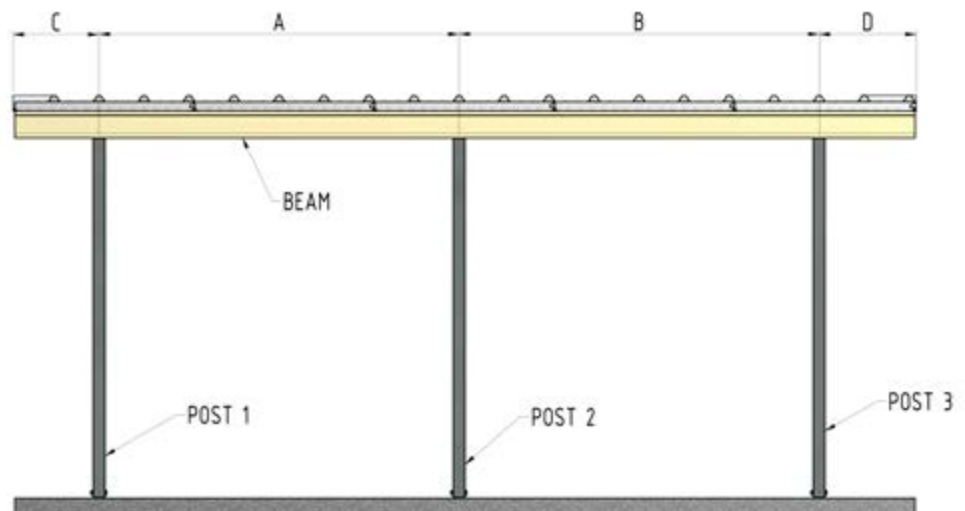

Figure A13

Load Width - **Post 1** = Half (0.5) of "A" metres + "C" metres

Load Width - **Post 2** = Half (0.5) of "A" metres + Half (0.5) "B" metres

Load Width - **Post 3** = Half (0.5) of "B" metres + "D" metres

## STEP 6

## CALCULATE THE UPLIFT ON THE POSTS

### Step 6.2

### Calculate the Uplift

**Uplift on the Post (kN) = Uplift on the Beam (kN/m) x Load Width of the Post (metres).**

UPLIFT LOADS ON THE BEAM (kN/m) - NON-CYCLONIC					
Wind Category	Load Width (mm)	TYPE 1	TYPE 2	TYPE 3	TYPE 4
N1/N2 (W33)	1500	0.91	1.73	2.07	2.25
	1800	1.10	2.08	2.49	2.70
	2100	1.28	2.42	2.90	3.14
	2400	1.47	2.77	3.32	3.59
	2700	1.65	3.11	3.73	4.04
	3000	1.83	3.46	4.15	4.49
	3300	2.01	3.80	4.56	4.94
	3600	2.20	4.15	4.98	5.39
	3900	2.38	4.49	5.39	5.84
	4200	2.56	4.84	5.81	6.29
	4500	2.74	5.18	6.22	6.74
	4800	2.93	5.53	6.64	7.19
	5100	3.11	5.88	7.05	7.64
	5400	3.39	6.40	7.67	8.32
6000	3.66	6.91	8.29	8.99	
N3 (W50)	1500	1.49	2.70	3.24	3.51
	1800	1.75	3.24	3.74	4.21
	2100	2.00	3.78	4.24	4.91
	2400	2.29	4.32	5.04	5.62
	2700	2.57	4.86	5.83	6.32
	3000	2.86	5.40	6.48	7.02
	3300	3.14	5.94	7.13	7.72
	3600	3.43	6.48	7.78	8.43
	3900	3.71	7.02	8.42	9.13
	4200	4.00	7.56	9.07	9.83
	4500	4.28	8.10	9.72	10.53
	4800	4.57	8.64	10.37	11.23
	5100	4.86	9.18	11.02	11.93
	5400	5.29	9.99	11.99	12.99
6000	5.71	10.80	12.96	14.04	
N4 (W61)	1500	2.13	4.01	4.82	5.22
	1800	2.56	4.83	5.79	6.27
	2100	2.98	5.63	6.75	7.31
	2400	3.41	6.43	7.72	8.36
	2700	3.83	7.23	8.68	9.40
	3000	4.35	8.04	9.65	10.45
	3300	4.86	8.84	10.61	11.49
	3600	5.20	9.65	11.58	12.53
	3900	5.53	10.45	12.54	13.56
	4200	5.96	11.26	13.51	14.62
	4500	6.38	12.06	14.47	15.67
	4800	6.81	12.86	15.44	16.72
	5100	7.23	13.66	16.40	17.76

## STEP 6

## CALCULATE THE UPLIFT ON THE POSTS

### Step 6.2

### Calculate the Uplift

**Uplift on the Post (kN) = Uplift on the Beam (kN/m) x Load Width of the Post (metres).**

UPLIFT LOADS ON THE BEAM (kN/m) - CYCLONIC					
Wind Category	Load Width (mm)	TYPE 1	TYPE 2	TYPE 3	TYPE 4
C1 (W50)	1500	1.43	2.70	3.24	4.86
	1800	1.72	3.24	3.89	5.83
	2100	2.00	3.78	4.54	6.80
	2400	2.29	4.32	5.19	7.78
	2700	2.57	4.86	5.83	8.75
	3000	2.86	5.40	6.48	9.72
	3300	3.14	5.94	7.13	10.69
	3600	4.43	6.48	7.78	11.67
	3900	3.71	7.01	8.42	12.64
	4200	4.00	7.56	9.07	13.61
	4500	4.28	8.10	9.72	14.58
	4800	4.57	8.64	10.37	15.55
	5100	4.86	9.18	11.02	16.52
	5400	5.29	9.99	11.99	17.98
6000	5.71	10.80	12.96	19.44	
C2 (W51)	1500	2.13	4.01	4.82	7.23
	1800	2.56	4.83	5.79	8.68
	2100	2.98	5.63	6.75	10.13
	2400	3.41	6.43	7.72	11.58
	2700	3.83	7.23	8.68	13.02
	3000	4.26	8.04	9.65	14.47
	3300	4.68	8.84	10.61	15.91
	3600	5.11	9.65	11.58	17.36
	3900	5.53	10.45	12.54	18.81
	4200	5.96	11.26	13.52	20.26
	4500	6.38	12.06	14.47	21.70
	4800	6.81	12.86	14.44	23.15
5100	7.23	13.66	16.40	24.59	
C3 (W74)	1500	3.13	5.91	7.10	10.65
	1800	3.76	7.10	8.52	12.78
	2100	4.38	8.28	9.94	14.90
	2400	5.01	9.47	11.36	17.03
	2700	5.63	10.65	12.77	19.16
	3000	6.26	11.83	14.19	21.29
	3300	6.88	13.01	15.61	23.42
	3600	7.51	14.19	17.03	25.55
	3900	8.13	15.38	18.45	27.68
	4200	8.76	16.56	19.87	29.81

**Timber Post to Stirrup (see Figure A14)**

Tabulated Data is in kN

Fixing Details		Footing Details					
Number of Bolts and Diameter	Uplift (kN)	Depth of Pad d(mm)	D=450mm (kN)	D=600mm (kN)	Depth of Pad d(mm)	D=450mm (kN)	D=600mm (kN)
2/M10 Bolts	6.75	600	2.25	3.99	1200	4.49	7.98
2/M12 Bolts	9.65	750	2.81	4.99	1500	5.61	9.98
2/M16 Bolts	16.7	900	3.37	5.99	1800	6.74	11.98
		1000	3.74	6.65	2000	7.49	13.31

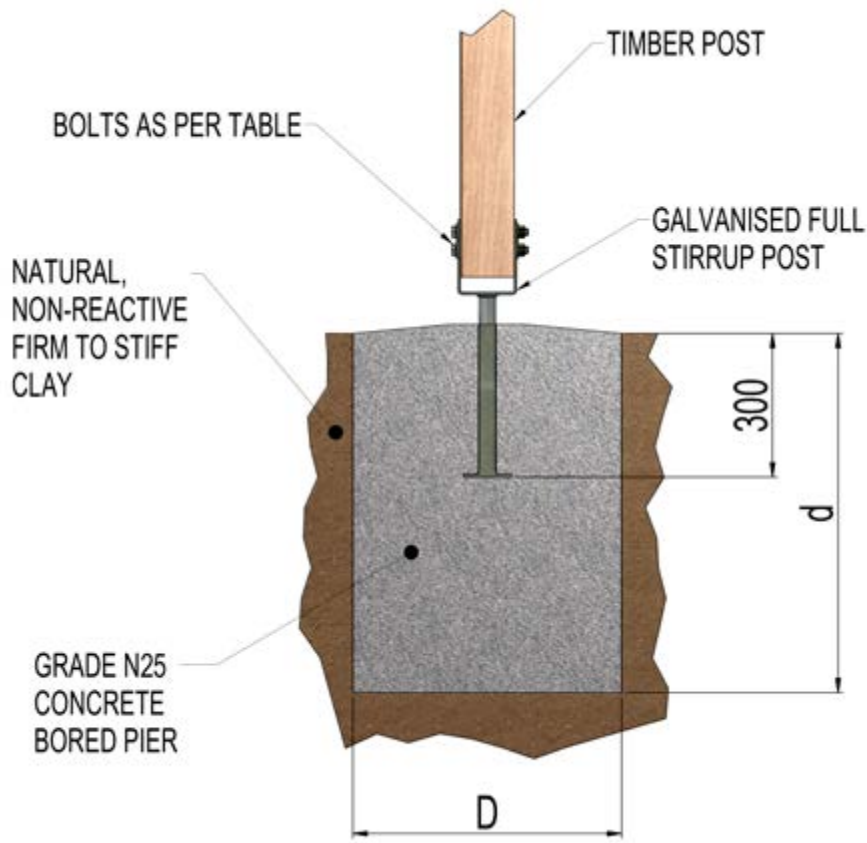
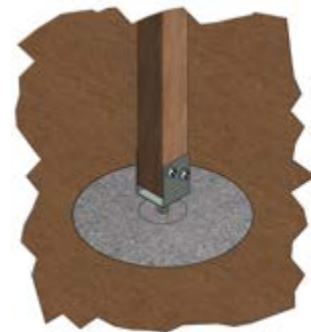

Figure A14



**Steel Post to Pad Footing with Slab Over (see Figure A15)**

Tabulated Data is in kN

Footing Details							
Depth of Pad d(mm)	D=450mm (kN)	D=600mm (kN)	F	Depth of Pad d(mm)	D=450mm (kN)	D=600mm (kN)	F
600	6.59	8.7	100	1200	9.2	12.69	100
750	7.52	9.7	100	1500	10.32	14.69	100
900	8.08	10.7	100	1800	11.45	16.69	100
1000	8.45	11.36	100	2000	12.19	18.02	100

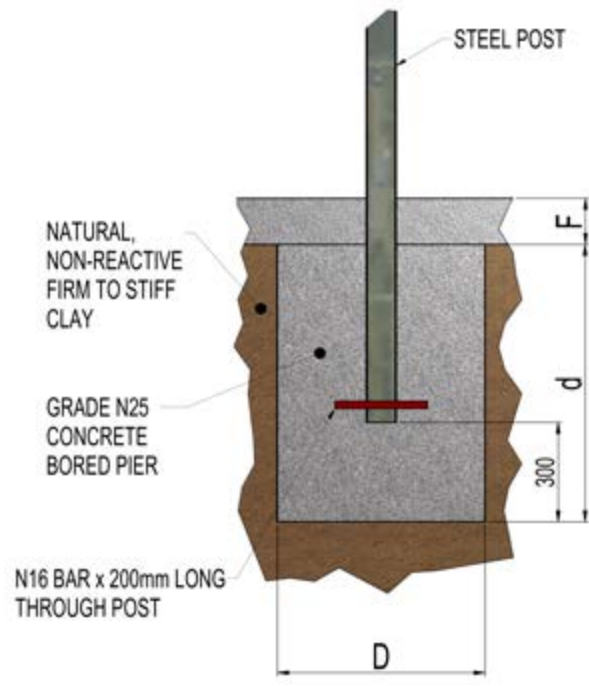
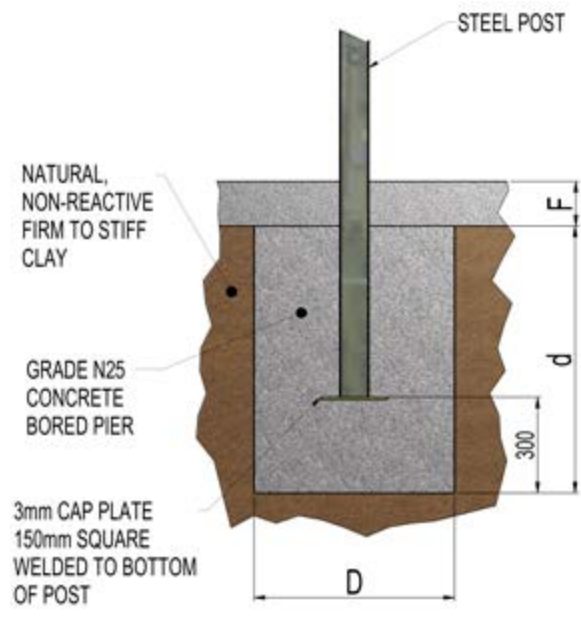

Figure A15

**Steel Post to Pad Footing (see Figure A16)**

Tabulated Data is in kN

**Footing Details**

Depth of Pad d(mm)	D=450mm (kN)	D=600mm (kN)	Depth of Pad d(mm)	D=450mm (kN)	D=600mm (kN)
600	2.25	3.99	1200	4.49	7.98
750	2.81	4.99	1500	5.61	9.98
900	3.37	5.99	1800	6.74	11.98
1000	3.74	6.65	2000	7.49	13.31

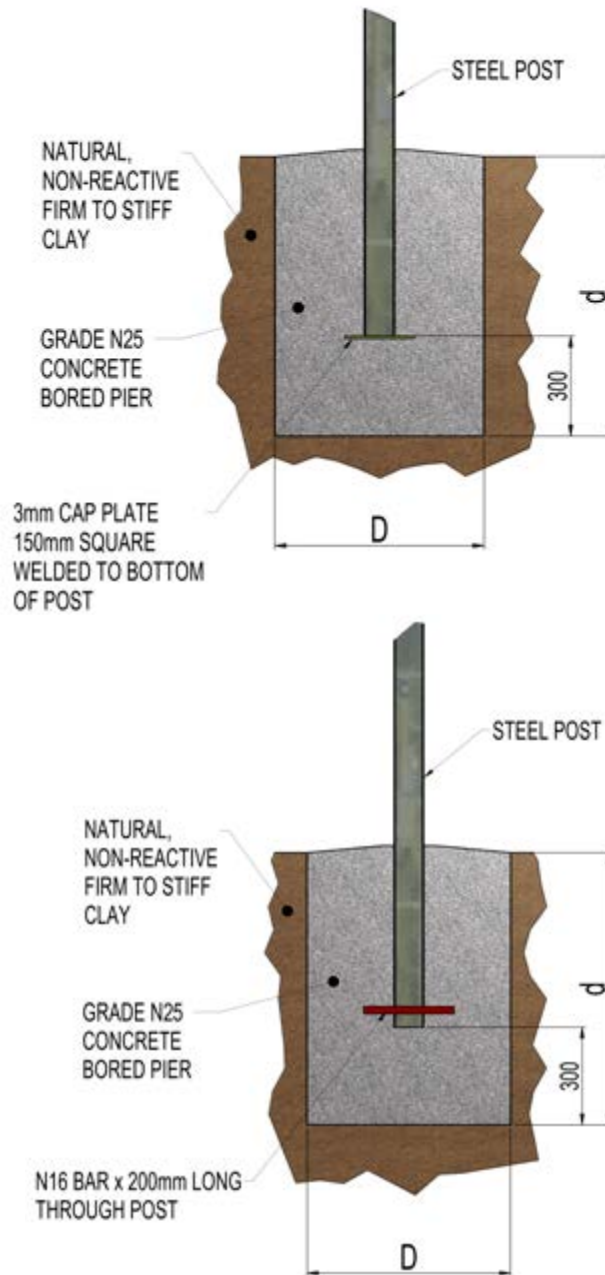

Figure A16

**Column to Slab (see Figure A17)**

Tabulated Data is in kN

Fixing Details		
Post Size (mm)	Cross Bolt - M10	Cross Bolt - M12
65x65x1.6 Steel	3.6	3.6
65x65x1.6 Aluminium	3.4	3.6

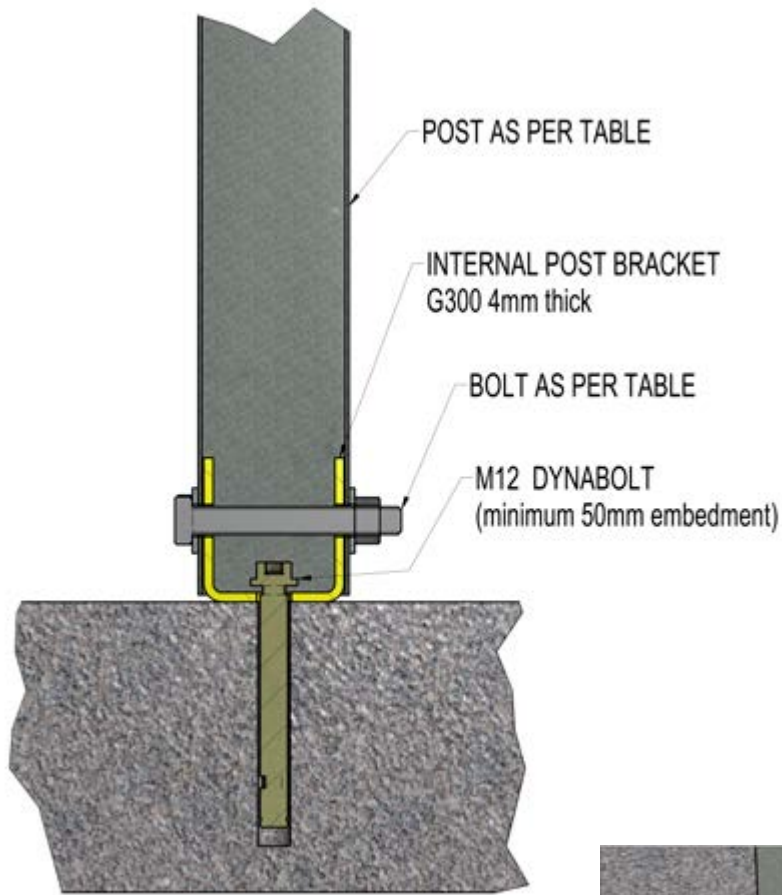
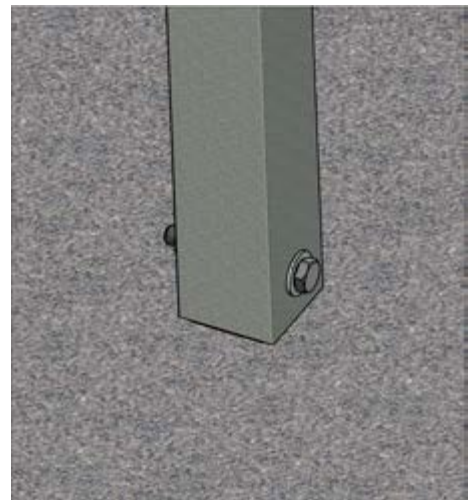

Figure A17





**Column to Slab (see Figure A18)**

Tabulated Data is in kN

**Fixing Details**

Post Size (mm)	Tek Screws 13g x 25mm
65x65x1.6 Steel	3.6
65x65x1.6 Aluminium	3.4

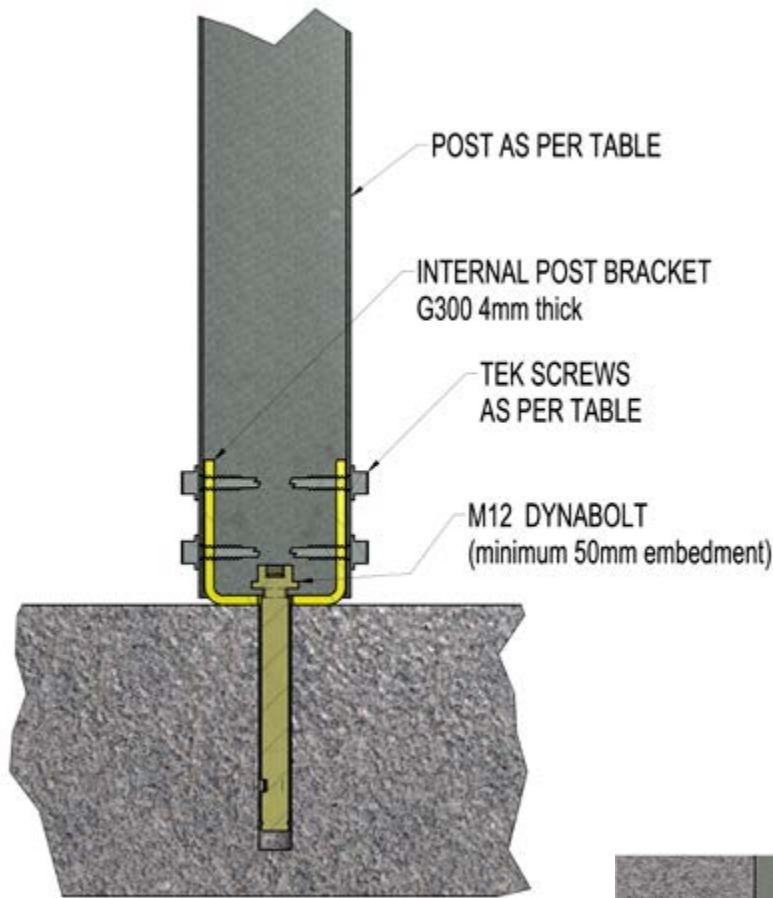
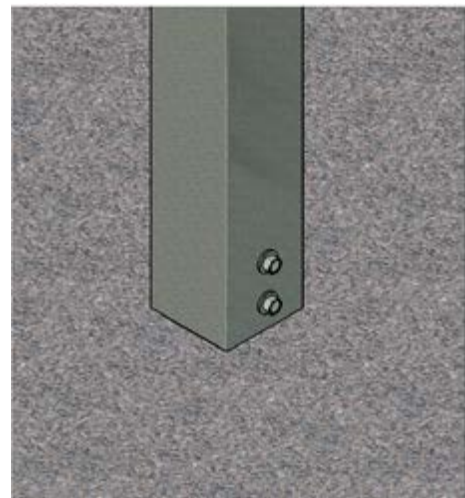

Figure A18



**Column to Slab (see Figure A19)**

Tabulated Data is in kN

Fixing Details		
Post Size (mm)	Cross Bolt - M10	Cross Bolt - M12
65x65x1.6 Steel	4.8	4.61

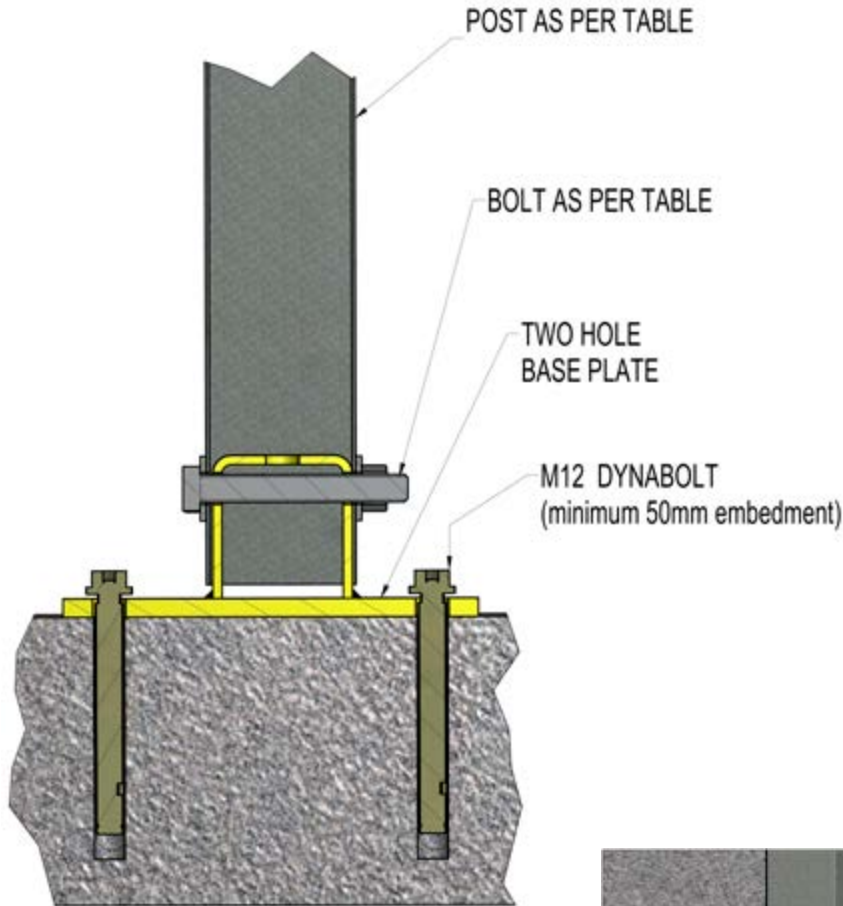
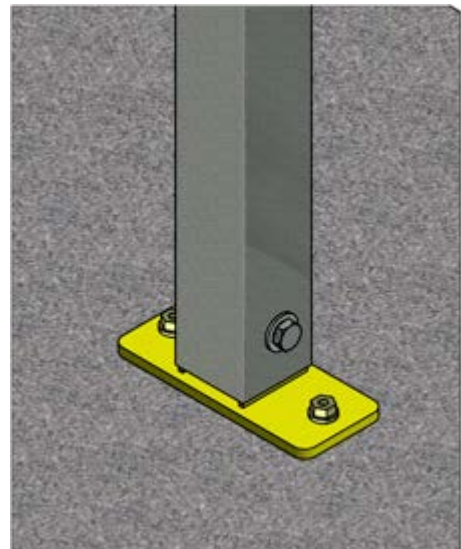

Figure A19



**Column to Slab (see Figure A20)**

Tabulated Data is in kN

**Fixing Details**

Post Size (mm)	Cross Bolt - M10	Cross Bolt - M12
100x100x2.5 Steel	12.0	14.4
100x100x2.5 Aluminium	12.0	14.4

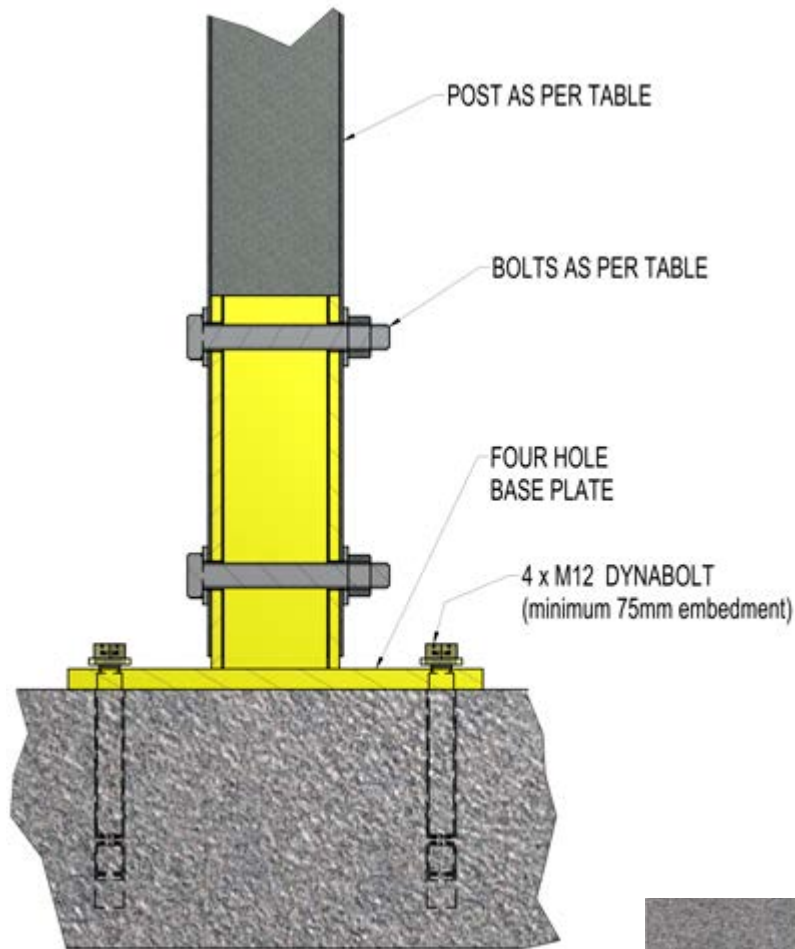
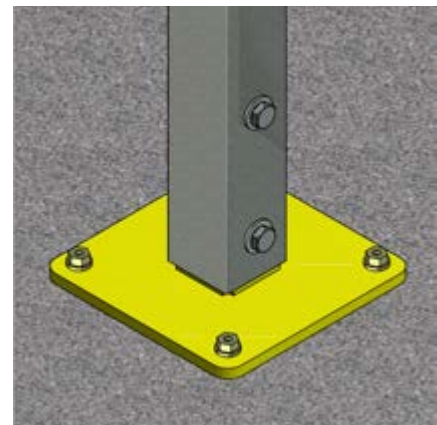

Figure A20



**Timber Post to Timber Beam (see Figure A21)**

Tabulated Data is in kN

**Fixing Details**

Number of Bolts and Diameter	Uplift (kN)
2/M10 Bolts	6.75
2/M12 Bolts	9.65
2/M16 Bolts	16.7

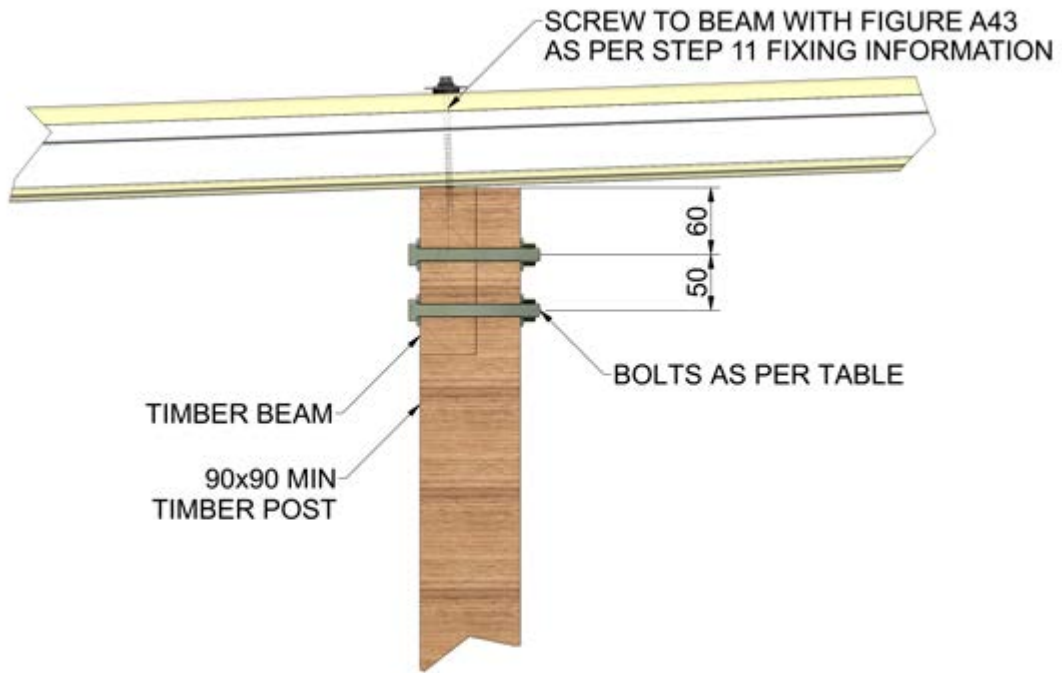

Figure A21

**Timber Post to DeltaBeam (see Figure A22)**

Tabulated Data is in kN

**Fixing Details**

Number of Bolts and Diameter	Uplift (kN)
2/M10 Bolts	6.75
2/M12 Bolts	9.65
2/M16 Bolts	16.7

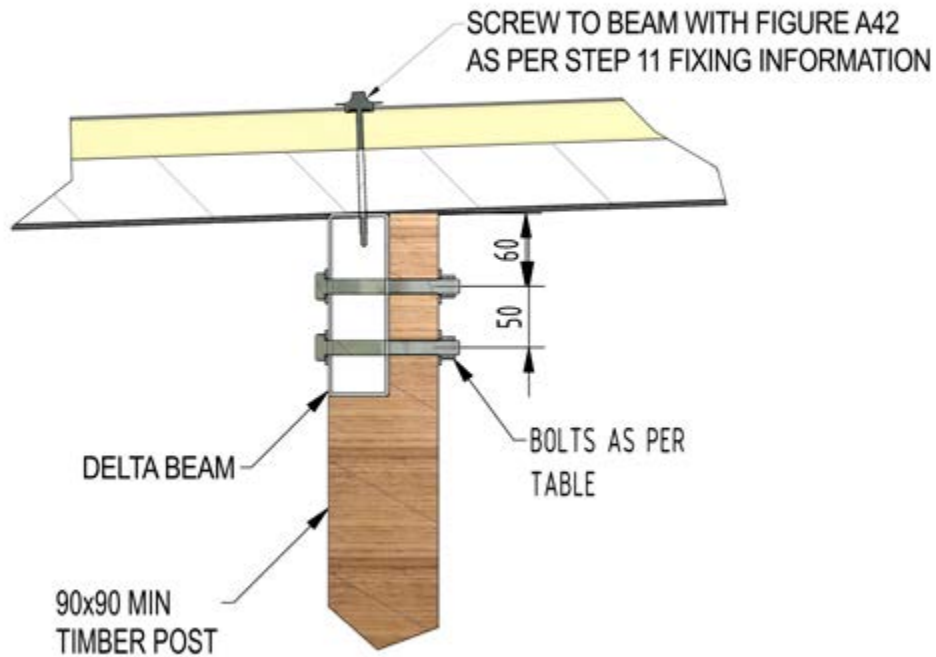

Figure A22

**Delta™ Steel or Aluminium Beam to Post (see Figure A23)**

Tabulated Data is in kN

**Fixing Details**

Number of Bolts and Diameter	Uplift (kN)
2/M10 Bolts	14.4
2/M12 Bolts	17.28

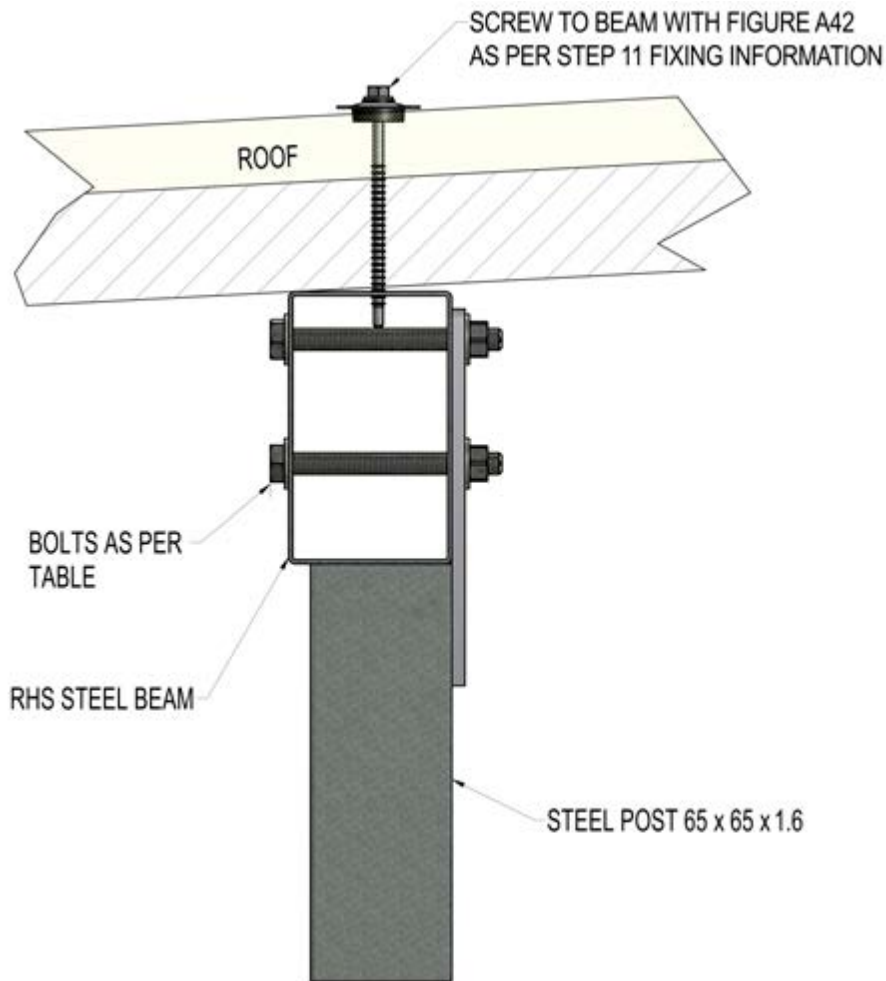

Figure A23

**Delta™ Steel or Aluminium Beam to Post (see Figure A24)**

Tabulated Data is in kN

Post Size (mm)	Fixing Details	
	Cross Bolt - M10	Cross Bolt - M12
65x65x1.6 Steel	3.6	3.6
65x65x1.6 Aluminium	3.4	3.6

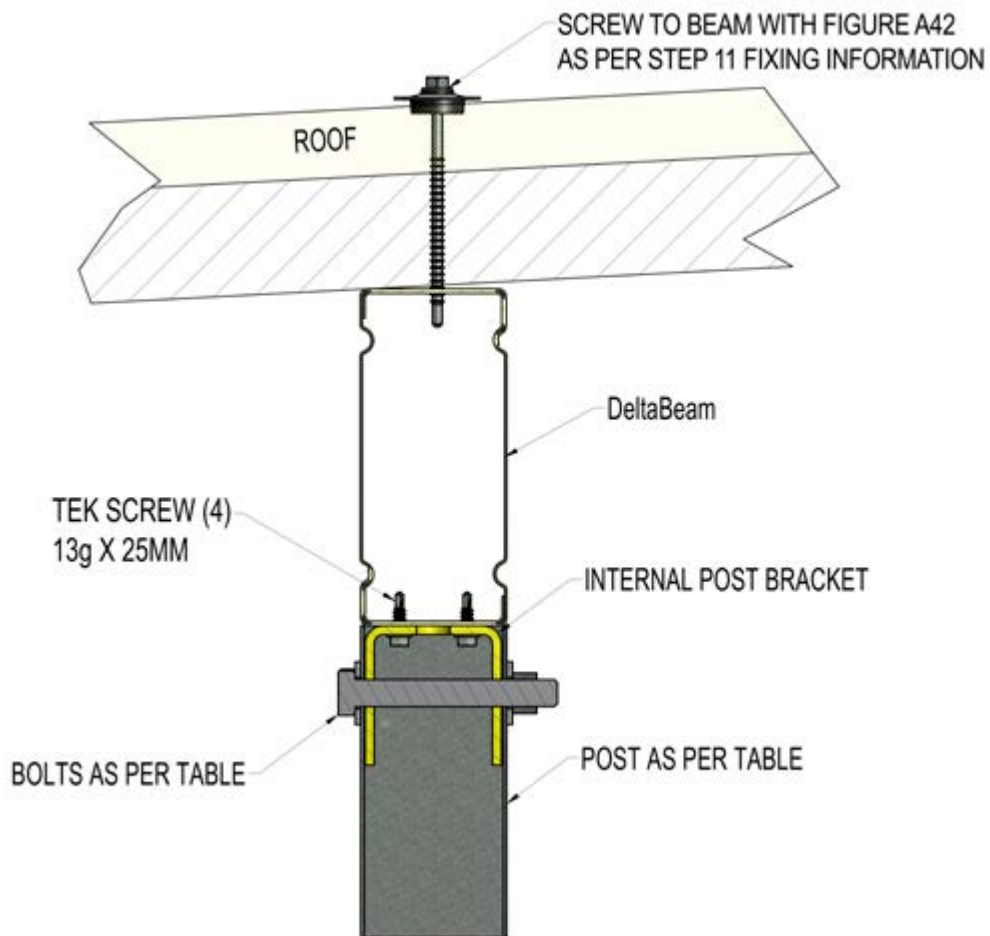

Figure A24

**Delta™ Steel or Aluminium Beam to Post (see Figure A25)**

Tabulated Data is in kN

Fixing Details		
Beam Size (mm)	Cross Bolt - M10/2	Cross Bolt - M12/2
1.0mm	22	26.4
1.2mm	26.4	31.68
1.6mm	35.2	42.24

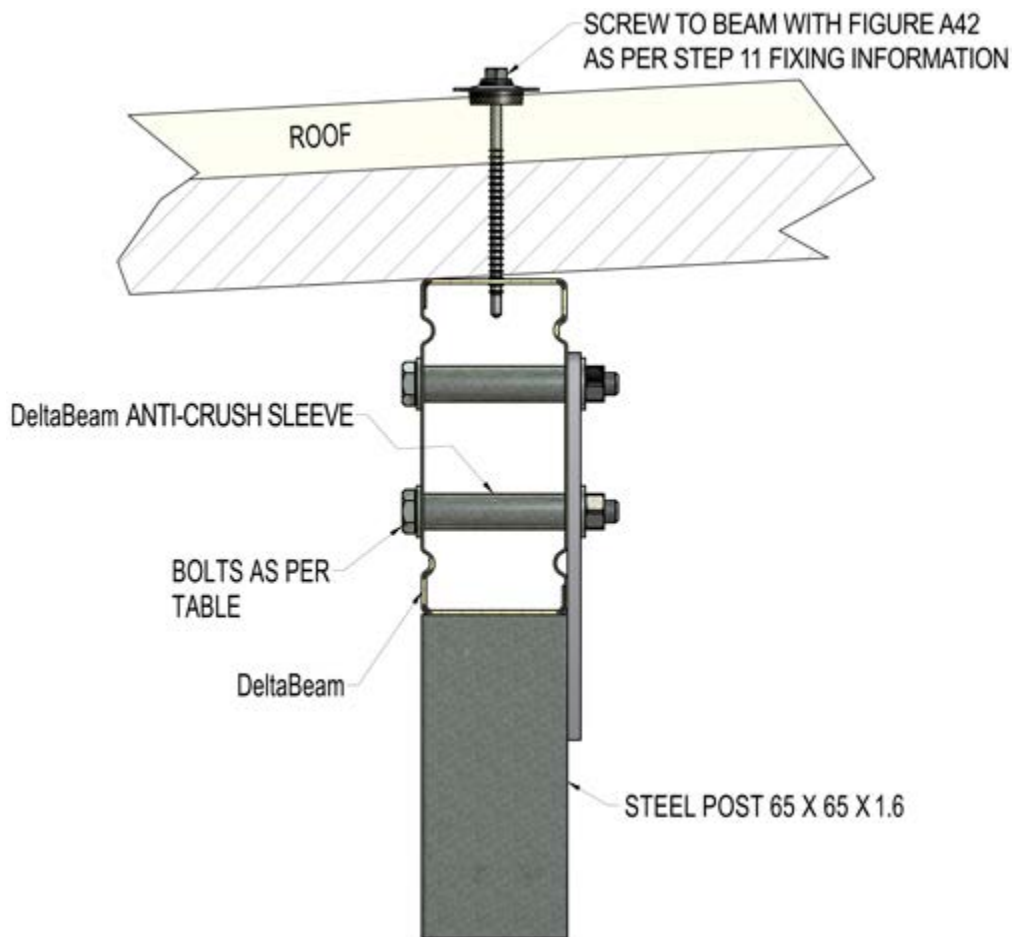

Figure A25



**Delta™ Steel or Aluminium Beam to Post (see Figure A26)**

Tabulated Data is in kN

Fixing Details		
Beam Size (mm)	Cross Bolt - M10/4	Cross Bolt - M12/4
1.0mm Steel	44	52.8
1.2mm Steel	52.8	63.36
1.6mm Steel	70.4	84.48
3.0mm Aluminium	49.6	59.62

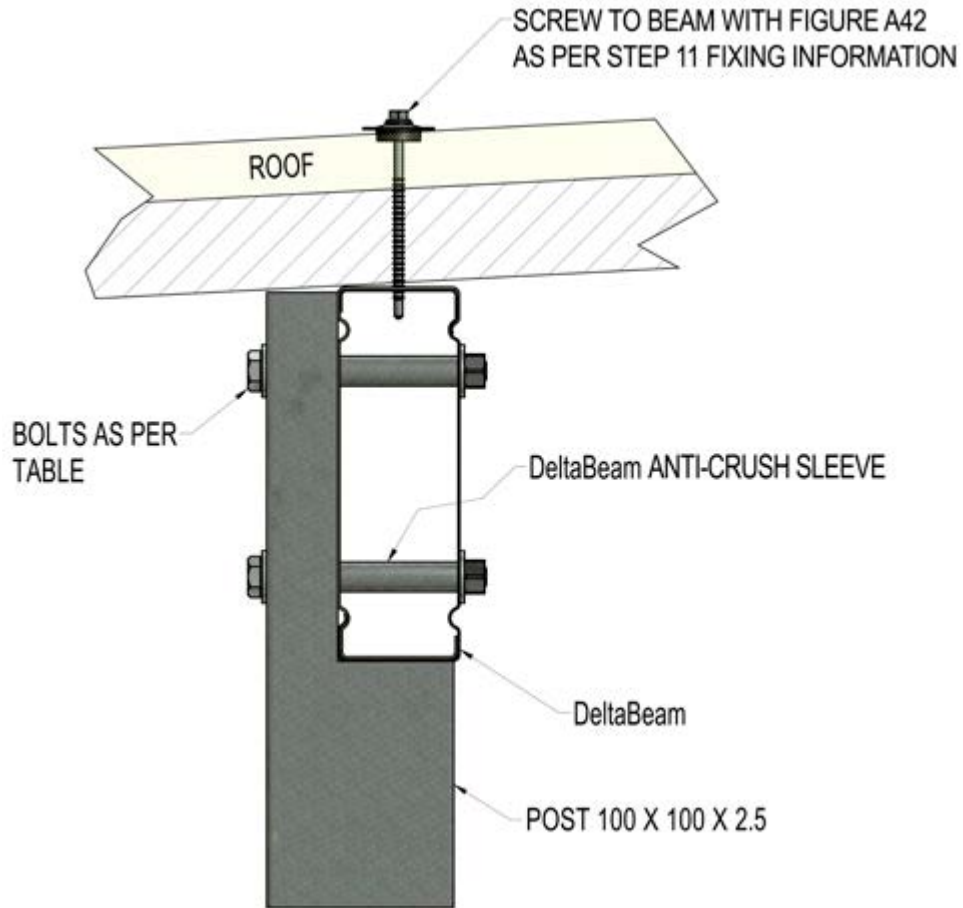

Figure A26

**Delta™ Steel or Aluminium Beam to Post (see Figure A27)**

Tabulated Data is in kN

**Fixing Details**

Post Size (mm)	Tek Screws 13g x 25mm (4off)	Tek Screws 13g x 25mm (8off)
65x65x1.6 Steel	4.68	9.36
65x65x1.6 Aluminium	3.76	7.53

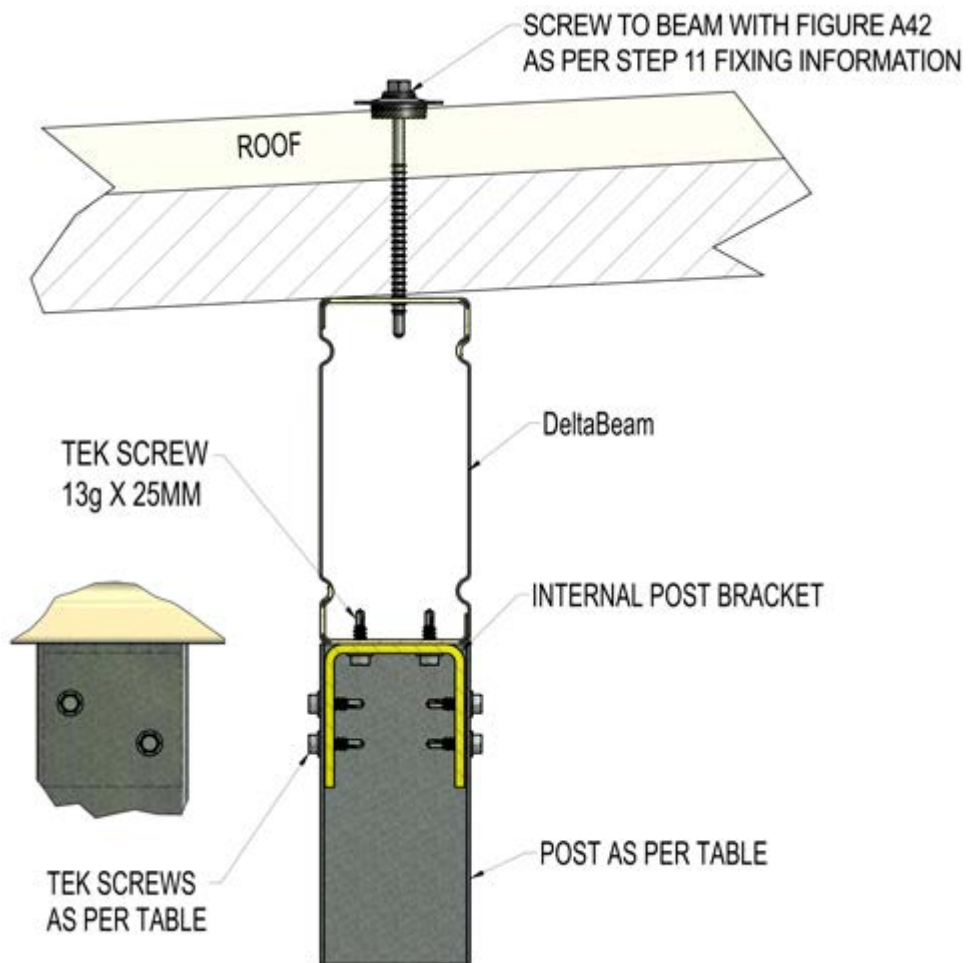

Figure A27

**Delta™ Steel or Aluminium Beam to Post (see Figure A28)**

Tabulated Data is in kN

**Fixing Details**

Post Size (mm)	Tek Screws 13g x 25mm (4off)	Tek Screws 13g x 25mm (8off)
65x65x1.6 Steel	4.68	7.8
65x65x1.6 Aluminium	3.76	7.53

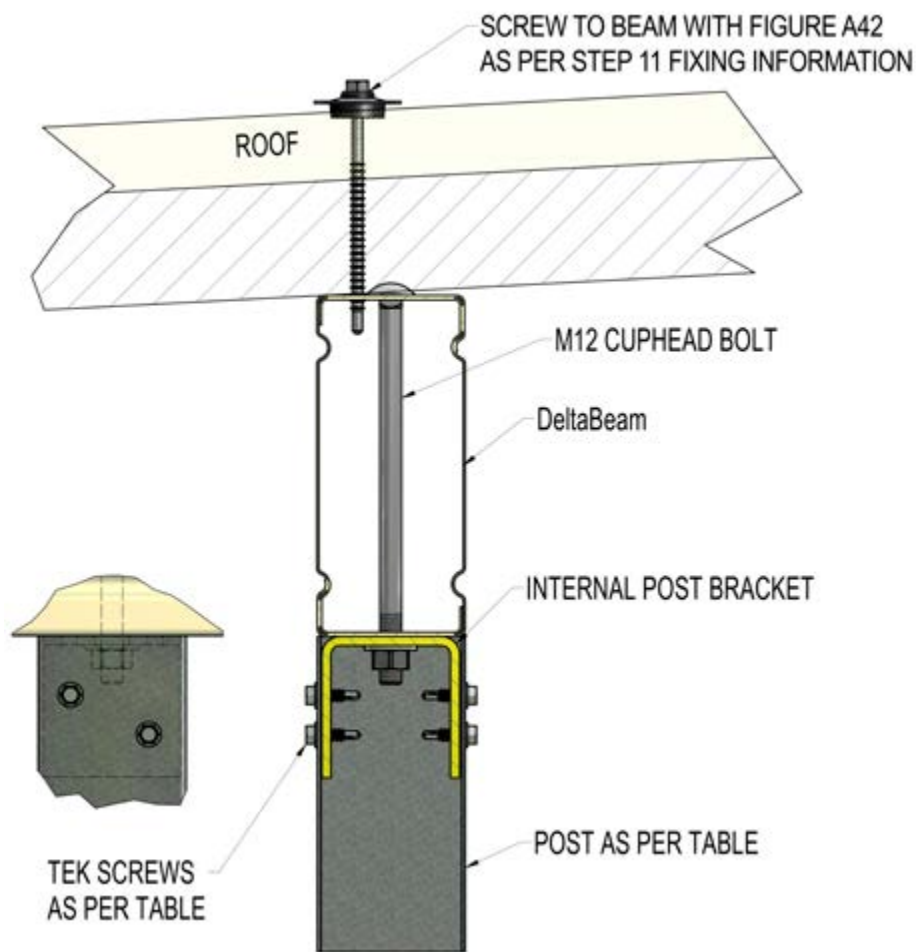

Figure A28

**Delta™ Steel or Aluminium Beam to Post (see Figure A29)**

Tabulated Data is in kN

Fixing Details		
Post Size (mm)	Cross Bolt - M10	Cross Bolt - M12
65x65x1.6 Steel	3.6	3.6
65x65x1.6 Aluminium	3.4	3.6

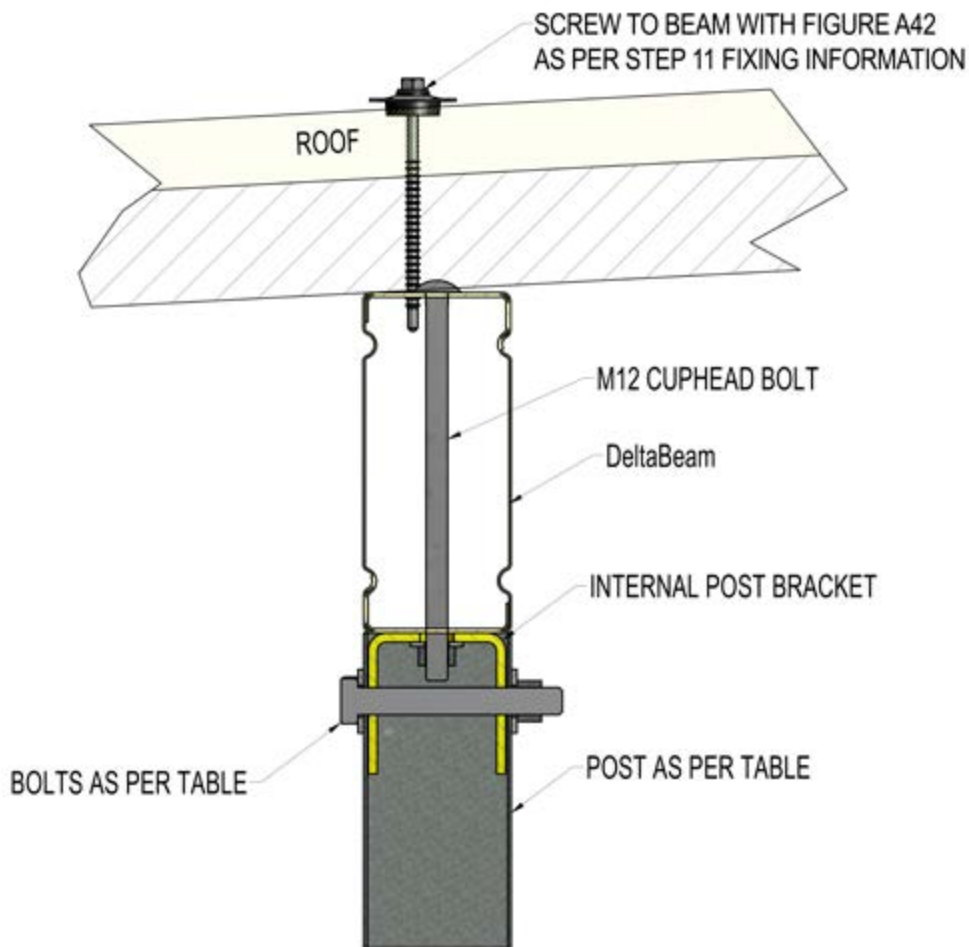

Figure A29

**Roofing to Timber Fascia (see Figure A30)**

Uplift Capacity of Receiver Channel to Rafter Connection (kN/m)

Rafter/Truss Connection Spacing mm	Strengthened Rafter
600	3
900	2
1200	1.5

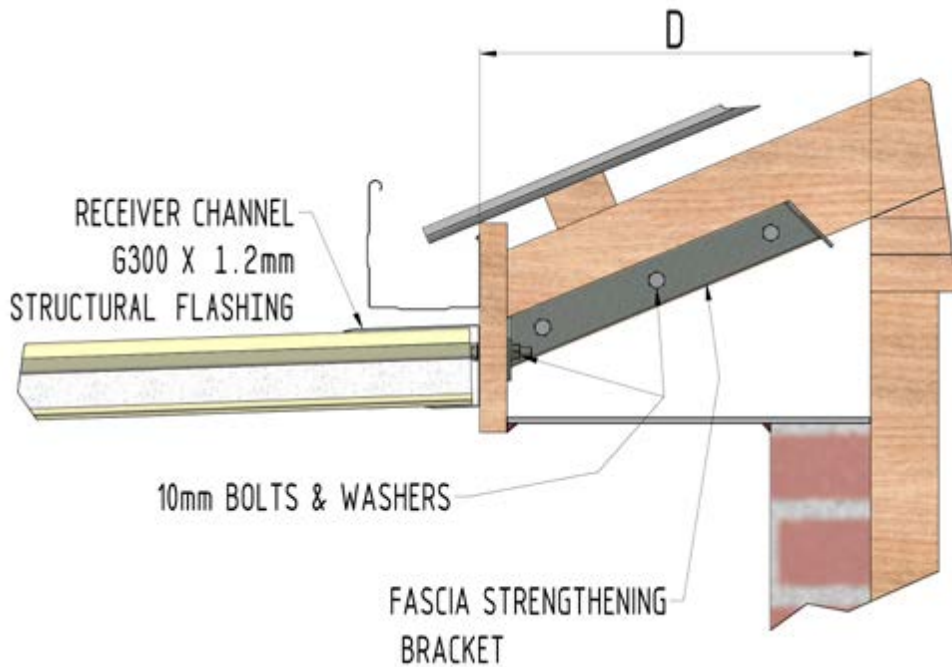

Figure A30

**Rafter Strengthening:**

D = 750mm maximum

Fix timber stiffener -

90 x 35 x 1500 long to rafter with  
75mm long x No.14 Type 17 batten screws @ 300  
centres (not shown above).

**Roofing to Metal Fascia (see Figure A31)**

Uplift Capacity of Receiver Channel to Rafter Connection (kN/m)

Rafter/Truss Connection Spacing mm	Strengthened Rafter
600	3
900	2
1200	1.5

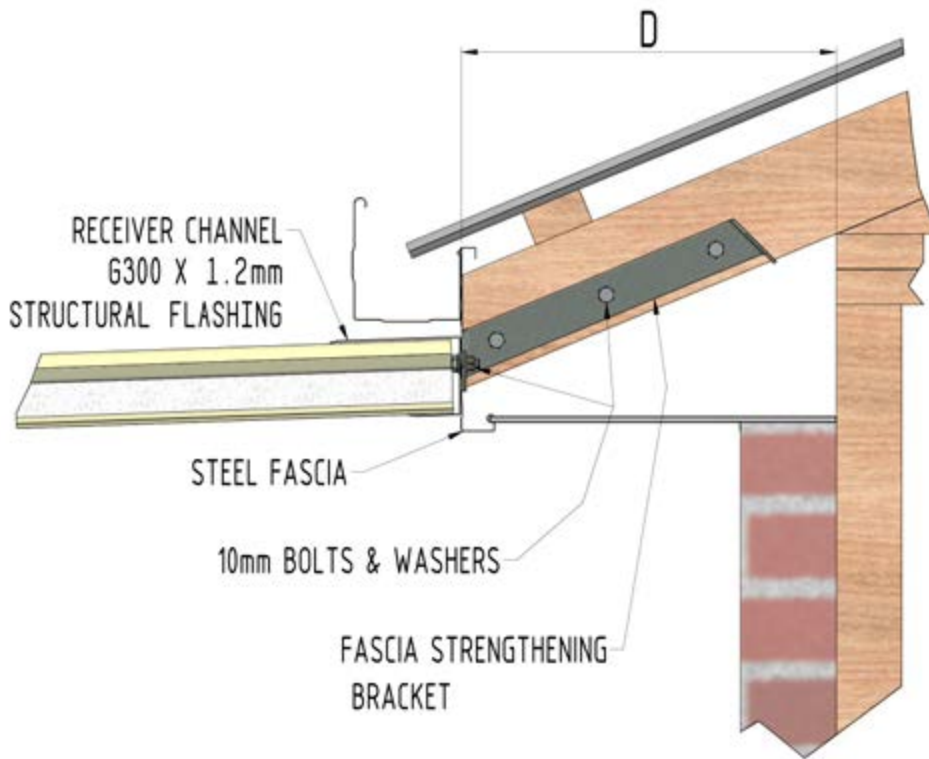

Figure A31

**Rafter Strengthening:**

D = 750mm maximum

Fix timber stiffener -

90 x 35 x 1500 long to rafter with  
75mm long x No.14 Type 17 batten screws @ 300  
centres (not shown above).

**Roofing to Timber Fascia with Bugle Head Screw (see Figure A32)**

Uplift Capacity of Receiver Channel to Rafter Connection (kN/m)

Rafter/Truss Connection Spacing mm	Strengthened Rafter
600	3
900	2
1200	1.5

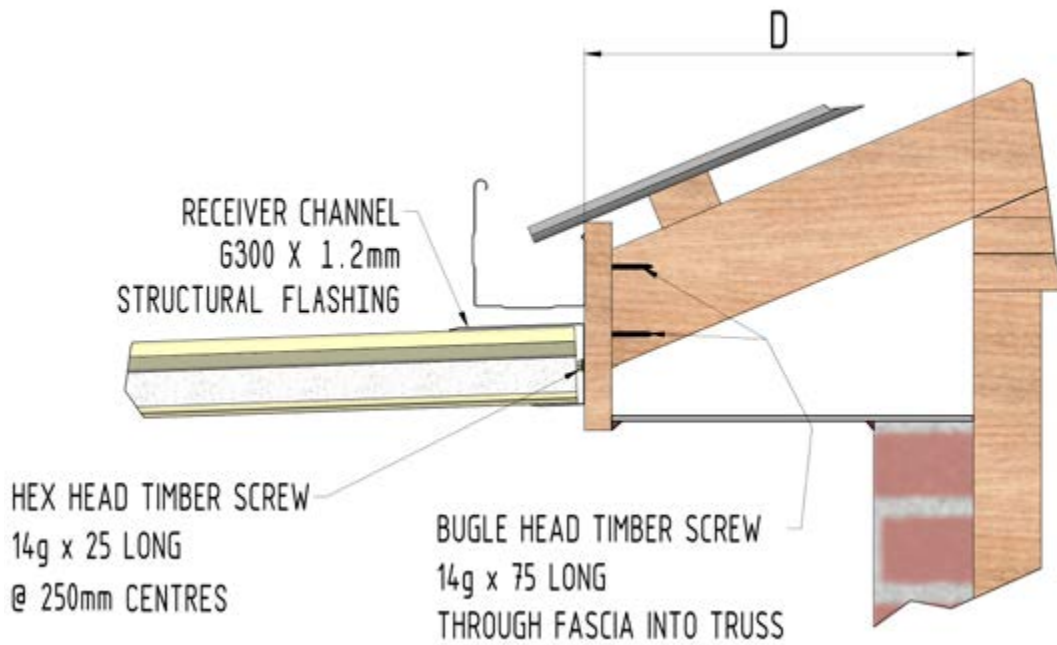

D = 750mm maximum

Figure A32

**Roofing to Masonry Wall (see Figure A33)**

Uplift Capacity of Receiver Channel to Masonry Wall (kN/m)

6mm Shuredrive @ 300mm centres	3.5
6mm Shuredrive @ 200mm centres	3.5
8mm Dynabolts @ 400mm centres	3.5

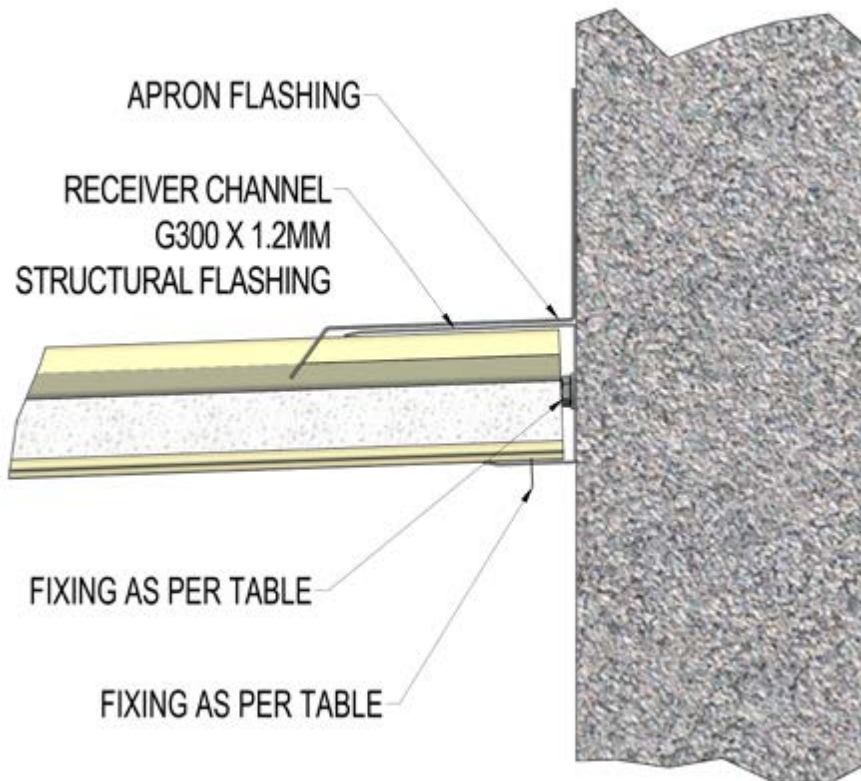

Figure A33



**Roofing to Blockwork Wall (see Figure A34)**

Uplift Capacity of Receiver Channel to Masonary Wall (kN/m)

6mm Shuredrive @ 300mm centres	2.5
6mm Shuredrive @ 200mm centres	2.5

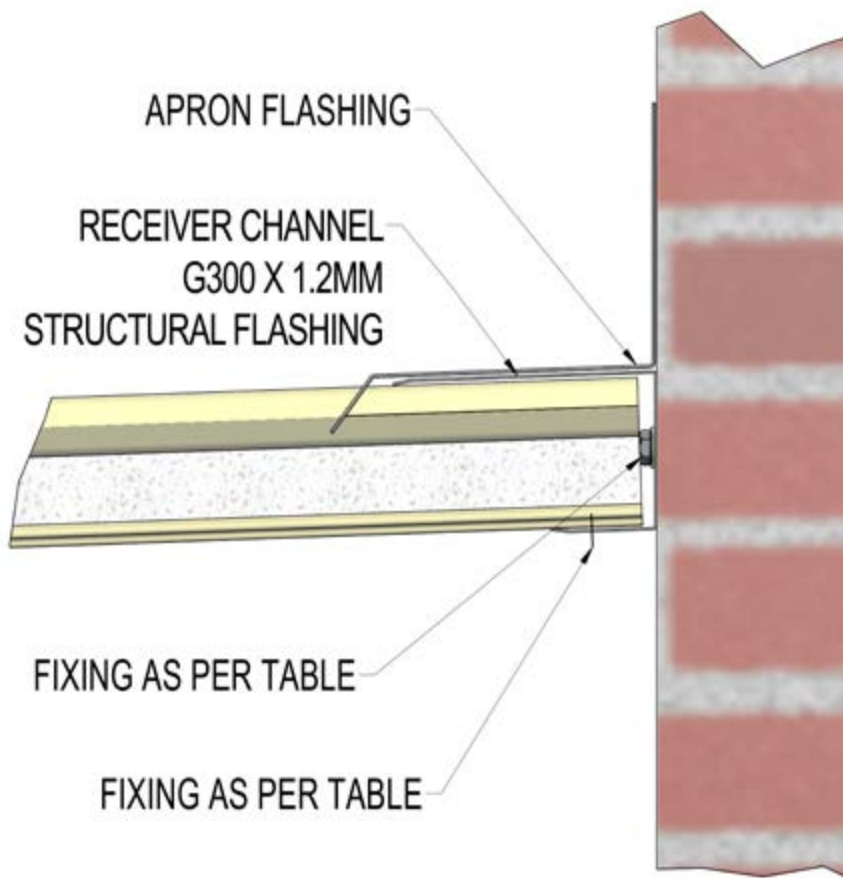

Figure A34

**Flyover with Extenda Bracket (see Figure A35)**

Parts List

ITEM	QTY	PART NUMBER	DESCRIPTION	ITEM	QTY	PART NUMBER	DESCRIPTION
1	1	DPB1002 2.5M	DELTABEAM™	4	2	ROOFEXTENDA	S500
2	4	DPP5736	BEAM SPACER	5	2	TIMBER TRUSS	TIMBER TRUSS
3	2	HEX BOLT M10 x 90	HEX BOLT M10 x 90 + NUT				

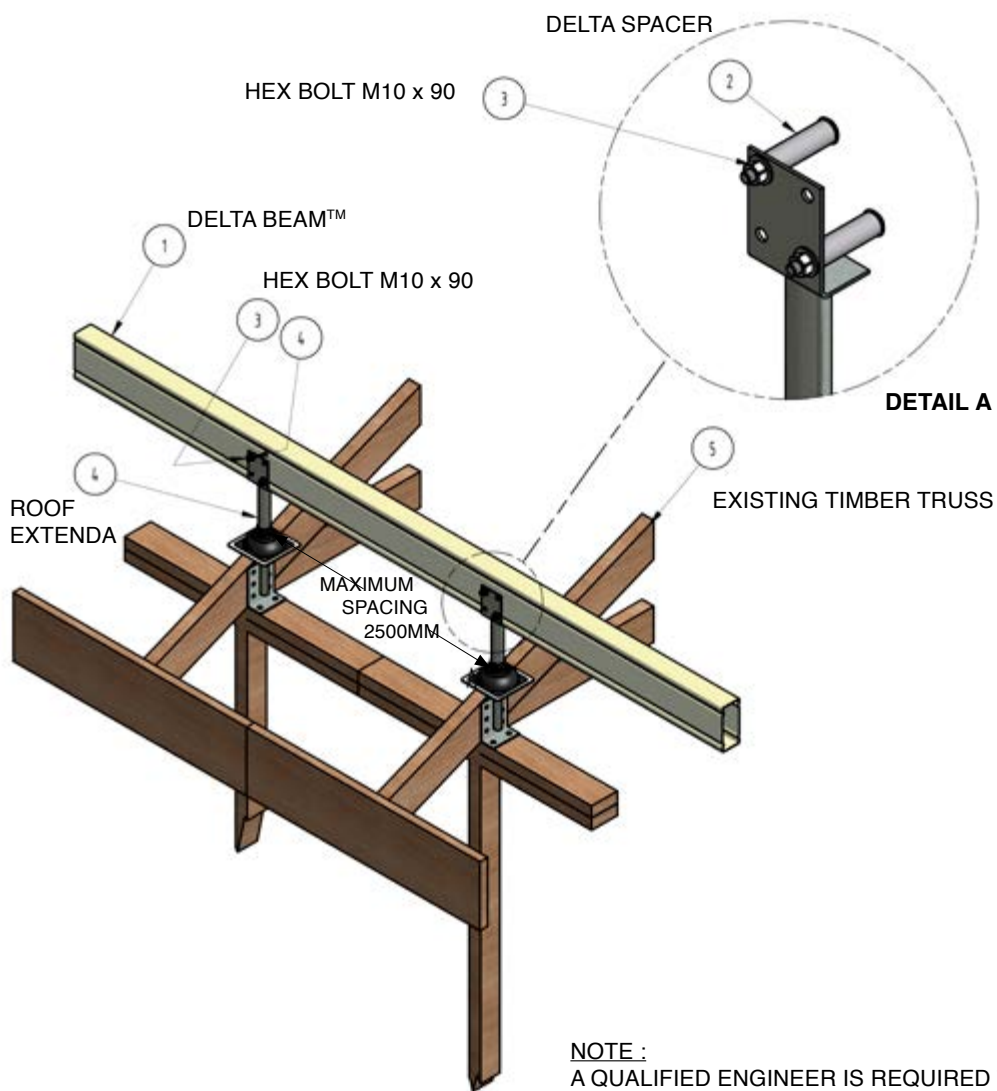

Figure A35

**Flyover with Delta Extension Bracket (see Figure A36)**

Parts List

ITEM	QTY	PART NUMBER	DESCRIPTION	ITEM	QTY	PART NUMBER	DESCRIPTION
1	1	DELTABEAM	DELTABEAM™	4	2	DPP1231	DELTA EXTENSION BRACKET
2	4	DPP5736	BEAM SPACER	5	4	EXISTING TIMBER TRUSS	EXISTING TIMBER TRUSS
3	4	HEX BOLT M10 X 90 + NUT	HEX BOLT M10 X 90 + NUT	6	2	WEATHERPROOF BOOT	WEATHERPROOF BOOT

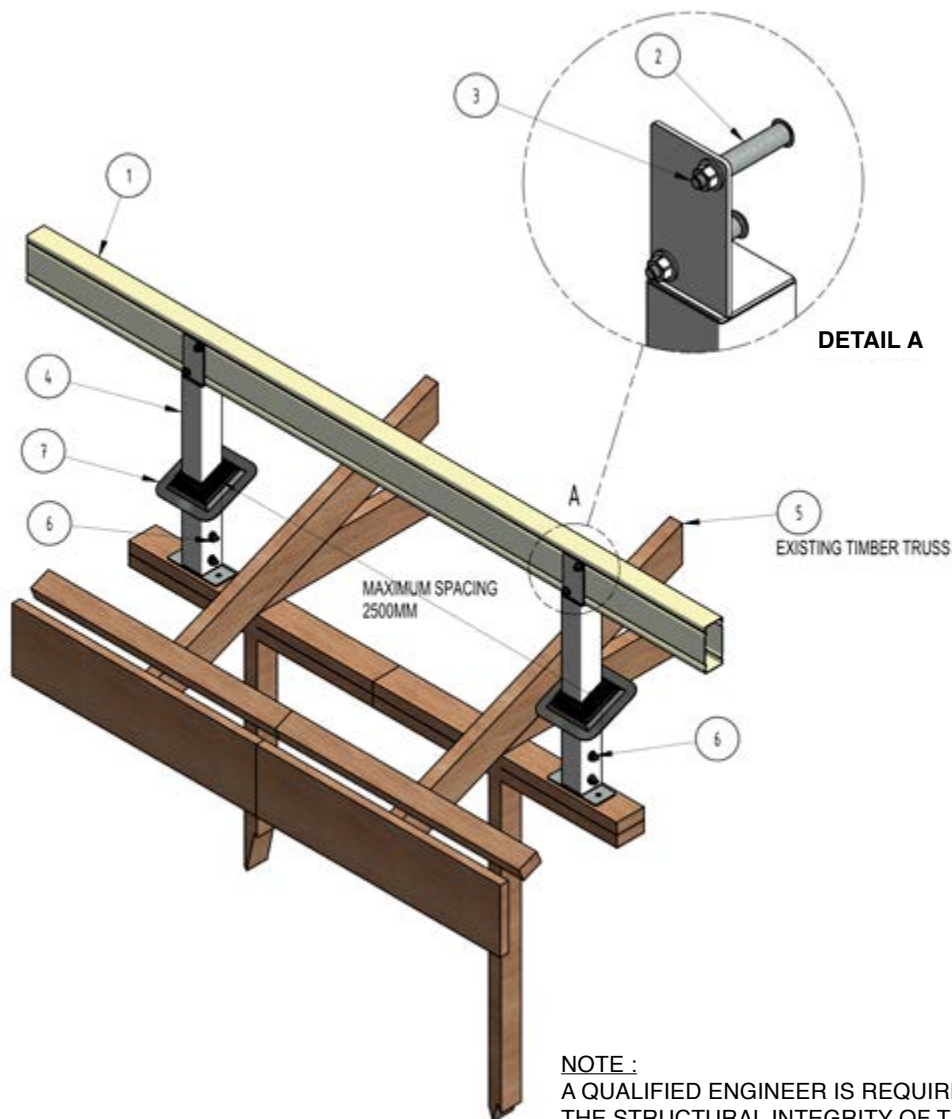

Figure A36

**Flyover with SHS Upright (See Figure A37)**

Part List

ITEM	QTY	PART NUMBER	DESCRIPTION	ITEM	QTY	PART NUMBER	DESCRIPTION
1	2	65x65x1.6 SHS	FLYOVER UPRIGHT SHS	6	4	DPP5736	BEAM SPACER
2	8	90064A580	TEK SCREW (SDS) 12-14x20	7	6	HEX BOLT M10x90	HEX BOLT M10x90 + NUT
3	1	DPB1002 2.5m	DELTABEAM	8	6	HEXBOLT_STEEL_DIN931_	HEX-HEAD BOLT M10x70 + NUT
4	2	DPP1226-X	ADJUSTABLE FASCIA BRACKET	9	2	TIMBER TRUSS WALL	TIMBER TRUSS WALL
5	2	DPP5706-P	INTERNAL POST BRACKET (SUIT 65x65x1.6)				

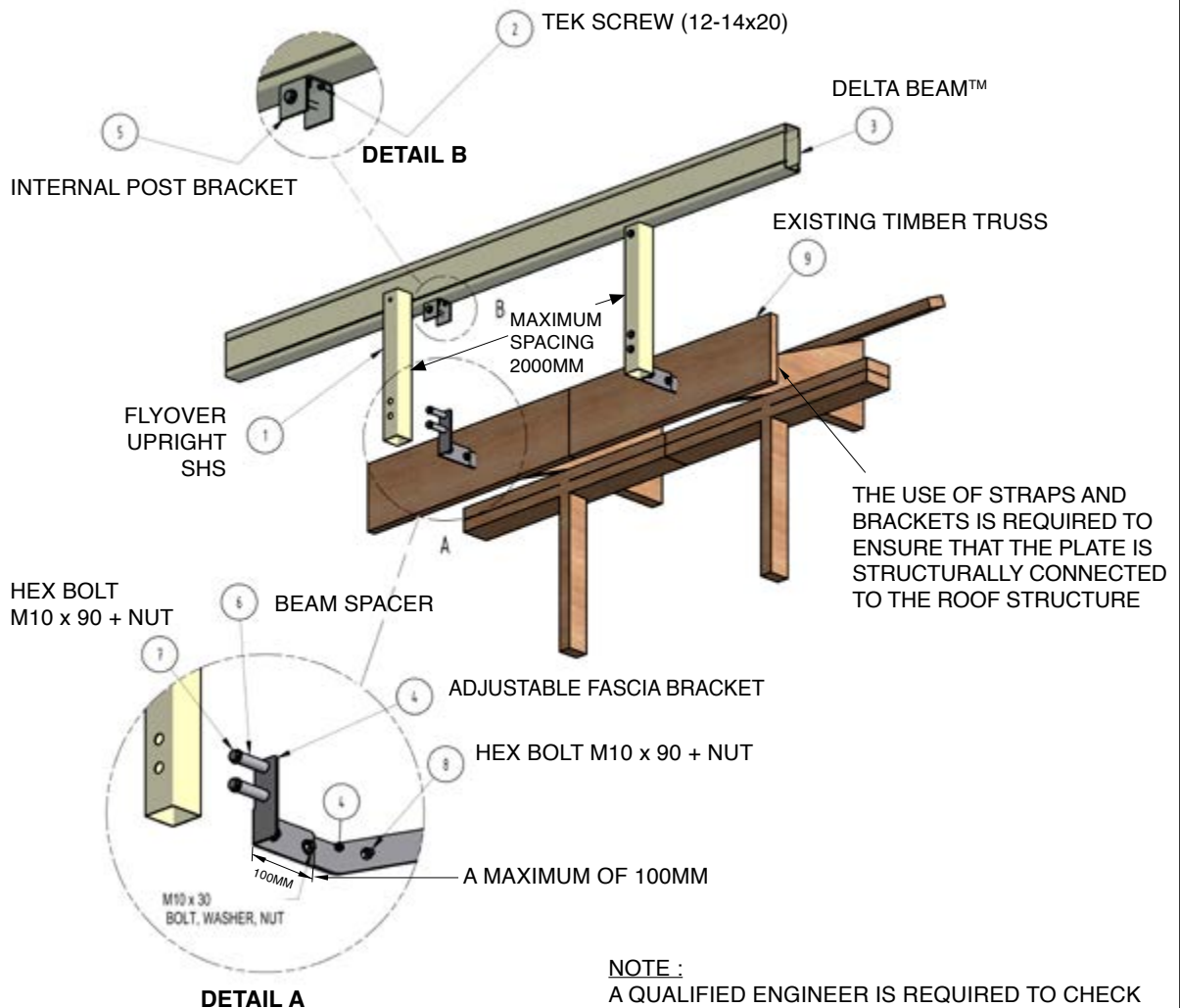
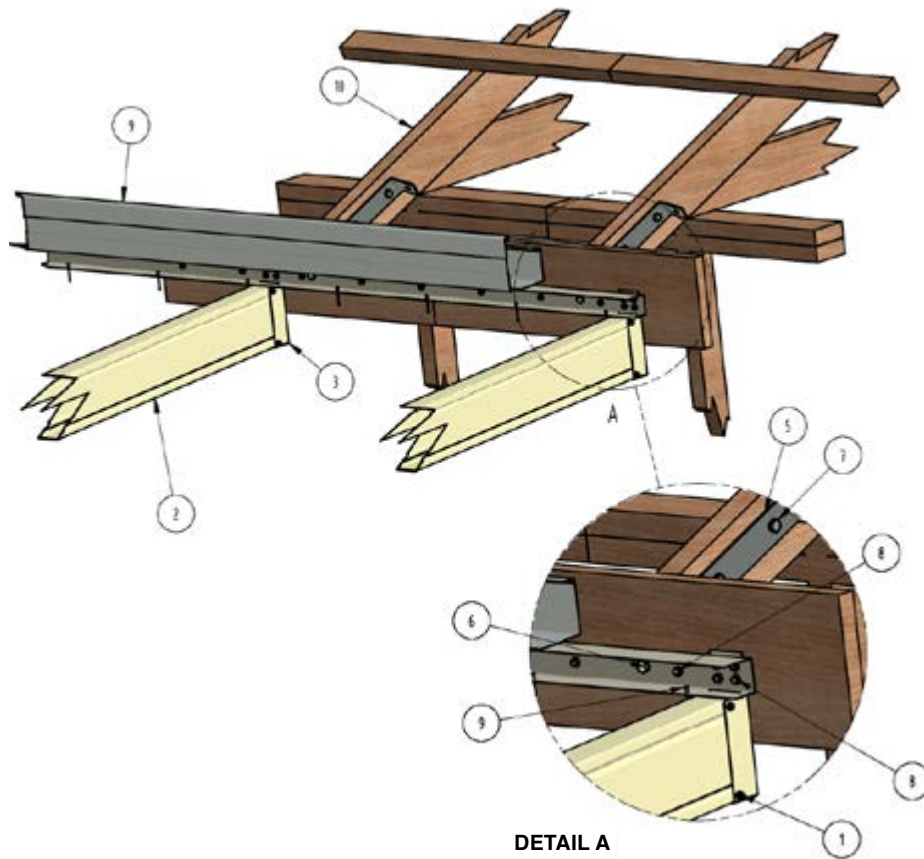

Figure A37

**Beam to Timber Fascia Connection (See Figure A38)**

Part List

ITEM	QTY	PART NUMBER	DESCRIPTION	ITEM	QTY	PART NUMBER	DESCRIPTION
1	8	90064A580	TEK SCREW (SDS) 12-14X20	6	2	HEX HEAD-M10X60 +NUT	HEX-HEAD BOLT M10X60 + NUT
2	2	DPB1002 2.5M	DELTABEAM	7	6	HEXBOLT_STEEL_DIN931_DIN931	HEX-HEAD BOLT M10X70 + NUT
3	2	DPB5017-H	FASCIA HANGING BRACKET	8	16	SCREW T17-12X25	SCREW T17-12X25
4	1	DPC5315-3M	RECEIVER CHANNEL	9	1	GUTTER	GUTTER
5	2	DPP5711	FACIA STRENGTHENING BRACKET + M10 WASHERS	10	2	TIMBER TRUSS WALL	TIMBER TRUSS WALL



**NOTE :**  
 A QUALIFIED ENGINEER IS REQUIRED TO CHECK THE STRUCTURAL INTEGRITY OF THE EXISTING ROOFING AND WALL SYSTEM.

Figure A38

**Beam to Steel Fascia Connection (See Figure A39)**

Part List

ITEM	QTY	PART NUMBER	DESCRIPTION	ITEM	QTY	PART NUMBER	DESCRIPTION
1	8	90064A580	TEK SCREW (SDS) 12-14X20	6	2	HHB-M10X25	HEX-HEAD BOLT M10X25
2	2	DPB1002 2.5M	DELTABEAM	7	6	HEXBOLT_STEEL_DIN931_DIN931	HEX-HEAD BOLT M10X70
3	2	DPB5017-H	FASCIA HANGING BRACKET	8	1	GUTTER	GUTTER
4	1	DPC5315-3M	DELTASINGLE - RECEIVER CHANNEL	9	16	TEK SCREW 10-16X16	TEK SCREW (SDS) 10-16X16
5	2	DPP5711	FACIA STRENGTHENING BRACKET + M10 WASHERS	10	2	TIMBER TRUSS WALL_STEEL FASCIA	TIMBER TRUSS WALL_STEEL FASCIA

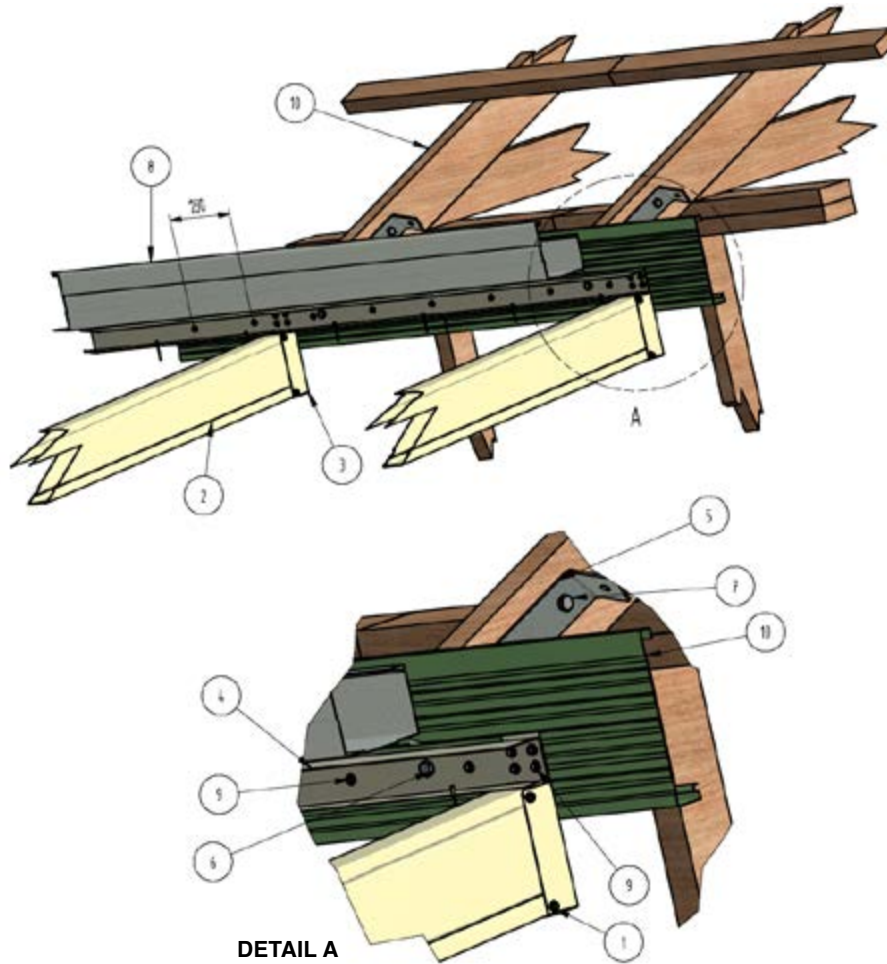

**NOTE :**  
 A QUALIFIED ENGINEER IS REQUIRED TO CHECK THE STRUCTURAL INTEGRITY OF THE EXISTING ROOFING AND WALL SYSTEM.

Figure A39

**Through Fascia Beam (See Figure A40)**

Part List

ITEM	QTY	PART NUMBER	DESCRIPTION	ITEM	QTY	PART NUMBER	DESCRIPTION
1	24	90064A580	TEK SCREW (SDS) 12-14X20	6	6	DPP5736	BEAM SPACER
2	1	DPB1001 2.5M	DELTABEAM	7	9	HEXBOLT_STEEL_DIN931_	HEX-HEAD BOLT M10X70 + NUT
3	3	DPB1002 - 300	DELTABEAM	8	6	M10 CUP HEAD X 90	M10 CUP HEAD X 90 + NUT
4	3	DPB5017	BEAM END CAP	9	3	TIMBER TRUSS WALL	TIMBER TRUSS WALL
5	3	DPP1226-X	ADJUSTABLE FASCIA BRACKET				

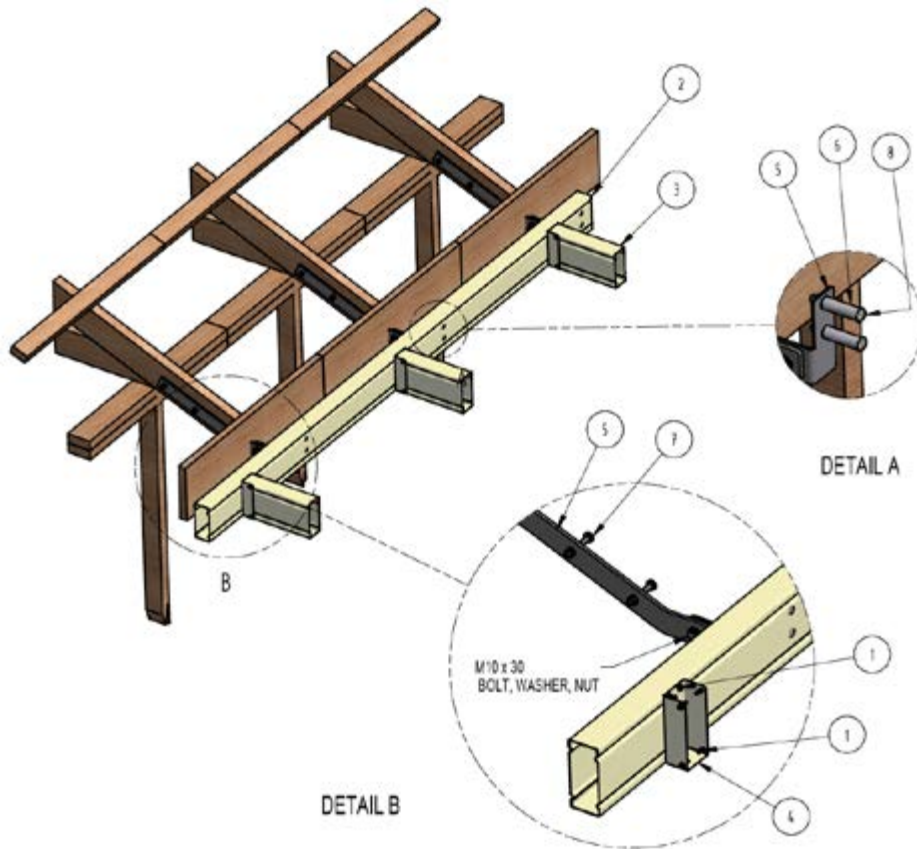

**NOTE :**  
 A QUALIFIED ENGINEER IS REQUIRED TO CHECK THE STRUCTURAL INTEGRITY OF THE EXISTING ROOFING AND WALL SYSTEM.

Figure A40

**Adjustable Fascia Bracket (See Figure A41)**

Part List

ITEM	QTY	PART NUMBER	DESCRIPTION
1	1	DPP5717	ADJUSTABLE FASCIA BRACKET MAIN
2	1	DPP5718	ADJUSTABLE FASCIA BRACKET END
3	2	M10_NUT_ASSY	M10 NUT w FLAT WASHER & SPRING WASHER
4	2	M10x30_ASSY	M10 HEX HEAD 8.8 30mm AND WASHER

**Adjustable Fascia Bracket**

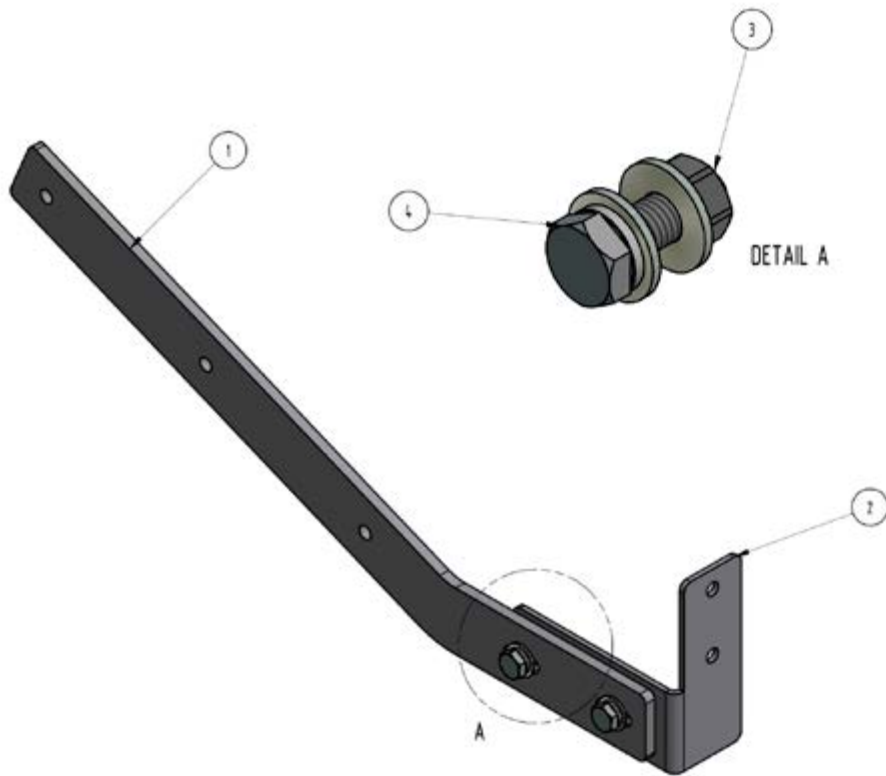

Figure A41



**Steel Inline Beam Joiner (See Figure A42)**

Part List

ITEM	QTY	PART NUMBER	DESCRIPTION
1	32	90064A580	TEK SCREW (SDS) 12-14X20
2	4	DPB1002 - Length	DELTA STEEL BEAM
3	1	DPB5020	INLINE BEAM JOINER OVER POST

**Inline Beam Joiner**

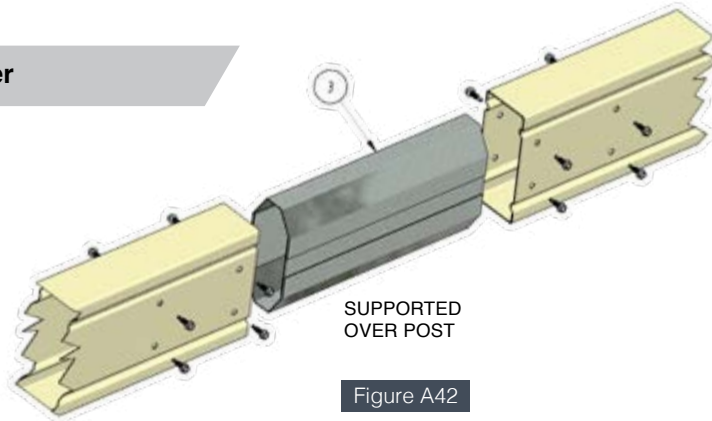

Figure A42

**Steel Post End Cap Connection (See Figure A43 & A44)**

Part List

ITEM	PART NUMBER	DESCRIPTION	ITEM	PART NUMBER	DESCRIPTION
1	DPB1002 LENGTH	DELTA STEEL BEAM	1	DPB1002 LENGTH	DELTA STEEL BEAM
2	DPP2169	100MM X 2MM STEEL POST	2	DPP2166	65MM X 1.6MM STEEL POST
3	M10 X 120 BOLTS NUTS & WASHERS	M10 X 120 BOLTS NUTS & WASHERS	3	DPP5736	DELTABEAM SPACER
4	DPP5736	DELTABEAM SPACERS	4	M10 X 90 BOLTS & WASHERS	M10 X 90 BOLTS & WASHERS
5	DPB5017	DELTA BEAM STEEL END CAPS	5	DPB5017	DELTABEAM STEEL END CAP

**100mm Post End Cap Connection**

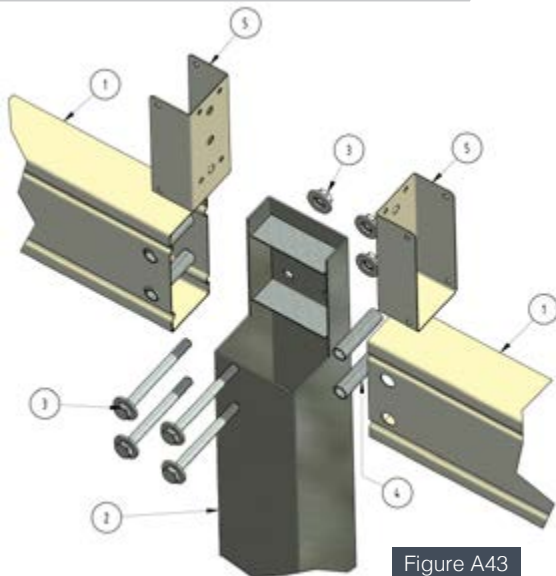

Figure A43

**65mm Post End Cap Connection**

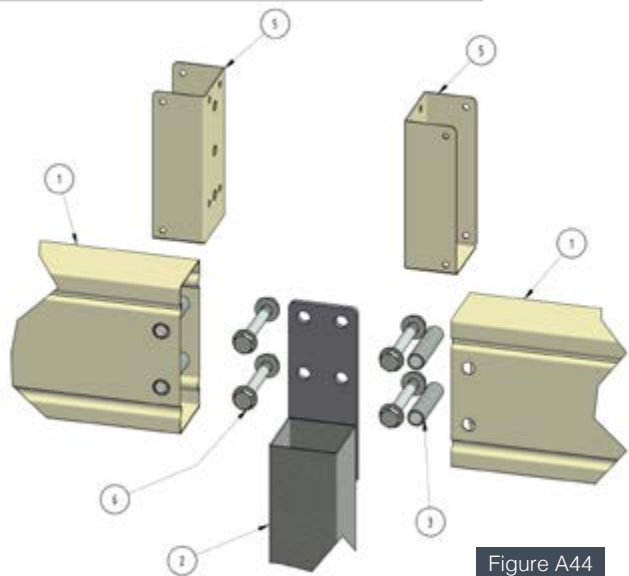

Figure A44

**Steel Beam to Beam Connection (See Figure A45)**

Part List

ITEM	QTY	PART NUMBER	DESCRIPTION
1	16	90064A580	TEK SCREW (SDS) 12-14X20
2	3	DPB1002 LENGHT	DELTA STEEL BEAM
3	2	DPB5017	DELTA STEEL BEAM TO BEAM BRACKET

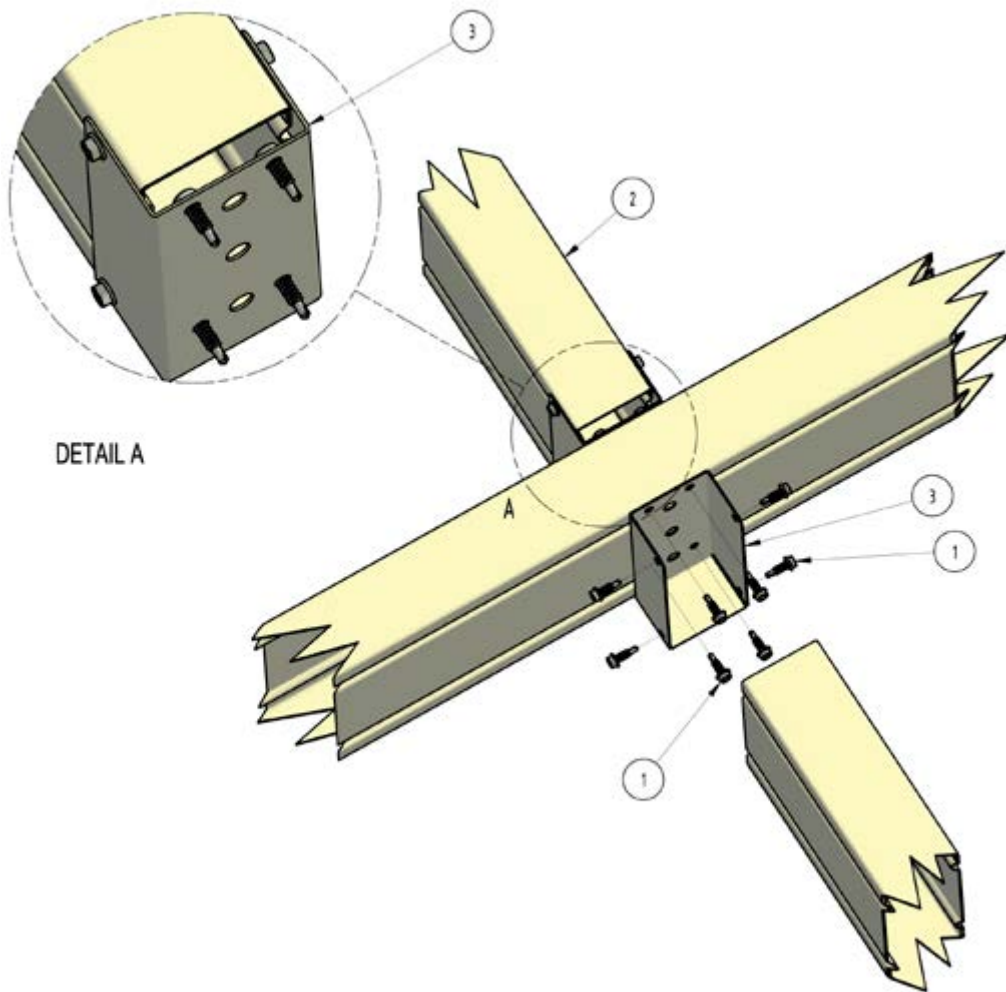

Figure A45

**Aluminium Post End Cap Connection (See Figure A46)**

Part List

ITEM	PART NUMBER	DESCRIPTION
1	POST-10003	100MM X 3MM ALUMINIUM POST
2	M10 X 120 BOLTS NUTS & WASHERS	M10 X 120 BOLTS NUTS & WASHERS
3	EXBEAM LENGTH	DELTA ALUMINIUM BEAM
4	ENDCAPSTR	ALUMINIUM STRUCTURAL END CAP

**100mm Post End Cap Connection**

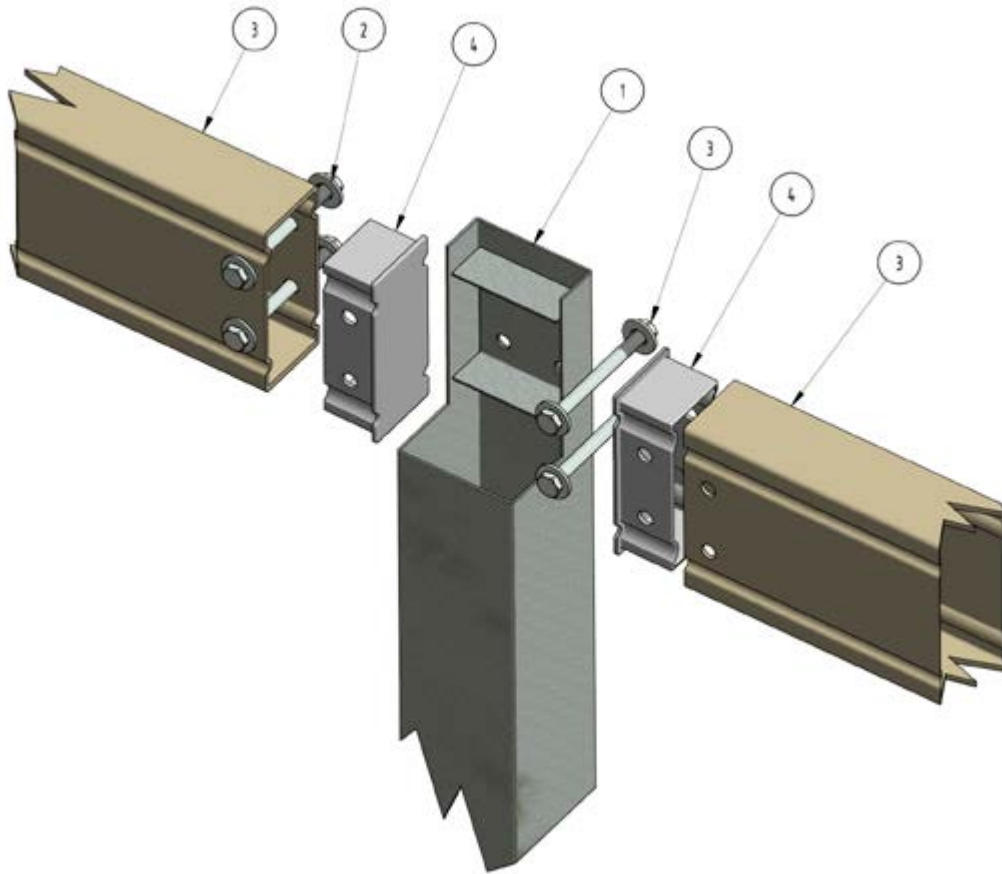

Figure A46

**Aluminium Beam to Beam Joiner (See Figure A47)**

Part List

ITEM	PART NUMBER	DESCRIPTION
1	EXBEAM	DELTA ALUMINIUM BEAM
2	ENDCAPSTR	ALUMINIUM STRUCTURAL END CAP
3	M10 X 100	M10 X 100 BOLT AND WASHER
4	M10 NUT	M10 NUT AND WASHER
5	90064A580	TEK SCREW (SDS) 12-14X20

**Beam to Beam Connection**

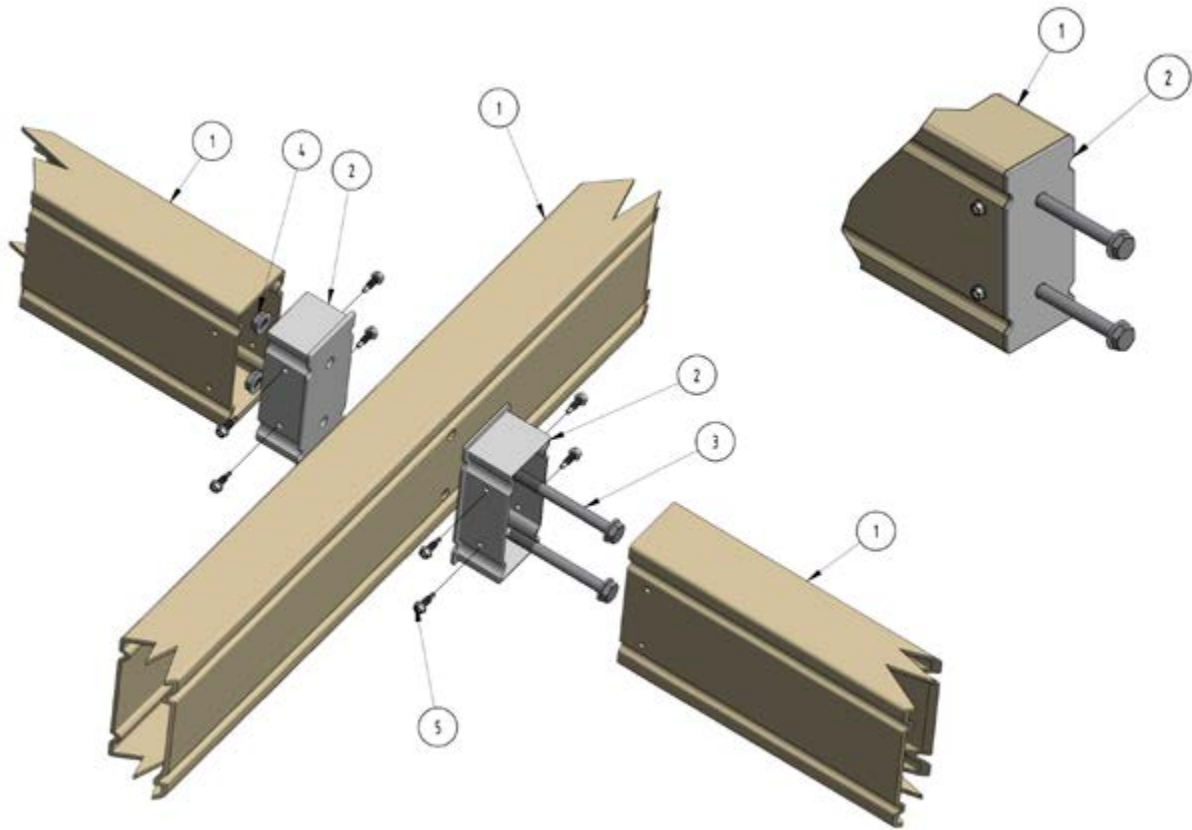

Figure A47



Select the number of fixings and type required.

### Number of Fixings:

DeltaTrim™, DeltaTrimTrim™ & DeltaTrimCorro™	
Wind Category	No. of fixings required
N1-N4	1 x Screw with Neo Washer & Cyclone Plate per Crest
C1-C2, N5	1 x Screw with Neo Washer & Cyclone Plate per Crest + 1 x Screw with Embossed Washer per Pan
C3-C4	1 x Screw with Neo Washer & Cyclone Plate per Crest + 2 x Screw with Embossed Washer per Pan

DeltaOrb™	
Wind Category	No. of fixings required
N1-N4, C1	1 x Screw with Neo Washer & Cyclone Plate per every second (2nd) Crest
C2-C4, N5	1 x Screw with Neo Washer & Cyclone Plate per Crest + 1 x Screw with Embossed Washer per Pan

DeltaCorroCorro™	
Wind Category	No. of fixings required
N1-N4, C1	1 x Screw with Neo Washer & Cyclone Plate per every second (2nd) Crest
C2-C4, N5	1 x Screw with Neo Washer & Cyclone Plate per Crest + 1 x Screw with Embossed Washer per Pan

### Spacings for Secondary Fixings:

Top-Skin Overlap - DeltaTrim™, DeltaOrb™, DeltaCorroCorro™, DeltaTrimTrim™ & DeltaTrimCorro™	
Stitching Spacings	No. of fixings required
300mm centres	1 x M13 x 25mm Tek Screw with Neo Washer

Flashings & Rainwater Goods	
Fixing Spacings	No. of fixings required
300mm centres	For G300 1.2mm Structural Flashings : - 1 x M13 x 25mm Tek Screw with Neo Washer
400mm centres	For G300 0.55mm Flashings : - 1 x Dome Rivet 73 AS 4.3, or 1 x M10 x 16mm Tek Screw with Neo Washer



Select the number of fixings and type required.

### Screw Types

#### Main Fasteners with Cyclone Plate and Washer

Metal Tek - Fixing | Fixing into Steel Beams up to 12.5mm

Figure A48



T17 - Fixing | Fixing into Timber Beams

Figure A49



#### Secondary Fasteners

Tek M13 x 25mm



Figure A50

Tek M10 x 16mm



Figure A51

Dome Rivet 73 AS 4.3

Figure A52





Select the number of fixings and type required.

**Screw Selection Tables**

DeltaTrim™					
Minimum Class 3 - must be HEX Head	Steel Beam	Timber Beam	Minimum Class 3 - must be HEX Head	Steel Beam	Timber Beam
50mm	135mm	125mm	150mm	230mm	230mm
75mm	150mm	150mm	175mm	260mm	265mm
100mm	175mm	175mm	200mm	260mm	300mm
125mm	200mm	200mm			

DeltaOrb™					
Minimum Class 3 - must be HEX Head	Steel Beam	Timber Beam	Minimum Class 3 - must be HEX Head	Steel Beam	Timber Beam
50mm	115mm	125mm	150mm	200mm	230mm
75mm	135mm	150mm	175mm	230mm	265mm
100mm	150mm	175mm	200mm	260mm	300mm
125mm	175mm	200mm			

DeltaCorroCorro™					
Minimum Class 3 - must be HEX Head	Steel Beam	Timber Beam	Minimum Class 3 - must be HEX Head	Steel Beam	Timber Beam
75mm	115mm	125mm	175mm	200mm	230mm
100mm	135mm	150mm	200mm	230mm	265mm
125mm	150mm	175mm	225mm	260mm	265mm
150mm	175mm	200mm	250mm	300mm	300mm

DeltaTrimTrim™					
Minimum Class 3 - must be HEX Head	Steel Beam	Timber Beam	Minimum Class 3 - must be HEX Head	Steel Beam	Timber Beam
75mm	200mm	200mm	150mm	260mm	265mm
100mm	230mm	230mm	175mm	300mm	300mm
125mm	230mm	230mm	200mm	300mm	300mm

DeltaTrimCorro™					
Minimum Class 3 - must be HEX Head	Steel Beam	Timber Beam	Minimum Class 3 - must be HEX Head	Steel Beam	Timber Beam
75mm	175mm	175mm	150mm	260mm	265mm
100mm	200mm	200mm	175mm	300mm	300mm
125mm	230mm	230mm	200mm	300mm	300mm



Delta Panels™ Pty Ltd is committed to an ongoing programme of product research and development and reserves the right to update and amend information without prior notice. Reasonable care has been taken to ensure that all published information is correct and accurately reflects the properties of our products and their design applications at the time of publication. However these are a general guide only, it is the customers responsibility to ensure that all products and their stated applications are fit for purpose and complies with all relevant statutory requirements. To ensure that you keep abreast of all updates in our product range, all current reference material are available on our web page for downloading.

All information contained within this document is subject to Copyright and may not be copied without the express permission of Delta Panels™ Pty Ltd.

Delta Panels™, DeltaSpan™, DeltaTrim™, DeltaOrb™, DeltaCorroCorro™, DeltaTrimTrim™, DeltaTrimCorro™, DeltaLowProfile™, DeltaPanelLight™ & DeltaDualCore™ are registered trademarks of Delta Panels™ Pty Ltd.