



DeltaDualCore™ Panel Class 10a Awning and Patio Roof Systems

Fire Engineering Report

Revision 1-11

Report Issue Authorisation

Project Title DeltaDualCore™ Panel Class 10a Awning and Patio Systems

File Name A21007 J001 - DeltaDualCore Panel Awnings FER mt rev 1-11

SOTERA

Unit 413, 21 Sunshine
Parade, Miami QLD
4220











225 Wickham Terrace
Spring Hill Q 4000







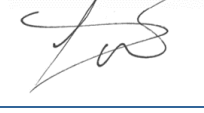
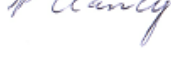



p: +61 7 5562 0022
f: +61 7 5562 1466
sotera@sotera.com.au
www.sotera.com.au

Accreditations:

National Professional Engineers Register, Australia: Fire and Structures No 136936
Accredited Fire Safety Engineers, Qld, RPEQ 10045
Accredited Fire Safety Engineers, NSW, Department of Planning . No: BPB0210
Accredited Fire Safety Engineers. Victoria, Building Control Commission, RBP No.
EF 30459

Revision/verification history

Rev	Date	Purpose of issue	Author	Checked, Authorised
1-11	24/09/2024	FER	Margaret Tatum 	Dr Paul Clancy 
1-10	17/01/2023	FER	Jacob Sherwin 	Dr Paul Clancy 
1-9	01/09/2021	FER	Dirk van der Walt 	Dr Paul Clancy 
1-8	17/08/2021	FER	Dirk van der Walt 	Dr Paul Clancy 
1-7	02/08/2021	FER	Dirk van der Walt 	Dr Paul Clancy 
1-6	21/07/2021	FER	Dirk van der Walt	Dr Paul Clancy 

Rev	Date	Purpose of issue	Author	Checked, Authorised
				
1-5	21/05/2021	FER	Dirk van der Walt 	Dr Paul Clancy 
1-4	12/05/2021	FER	Dirk van der Walt 	Dr Paul Clancy 
1-3	05/03/2021	FER	Dirk van der Walt 	Dr Paul Clancy 
1-2	04/03/2021	FER	Dirk van der Walt 	Dr Paul Clancy 
1-1	03/03/2021	FER	Dirk van der Walt 	Dr Paul Clancy 
1-0	26/02/2021	FER	Dirk van der Walt 	Dr Paul Clancy 

This report shall not be reproduced in part or in full without the written consent of a director of SOTERA.

Contents

1	Summary	6
1.1	General	6
1.2	Brief Description of Application	6
1.3	Fire Safety Systems	6
1.4	Variations to DtS Provisions and Performance Requirements	7
2	Scope and Limitations	8
2.1	General	8
2.2	Summary of Developments in Fire Engineering Report	8
2.3	Scope of Project.	10
2.4	Supporting Information	10
2.5	Stakeholders	11
2.6	Limitations	12
3	DeltaDualCore™ System	13
3.1	Description of Application	13
3.2	Description of System	13
3.3	Fire Test Certificates	18
4	DeltaDualCore™ Awning or Patio within 900 mm of Site Boundary	22
4.1	Assessment Task Defined	22
4.2	Hazards	24
4.3	Performance to be Assessed	25
4.4	Systems	25
4.5	Methodology	26
4.6	Acceptability Criteria	27
4.7	Design Fires	27
4.8	Assessment	30
5	References	39
A.1	Introduction	40
A.2	Methodology	40
A.2	Results & Conclusion	41
B.1	Introduction	43
B.2	Model Geometry	43
B.3	Design Fire	44
B.4	Results & Conclusion	45
B.5	FDS Grid sensitivity	49
B.6	FDS Inputs	50
C.1	Mineral Wool AS1530.1 Test Certificate	51
C.2	Coated Sheet Steel (Low Carbon Steel) AS1530.1 Test Certificates	53
D.1	DeltaOrb™ Facings Applied to EPS-FR Core AS1530.3 Test Certificate	55
D.2	DeltaTrim™ Facings Bonded to EPS-FR Core AS1530.3 Test Certificate	57
D.3	Coated Sheet Steel (Zincalume 0.5mm) AS1530.3 Test Certificate	59
D.4	Coated Sheet Steel (Colorbond 0.8mm) AS1530.3 Test Certificate	60
D.5	Coated Sheet Steel (Colorbond 0.7mm) AS1530.3 Test Certificate	61

D.6	Coated Sheet Steel (MagnaFlow) AS1530.3 Test Certificate	62
D.7	Coated Sheet Steel (UniCote 0.55mm) AS1530.3 Test Certificate	64
D.8	Coated Sheet Steel (UniZinc) AS1530.3 Test Certificate	65
D.9	Coated Steel Facings Bonded to Mineral Wool Core AS1530.3 Test Certificate	67

1 Summary

1.1 General

SOTERA has been engaged to carry out fire engineering assessment of the proposed performance solution for the project:

Client:	Delta Panels Pty Ltd
Project Title:	DeltaDualCore™ Panel Awning Systems

This summary gives the proposed performance solution and BCA issues. The main body of the report provides the detailed documentary evidence justifying the performance solutions. To avoid errors in duplication material may not be repeated. The main body of the report must be read in conjunction with this summary.

1.2 Brief Description of Application

This fire engineering report is intended to assess the generic application of DeltaDualCore™ panel awning systems when used as a Class 10a structure (awning or patio) attached or adjacent to a Class 1a building positioned within 900 mm of a site boundary pursuant to NCC 2022 Housing Provision Standard & Volume 2.

1.3 Fire Safety Systems

(A) Performance solution systems:

1. This performance solution is solely applicable to the DeltaDualCore™ roofing system which may comprise either DeltaTrim™ or DeltaOrb™ dual core sandwich panels with a core consisting of Expanded Polystyrene with fire retardant (EPS-FR) and mineral wool composite (refer to Section 3), non-combustible supporting structure and non-combustible plumbing fixtures (gutters and downpipes).
2. All components used in the awning and patio construction shall be compliant with Section 3. The components shall not be modified except with the written authorisation of the manufacturer and SOTERA.
3. The following restrictions apply for the Class 10a awning and patio installation:
 - (a) Two or more sides (making up at least one third of the awning or patio perimeter) shall be “open”; that is the roof covering shall be more than 500 mm from another building or allotment boundary on at least two sides without enclosing these sides with a wall, privacy screen or the like within 500mm of the edge of the roof covering. A boundary along a road or public space such as parklands, lakes, rivers and the like (where the construction of buildings is unlikely) may be considered open regardless of proximity to the boundary subject to no vertical obstruction (wall, privacy screen or the like) within 500 mm of the edge of the roof covering.
 - (b) The awning or patio structure shall not provide direct vertical support to any part of the adjacent Class 1 building.
 - (c) The portion of the awning system which is located within 900 mm of a site boundary shall consist solely of non-combustible components (subject to (d)) including:
 - (i) Mineral wool
 - (ii) Pre-finished steel sheeting with combustible surface finish not exceeding 1 mm thickness and with a spread of flame index no greater than 0 in accordance with NCC H3D2(1)(e).
 - (iii) Steel fixtures, gutters and the like
 - (iv) Steel columns, beams, purlins and the like

- (v) Metallic flashing
- (d) As the DeltaDualCore panel constitutes a bonded laminate, the following restrictions shall apply to the portion of the panel that is within 900mm of the site boundary:
 - (i) The lamina's shall be restricted to steel facings with mineral wool core, each of which has been tested to AS1530.1 and are deemed non-combustible (refer to AS1530.1 fire test certificates in Section Appendix A).
 - (ii) Each adhesive layer may not exceed 1 mm in thickness and the total combined thickness of adhesive layers may not exceed 2 mm (refer to Section Appendix E which confirms adhesive layer thicknesses are within the required limits).
 - (iii) The spread of flame index and the smoke developed index of the bonded laminated material as a whole shall not exceed 0 and 3 respectively (refer to AS1530.3 test certificates given in Section Appendix D).
 - (iv) Only the portion of each DeltaDualCore™ panel containing a mineral wool core shall comply with items i) to iii) in accordance with NCC H3D2(1)(g) (the panel is not intended to comply with NCC H3D2(1)(g) as a whole).

Unless detailed otherwise above, all other systems shall be in accordance with the DtS provisions.

1.4 Variations to DtS Provisions and Performance Requirements

Table 1-1 lists the variations to the DtS requirements and the performance requirements as agreed by stakeholders.

Table 1-1 Variations from BCA-DtS provisions and performance requirements.

DtS reference	Issue	Performance Requirements	IFEG Subsystems
9.2.4(1)(a)	Use of a Class 10a structure located between a Class 1 building and an allotment boundary (that is not a boundary with a road or other public space) and positioned within 900 mm of the allotment boundary without a fire rated wall (FRL 60/60/60) between the Class 1 building and allotment boundary.	H3P1(1)	A – Fire initiation and development and control B – Smoke development and spread and control

1.5 Details of Standards Referenced in Report

The details of any acts, regulations, codes or standards which this report may reference are given in Table 1-2.

Table 1-2. Details of Standards - informative.

Reference in this Report	Year Version	Title
NCC	NCC 2022	ABCB National Construction Code 2022, Building Code of Australia – Housing Provisions Standard.
NCC	NCC 2022	ABCB National Construction Code 2022, Building Code of Australia – Volume 2.

2 Scope and Limitations

2.1 General

SOTERA has been engaged to carry out fire engineering assessment of the proposed performance solution for the project:

Client:	Delta Panels Pty Ltd
Project Title:	DeltaDualCore™ Panel Awning Systems

The following Fire Engineering Assessment has been conducted in order to address issues of variation from the Deemed-to-Satisfy (DtS) provisions of the National Construction Code 2022 Housing Provisions Standard & Volume 2 (ASCB 2022); hereafter referred to simply as the NCC. The fire engineering evaluation has been carried out in accordance with the methodologies defined in the International Fire Engineering Guidelines (IFEG 2005). This assessment considers the performance solution to show compliance with the performance requirements of the NCC. The evaluation methodology was based on direct compliance with performance requirements and/or equivalence to the deemed-to-satisfy provisions of the NCC as allowed under Part A2G1. This is supported by qualitative and quantitative evaluation analyses as allowed under Part A2G2 of the NCC.

2.2 Summary of Developments in Fire Engineering Report

Rev 1-11: This report has been updated to reflect the new recommended fixing position of the DeltaDualCore panel. Figure 3-4 has been updated.

Rev 1-10: This report has been updated to reflect the new version of the NCC, NCC 2022 which supersedes the outgoing NCC 2019 Amendment 1. The report is updated with regards to the applicable NCC 2022 clauses and performance requirements throughout.

Rev 1-9: The report has been updated following release of a new brochure. References to the applicable product brochure has been included throughout.

Further clarification has been added to the conclusion given in Section 4.9 as requested by CertMark.

Rev 1-8: Following further comments received from CertMark, the report has been updated to remove reference to a vehicle design fire, this has been replaced with a suitable fire scenario in Section 4.7.1.1.

Reference to NCC C1.9 has been replaced with NCC 3.7.1.1.

Rev 1-7: Following consultation with CertMark, the report has been updated to remove reference to carport applications. The assessment outlined within this report no longer permits the use of the DeltaDualCore™ panels as part of a carport structure.

Rev 1-6: The report has been updated following further comment by CertMark International. Main updates include:

- The performance requirement to be achieved has been clarified throughout to be P2.3.1(a).
- Design configuration 2 has been removed from the report. This report only addresses design configuration 1 (as described in Rev 1-5).
- The conclusion in Section 4.9 has been updated.

Rev 1-5: The report has been updated follow review by CertMark International. The main concerns raised by CertMark are summarised in Table 2-1 below.

Table 2-1. Summary of concerns raised by CertMark, Sotera responses and relevant sections actioned.

CertMark Concern	Sotera Response	Section Actioned
1. The SOTERA report does not appear to rely on any testing conducted to the DualCore panel. We appear not to have the overall panels tested to 1530.3. I also cannot see whether SOTERA have conducted any assessments of the testing noted in the above table against the DualCore panel or have argued the reports are valid against the DualCore Panel, having said that, I don't see this being acceptable to the UBC.	All relevant fire test reports and certificates have now been summarised in Table 3-4 and discussed in Section 3.3 which justifies that although no AS1530.3 test has been undertaken specifically on the DeltaDualCore™ panel, it is reasonable to extrapolate the results of the existing AS1530.3 tests to apply to the DeltaDualCore™ panel.	Table 3-4 and Section 3.3
2. The report appears to confirm the DualCore panel is a Bonded Laminate, however the evidence to support this claim is not clear.	Yes, rev 1-4 of the report confirms that the sandwich panels are bonded laminates but it does not claim that the bonded laminates comply with NCC 3.7.1.1(g). Further clarification has been added to Section 1.3(d)(iv) and Section 4.4.	Section 1.3(d)(iv) and Section 4.4
3. The report claims that sandwich panels produced with a non-composite core consisting solely of EPS-FR is outside the scope of this FER, however Design Configuration 2 incorporates such panels which presents a contradiction.	Section 3.2 has been revised to better describe the design configurations and system variations.	Section 3.2
4. SOTERA has not extrapolated tested thicknesses to products (75mm, 100mm, 150mm, 175mm)	Discussion has been included in Sections 3.3.2, 4.7.1.1 and 4.8.2.4. The assessment is independent of panel thickness as it assesses likelihood of fire spread from and to the site boundary.	Sections 3.3.2, 4.7.1.1 and 4.8.2.4
5. A fundamental problem here is that SOTERA has provided a Performance Solution, however this is not what CMI require for the purpose of certification. We will require a Qualitative assessment of the new product based on testing conducted to the individual products – an Evidence of Suitability report or alternatively testing conducted to the new product. We also need to be clear on what we are actually certifying, essentially,	As per the CodeMark protocol, the fire engineering assessment must identify the applicable NCC performance requirements and demonstrate how the proposed system achieves the performance requirements. This can be done using i) NCC verification method (quantitative), ii) alternative verification method (quantitative), iii) Comparison to DtS (quantitative or qualitative), and (iv) Expert Judgement (qualitative). When using any of these methods, the BCA refers to this as a performance solution and there is no requirement for the	Section 3.2

CertMark Concern	Sotera Response	Section Actioned
we have 3 panels available in 2 profiles and in 4 sizes (24 panels in total) noted in the report, with contradictions that Panel 2 from Design Config 2, being outside the scope of the certification.	<p>assessment to be strictly qualitative. We used method (iv) using qualitative and quantitative assessment to demonstrate that the applicable performance requirements are achieved in line with that permitted under the CodeMark protocol.</p> <p>The report addresses design configuration 1 and design configuration 2 as per Section 3.2, with DeltaOrb and DeltaTrim panels allowed to be used interchangeably to form the roof. Any perceived contradiction has been removed.</p>	

Rev 1-4: AS1530.3 fire test certificate for Bluescope Colorbond Permagard Steel has been added to Appendix D.

Rev 1-3: Further AS1530.3 fire test reports have been added in Appendix D for DeltaTrim™ and DeltaOrb™ sandwich panel systems.

Rev 1-2: Following further comments from the client, the report has been updated to clarify requirements for steel sheeting to be used as part of the DeltaDualCore™ panel system (Sections 1.3, 2.4, 3 & 4.4). Specifically, pre-finished steel sheeting with combustible surface finish not exceeding 1 mm thickness and with a spread of flame index no greater than 0 in accordance with NCC Clause 3.7.1.1(e).

Rev 1-1: Minor wording updates to clarify roof structure use as awning, patio or car port following review by the client.

Rev 1-0: This report aims to inform stakeholders to facilitate agreement on performance solutions. Information and agreement is sought on matters including: critical building and occupant characteristics, proposed details of performance solutions, DtS variations, issues, hazards, design fires and scenarios, methodologies and acceptability criteria.

2.3 Scope of Project.

The assessment relates to the final state of the building. This assessment and report does not address any issues of variation from deemed-to-satisfy requirements and occupant safety that may arise as a result of partial completion and partial occupation of the building. Analysis of intentional fire incidents such as arson is not contemplated as part of this assessment.

This assessment will address the issues of variation from deemed-to-satisfy provisions of the BCA, which are identified in the summary of this report (Section 1). The assessment is concerned primarily with the life safety of occupants. The fire safety systems to achieve this are outlined in the report in principle. The assessment does not consider property protection, business continuity issues, environmental protection and insurance requirements unless specifically identified within this report.

This assessment only addresses the specific issues identified in the context that the remainder of the building is fully compliant with the deemed-to-satisfy provisions of the NCC.

2.4 Supporting Information

The fire engineering assessment described in this report is based on the following information:

- i) Branz Fire Assessment Report FC10893-001: Assessment of Delta Panels Pty Ltd DeltaCool wall and DeltaTrim and DeltaOrb roofing systems for compliance with BAL-29 and BAL-40 Ratings of AS3959-2009.
- ii) CSIRO Certificate of Test: AS1530.1-1994 fire test certificate for Mineral Wool / Rockwool, Report No. FNC12604.
- iii) AWTA Product Testing: AS1530.3-1999 Test Report for DeltaOrb-EPS-FR, Test Number 19-003621.
- iv) AWTA Product Testing: AS1530.3-1999 Test Report for DeltaTrim-EPS-FR, Test Number 19-003623.
- v) CSIRO Certificate of Test: AS1530.3-1999 fire test certificate for Bluescope ZINCALUME Steel, Report No. FNE11602.
- vi) CSIRO Certificate of Test: AS1530.3-1999 fire test certificate for Bluescope COLORBOND Metallic Steel Polyester, Report No. FNE11602.
- vii) CSIRO Certificate of Test: AS1530.3-1999 fire test certificate for UniCote pre-painted steel sheeting, Report No. FNE11809A.
- viii) AWTA Product Testing: AS1530.3-1999 Test Report for Uni Zinc Rigid Panel, Test Number 20-000776.
- ix) AWTA Product Testing: AS1530.3-1999 Test Report for MagnaFlow Coated Steel Panel, Test Number 19-002186.
- x) DeltaDualCore™ Panels Brochure V27.08.21.
- xi) Architectural drawings referenced in Table 2-2.

Table 2-2. List of drawings relied upon.

Drawn by:	Delta Panels Pty Ltd	
Drawing No	Title	Revision
PATIO ON BOUNDARY_1	-	A
PATIO ON BOUNDARY_2	-	A
PATIO ON BOUNDARY_4	-	A

2.5 Stakeholders

This report may be relied on by the following stakeholders:

Client:	Delta Panels Pty Ltd 731 Boundary Rd, Richlands QLD 4076 John Guy Phone: 07 3271 2170 Email: johnguy@deltapanel.com
Certifying Authority:	CertMark International PO Box 7144, Sippy Downs QLD 4556 Tallisa Ireland Phone: 07 5445 2199 Email: talissa@CertMark.org

Fire Engineer: SOTERA Pty Ltd
225 Wickham Terrace, Spring Hill, QLD 4000
Margaret Tatum
Phone: 07 5562 0022
Email: Margaret.tatum@sotera.com.au

This report should not be relied on by other parties without the consent of the Client and SOTERA.

2.6 Limitations

The scope of this report is limited to the performance solutions described in the summary of this report; Section 1. The general scope of the report is based on the agreed fee proposals dated 9th February 2021 and subsequent acceptance of the scope from the client.

This report has been developed generally in accordance with standards, guidelines, practices and review procedures generally accepted in the building design and construction, and fire engineering communities.

The fire engineering assessment and the subsequent recommendations reflect the reasonable and practical efforts of SOTERA. The extent to which the fire safety requirements are implemented will affect the probability of achieving adequate fire safety margins. It is important to note, however, that SOTERA cannot guarantee that fire ignition and fire damage will not occur.

This report is an assessment specifically of the performance issues highlighted in Table 1-1 in the summary of this report.

3 DeltaDualCore™ System

3.1 Description of Application

This fire engineering report documents the assessment of DeltaDualCore™ panel awning and patio systems when used as a Class 10a structure (awning or patio) attached or adjacent to a Class 1a building positioned directly adjacent to the site boundary pursuant to NCC 2022 Housing Provisions Standard & Volume 2 and installed to the requirements of Section 4.4.

3.2 Description of System

The DeltaDualCore™ roofing system comprises:

- a) A sandwich panel roof system (refer to Figure 3-2, Figure 3-4 to Figure 3-5)
- b) Non-combustible support structure
- c) Non-combustible plumbing fixtures (gutters and downpipes)

The DeltaDualCore™ sandwich panel roof system comprises steel outer facings (0.45 mm Colorbond® steel upper facing and 0.55 mm UniCote® Steel lower facing – see Figure 3-1) with a composite core containing EPS-FR and mineral wool as shown in Figure 3-1 (i.e. the patented DeltaDualCore™ composite panel). The core comprises separate parts mineral wool and EPS-FR bonded together along a stepped seam as shown in Figure 3-2. The mineral wool component shall have a minimum length of 900 mm as shown in Figure 3-2.

Delta Panels produce the DeltaDualCore™ panel in two variations (see Figure 3-3), one with a trapezoidal upper facing (referred to as the DeltaTrim™ system) and one with a corrugated upper facing (referred to as the DeltaOrb™ system). The composition of the facing material for both the DeltaTrim™ and DeltaOrb™ systems are identical, it is only the profile of the upper facing that is varied. Based on the assessment provided in Section 3.3.2, the profile of the upper facing does not have any significant effect on the achieved fire performance of the DeltaOrb™ and DeltaTrim™ panels. As such, the DeltaOrb™ and DeltaTrim™ panels may be used interchangeably and the outcomes of this assessment remain applicable to both panel types.

Material specifications as given by Delta Panels is quoted in Table 3-1.

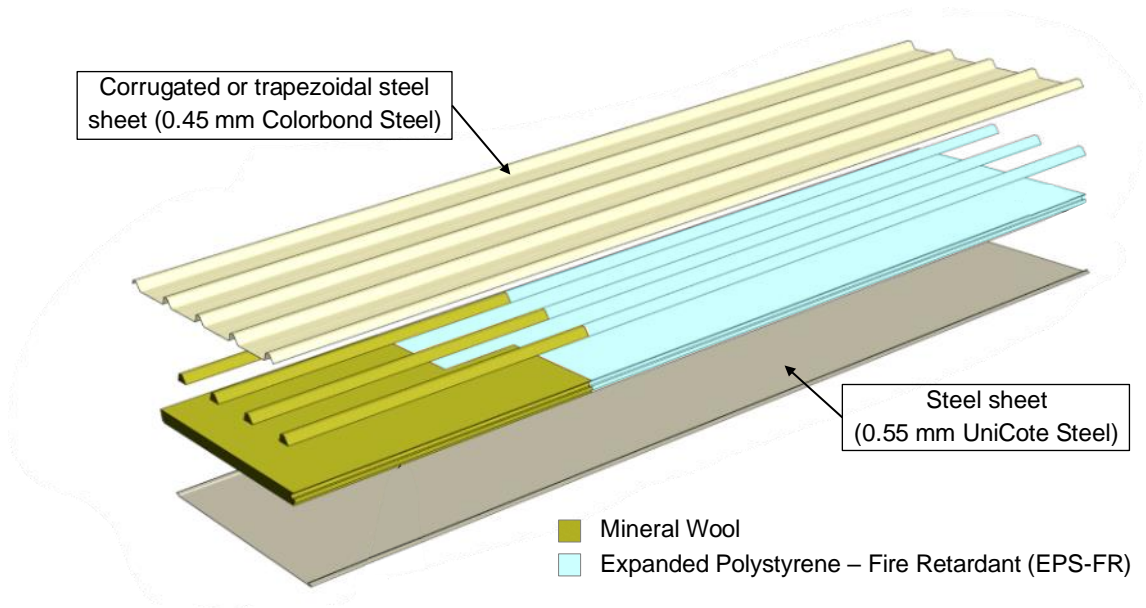

Figure 3-1. DeltaDualCore™ Panel (DeltaDualCore™ Panels Brochure V27.08.21).

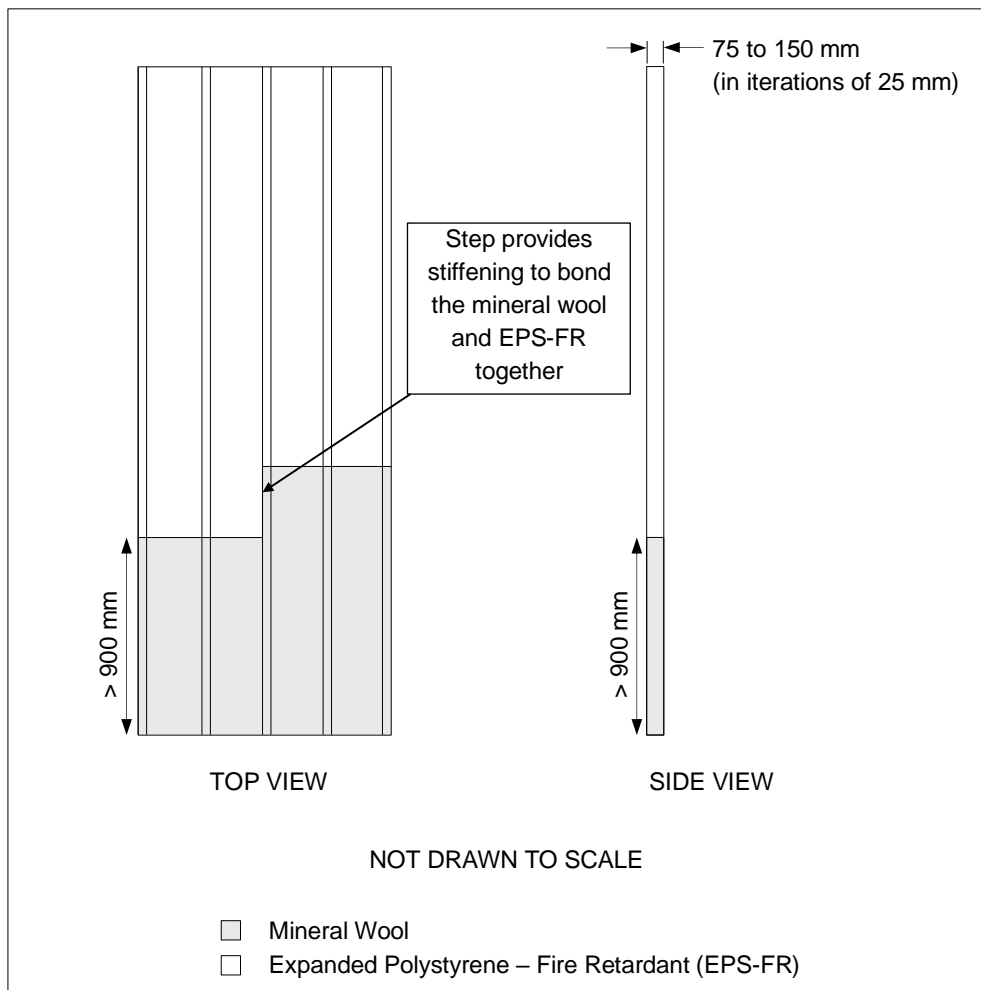

Figure 3-2. Sketch showing the composition and dimensioning of the composite core of the DeltaDualCore™ Panel.

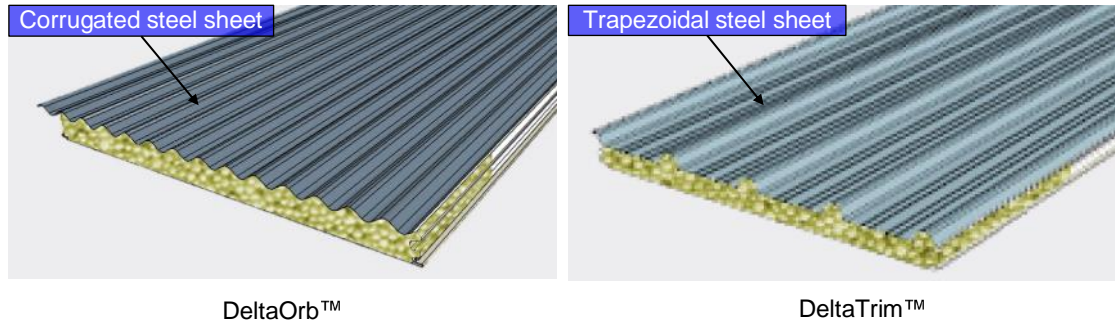

Figure 3-3. Illustration of DeltaOrb™ and DeltaTrim™ systems showing the difference in top skin (DeltaDualCore™ Panels Brochure V27.08.21).

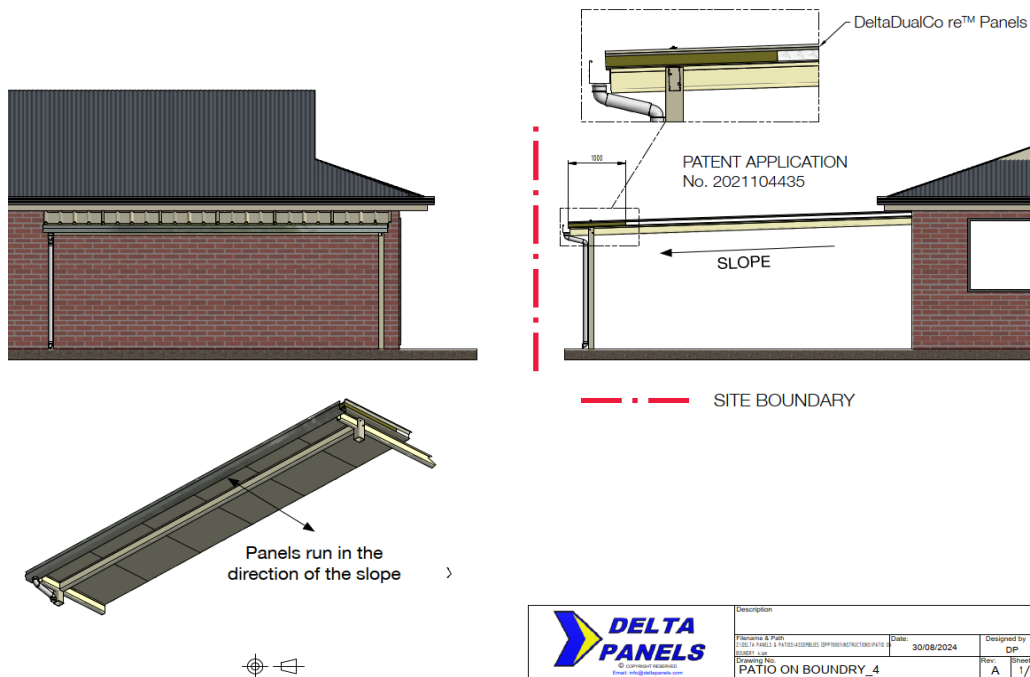
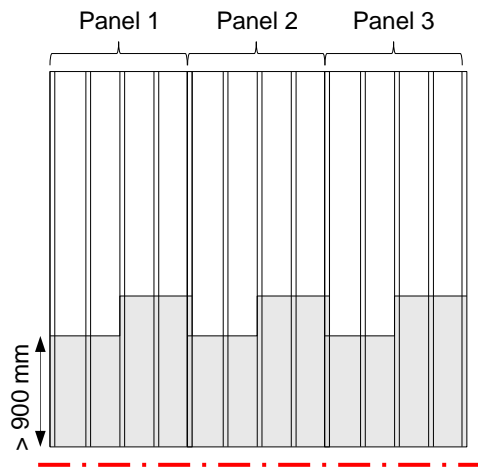

Figure 3-4. DeltaDualCore™ system sloping towards the site boundary.



NOT DRAWN TO SCALE

- Mineral Wool - · - Site boundary
- Expanded Polystyrene – Fire Retardant (EPS-FR)

Figure 3-5. Sketch illustrating DeltaDualCore™ orientation to the site boundary.

Table 3-1. Manufacturers material specification (DeltaDualCore™ Panels Brochure V27.08.21).

Steel skin detail	Top skin	0.45 mm Colorbond Steel
	Bottom skin	0.55 mm Unicote Steel
Core material	- SL grade Polystyrene with fire retardant - Mineral wool	
Thermal conductivity	Min. 0.0363 W/mK @ 23.0°C	
Adhesive	Thermosetting two-part adhesive	
R Value @22.5°C	75 mm Panel	2.08
	100 mm Panel	2.78
	125 mm Panel	3.48
	150 mm Panel	4.17
Sheet coverage	1000 mm	
Density	Average density for a 6 m panel is 30.8 kg/m ³	
Length (mm)	Min. of 1800 mm (cut to length)	
Thickness (mm)	75, 100, 125, 150	
Weight (kg/m ²)	75 mm Panel	13.9
	100 mm Panel	14.7
	125 mm Panel	16.7
	150 mm Panel	18.7
Minimum roof pitch	DeltaTrim™ - 2°	
	DeltaOrb™ - 3°	

Table 3-2. DeltaOrb™ fixing details (crest fixing only, one fixing every second crest).

Panel Thickness	Fixing into steel
75	Tek 14 x 135 Hex Head Screw
100	Tek 14 x 150 Hex Head Screw
125	Tek 14 x 175 Hex Head Screw
150	Tek 14 x 200 Hex Head Screw

*Use cyclone plate and neo washer on each fixing. Upon installation the overlap needs to be stitch screwed or riveted every 300mm

Table 3-3. DeltaTrim™ fixing details (crest fixing only, one fixing every second crest).

Panel Thickness	Fixing into steel
75	Tek 14 x 150 Hex Head Screw
100	Tek 14 x 175 Hex Head Screw
125	Tek 14 x 200 Hex Head Screw
150	Tek 14 x 230 Hex Head Screw

*Use cyclone plate and neo washer on each fixing. Upon installation the overlap needs to be stitch screwed or riveted every 300mm

3.3 Fire Test Certificates

3.3.1 Summary of Relevant Fire Test Certificates

Relevant fire test certificates referenced within this assessment are given in Table 3-4.

Three test methods are referenced, AS1530.1, AS1530.3 and AS3959.

AS1530.1 specifies a test method for the determination of combustibility of a building material (this test method is material specific, each component of a system is tested separately). This test identifies whether a material is deemed combustible or not.

AS1530.3 sets out a test method for the assessment of building materials and components according to their tendency to ignite, propagate flame, release smoke and release heat following ignition. (This test is not material specific, components may be tested as a system). This test assesses each of these characteristics during the incipient stage of fire, providing an index rating to indicate the severity of each of these characteristics.

AS3959 specifies requirements for the construction of buildings in bushfire-prone areas in order to improve their resistance to bushfire attack from burning embers, radiant heat, flame contact and combination of the three attack forms.

Table 3-4. Applicable fire test certificates.

Mineral Wool (MW)			
Test	Report	Test Specimen	Relevant Performance
1. AS1530.1:1994	CSIRO Report No. FNC12604 (refer to Section C.1)	50 mm thickness, 100 kg/m ³	Not deemed combustible
2. AS1530.3:1999	AWTA Test No. 18-006075 (refer to Section D.9)	Pre-painted steel skins (DeltaCool™) with MW core of 125 mm thickness and density of 100 kg/m ³ .	Indices: Ignitability: 0 Spread of Flame: 0 Heat Evolved: 0 Smoke Developed: 2

Sandwich Panel with Expanded Polystyrene (EPS) Core			
Test	Report	Test Specimen	Relevant Performance
3.	AS1530.3:1999	AWTA Test No. 19-003621 (refer to Section D.1)	Pre-painted steel skins (DeltaOrb™) bonded to an EPS core with fire retardant. Indices: Ignitability: 0 Spread of Flame: 0 Heat Evolved: 0 Smoke Developed: 2
4.	AS1530.3:1999	AWTA Test No. 19-003623 (refer to Section D.2)	Pre-painted steel skins (DeltaTrim™) bonded to an EPS core with fire retardant. Indices: Ignitability: 0 Spread of Flame: 0 Heat Evolved: 0 Smoke Developed: 2
5.	AS3959:2009	Branz Fire Assessment Report FC10893-001 (refer to Appendix F)	DeltaTrim™ and DeltaOrb™ steel facings (0.40 mm or 0.60 mm) with EPS core with thickness up to 150 mm thick. DeltaOrb™ - BAL40 DeltaTrim™ - BAL40
Coated Steel Facings			
Test	Report	Test Specimen	Relevant Performance
6.	AS1530.3:1999	CSIRO Report No. FNE11602 (refer to Section D.3)	BlueScope ZINCALUME Steel (0.5 mm nominal thickness) Indices: Ignitability: 0 Spread of Flame: 0 Heat Evolved: 0 Smoke Developed: 2
7.	AS1530.3:1999	CSIRO Report No. FNE11604 (refer to Section D.4)	BlueScope COLORBOND steel (0.8 mm nominal thickness) Indices: Ignitability: 0 Spread of Flame: 0 Heat Evolved: 0 Smoke Developed: 2
8.	AS1530.3:1999	CSIRO Report No. FNE11603 (refer to Section D.5)	Bluescope COLORBOND Permagard Steel (0.7 mm nominal thickness) Indices: Ignitability: 0 Spread of Flame: 0 Heat Evolved: 0 Smoke Developed: 1
9.	AS1530.3:1999	AWTA Test No. 19-002186 (refer to Section D.6)	MagnaFlow Coated Steel Panel (nominal mass per unit density 7850 kg/m ³) Indices: Ignitability: 0 Spread of Flame: 0

				Heat Evolved: 0
				Smoke Developed: 3
10.	AS1530.3:1999	CSIRO Report No. FNE11809A (refer to Section D.7)	UniCote steel (0.55 mm nominal thickness)	Indices: Ignitability: 0 Spread of Flame: 0 Heat Evolved: 0 Smoke Developed: 2
11.	AS1530.3:1999	AWTA Test No. 20-000776 (refer to Section D.8)	UniZinc (low carbon steel) Rigid Panel (< 1 mm nominal thickness)	Indices: Ignitability: 0 Spread of Flame: 0 Heat Evolved: 0 Smoke Developed: 0-1

3.3.2 Extrapolation of Fire Test Results

All relevant fire testing referenced within this report are given in Table 3-4 with a summary of the fire performance achieved in each case.

A number of coated steel and steel-alloy sheet metals have been tested to AS1530.3:1999 both independently and as part of a sandwich panel. When tested independently (tests 6 to 11 in Table 3-4), the test results obtained for each AS1530.3 index (Ignitability, Spread of Flame, Heat Evolved and Smoke Developed) are almost identical with only a small variance in the Smoke Developed Index. In all cases, the AS1530.3 results are within the following value range:

- Ignitability Index: 0
- Spread of Flame Index: 0
- Heat Evolved Index: 0
- Smoke Developed Index: 0-3

When the AS1530.3 test is repeated with the steel facings bonded either side of a material deemed not combustible under AS1530.1, in this case mineral wool (tests 1 and 2 in Table 3-4), the results give a near identical outcome to tests 6 to 11 in Table 3-4, that is:

- Ignitability Index: 0
- Spread of Flame Index: 0
- Heat Evolved Index: 0
- Smoke Developed Index: 2

Similarly, when the AS1530.3 test is repeated with the steel facings bonded either side of a combustible EPS core material (tests 3 and 4 in Table 3-4), the results again provide a near identical outcome to tests 6 to 11 in Table 3-4, that is:

- Ignitability Index: 0
- Spread of Flame Index: 0
- Heat Evolved Index: 0
- Smoke Developed Index: 2

Based on these results and with reference to the tested facings and substrates, the tested indices are independent of the substrate to which the coated metallic facings are bonded. The results are indicative only of the fire performance of the coated metallic facings during the early stages of fire development, before involvement of the substrate. As such, the test results are independent of the thickness of the core material used (substrate) to which the coated metallic facings are bonded.

Although no AS1530.3 test has been undertaken specifically on the DeltaDualCore™ panel, based on the above deduction from the available AS1530.3 tests, it is reasonable to extrapolate the results to be applied to the DeltaDualCore™ panel consisting of coated metallic facings (complying with Table 3-1) bonded to a substrate consisting of a composite material comprising EPS and mineral wool bonded together along a stepped seam (as shown in Figure 3-2).

Furthermore, the AS1530.3 results in tests 3 and 4 (Table 3-4) indicate that the DeltaOrb™ system and the DeltaTrim™ system achieves identical early fire hazard performance. The AS3959 results in test 5 (Table 3-4) indicate that the DeltaOrb™ and DeltaTrim™ systems achieve identical performance in terms of the achieved Bushfire Attack Level (BAL) rating. Based on these results, the differing profiles of the DeltaOrb™ and DeltaTrim™ systems do not appear to have any significant effect on the achieved fire performance of the panels. As such, the DeltaOrb™ and DeltaTrim™ panels may be used interchangeably and the outcomes of this assessment remain applicable to both panel types.

The AS1530.1 test provides determination of combustibility for each material independently. The mineral wool has been tested to AS1530.1 (test 1 in Table 3-4) and is deemed not combustible. Furthermore, NCC H3D2(1)(e) permits pre-finished metal sheeting having a combustible surface finish not exceeding 1 mm with a spread of flame index not greater than 0 to be used wherever a non-combustible material is required. As such, the coated metallic facings used in the DeltaDualCore™ system comply with NCC H3D2(1)(e) and therefore may be regarded as non-combustible under the DtS provisions of the NCC (no further AS1530.1 test is necessary).

This assessment is based on the assumption that EPS is combustible and has the thermal characteristics outlined in Table 3-5. The values given in Table 3-5 were obtained through bench-scale testing that was undertaken by the University of Queensland (UQ) and is available in the UQ cladding material library as sample INS04.

Table 3-5. Key thermal properties of EPS in the University of Queensland Cladding Material Library under sample ID INS04.

Criteria	Symbol	Unit	INS04 (99% EPS Core)
Gross heat of combustion	ΔH_c	$\frac{kJ}{g}$	39.20
Critical heat flux for ignition	\dot{q}''_{cr}	$\frac{kW}{m^2}$	20.50
Ignition temperature	T_{ig}	°C	434
Peak HRRPUA (average) at:	\dot{q}''_p	$\frac{kW}{m^2}$	
At Heat flux of 35 kW/m ²			228.06
At Heat flux of 50 kW/m ²			291.11
At Heat flux of 60 kW/m ²			332.23
Total energy released (average) at:	Q_t	$\frac{MJ}{m^2}$	
At Heat flux of 35 kW/m ²			28.43
At Heat flux of 50 kW/m ²			28.22
At Heat flux of 60 kW/m ²			24.52

4 DeltaDualCore™ Awning or Patio within 900 mm of Site Boundary

4.1 Assessment Task Defined

4.1.1 Background

This performance solution assesses the use of the DeltaDualCore™ roofing system when used as an awning or patio attached to a Class 1 building and positioned within 900 mm of the allotment boundary.

4.1.2 Issue

Where a Class 10a structure is located between a Class 1 building and an allotment boundary (that is not a boundary with a road or other public space) and positioned within 900 mm of the allotment boundary, NCC 9.2.4(1)(a) requires that a fire rated wall (FRL 60/60/60) be provided between the Class 1 building and allotment boundary; see Figure 4-1.

It is proposed to have no fire wall protection to the DeltaDualCore™ awning or patio system when positioned within 900 mm of the site boundary in variation to NCC 9.2.4(1)(a).

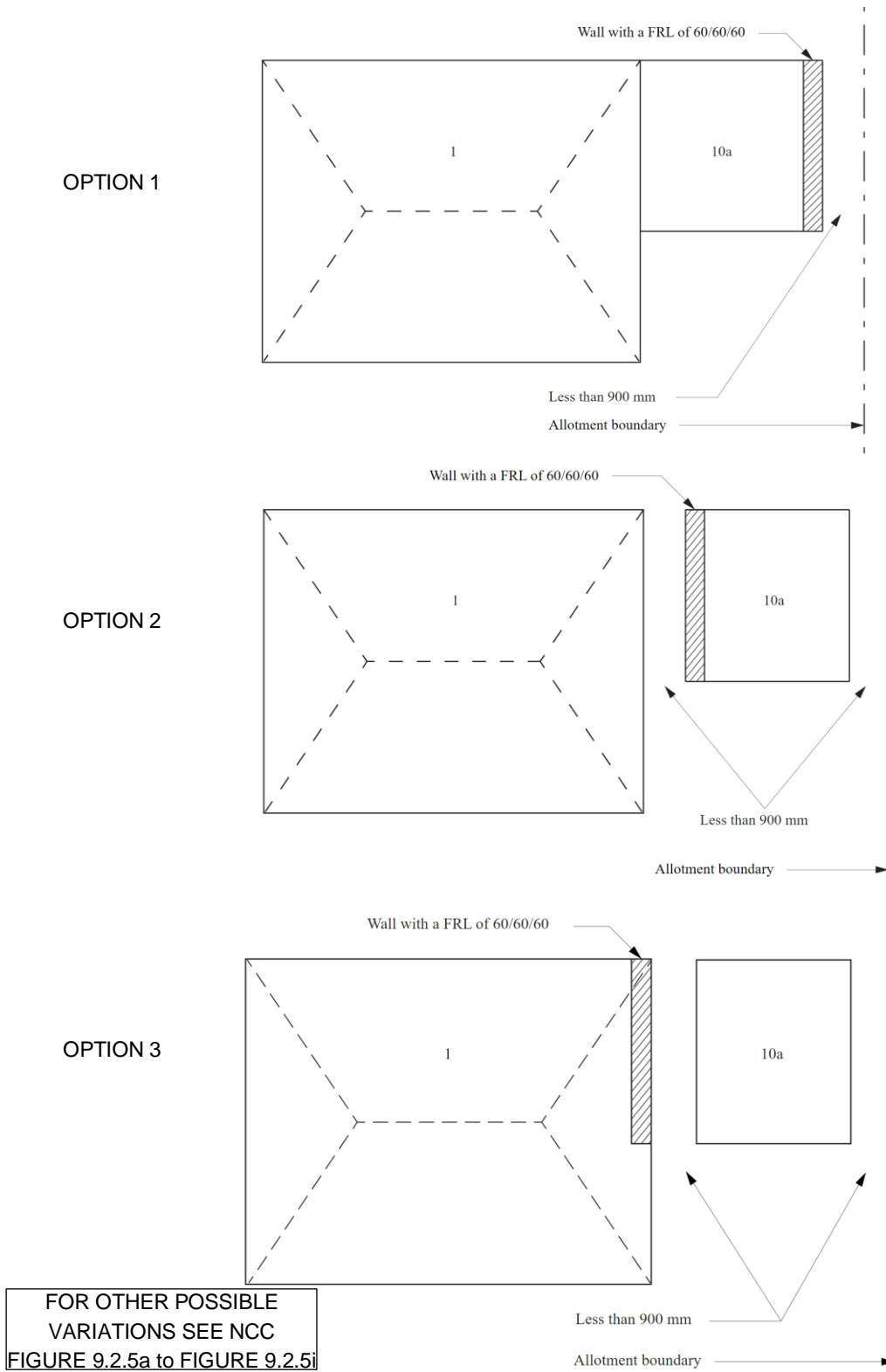

Figure 4-1. Fire rated wall (FRL 60/60/60) required where a Class 10a structure is located between a Class 1 building and an allotment boundary (that is not a boundary with a road or other public space) and positioned within 900 mm of the allotment boundary (adapted from NCC Figures 9.2.5a to FIGURE 9.2.5j).

4.2 Hazards

4.2.1 Specific Hazard

The NCC Schedule 1 defines fire hazard as the danger in terms of potential harm and degree of exposure arising from the start and spread of fire and the smoke and gases that are thereby generated. As such, the BCA definition of a hazard relates to the potential for occupants to be exposed to heat and/or smoke.

The intent of NCC 9.2.4 & 9.2.9 is to reduce the risk of fire spread between Class 1 buildings on neighbouring allotments as per performance requirement H3P1(1). The hazard associated with the variations to NCC 9.2.4 & 9.2.9 is the potential for fire spread between buildings to expose occupants to heat and/or smoke.

Whether the DeltaDualCore™ system when used within 900 mm of a site boundary presents an unacceptable risk of fire spread between buildings (which could significantly increase the hazard of building occupants becoming exposed to heat and/or smoke) must be assessed.

The identified hazard shall be considered in three fire scenarios (see Figure 4-2):

- i) Fire starting in the Class 1 building.
- ii) Fire starting below/in the Class 10a structure.
- iii) Fire starting on the neighbouring site.

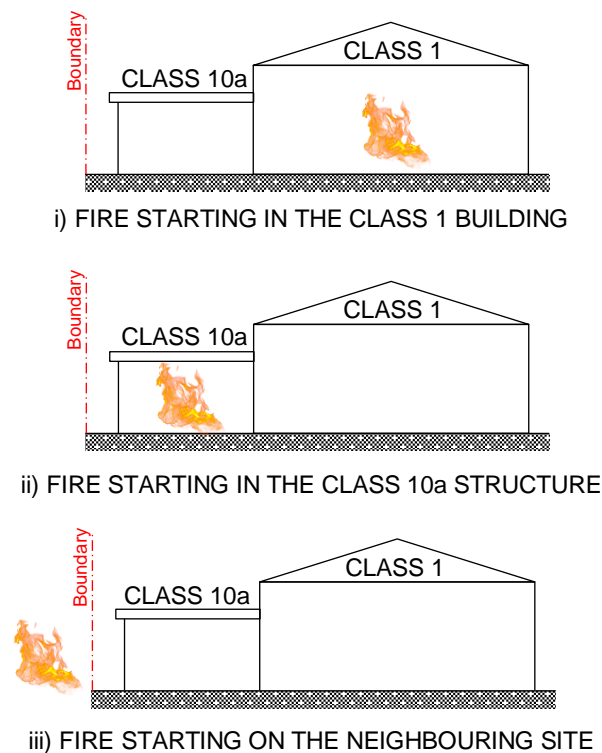

Figure 4-2. Fire scenarios to be considered to assess the identified hazard.

4.2.2 General Hazard

The following statistics indicating type and severity of domestic fires was obtained from Dowling and Ramsay (1997), Australian Bureau of Statistics: Home Fire Safety (2000), Fire Statistics UK (2002):

- 70% of fires are caused by the misuse of equipment including cooking appliances, candles, heaters, electrical appliances
- 20% of fires are due to arson
- 10% of fires are due to electrical faults
- 3% of fires start outside
- 2.2% of fires, which start inside, spread beyond the building of origin
- 76% of reported fires do not spread beyond the room of origin whether by good fortune or by occupant intervention
- 80% of fires are not reported to the fire brigade. They are extinguished by occupants while the fires are small
- 30% of fires start in kitchens, 10% in bedrooms i.e. approximately 3% per bedroom.

From the above statistics it is evident that only a small fraction of reported residential home fires start outside the building and an even smaller fraction of fires that start inside the building, spread beyond the building of fire origin. Unreported fires (which make up approximately 80% of all fires) are typically those that are extinguished, further reducing the number of fires that spread beyond the building of fire origin. Based on the statistics, as the building contains fire load of a relatively small scale, it is unlikely that a fire within the building will spread to the neighbouring building and as a result, the hazard of occupants being exposed to heat and/or smoke is low.

4.3 Performance to be Assessed

The performance solution must be assessed for whether it mitigates the identified hazards to performance requirement:

H3P1 – Spread of Fire:

- (1) A Class 1 building must be protected from the spread of fire such that the probability of a building not being able to withstand the design heat flux of 92.6 kW/m² for a period of 60 minutes shall not exceed 0.01, when located within 900 mm from the allotment boundary or within 1.8 m from another building on the same allotment from –
 - (a) Another building other than an associated Class 10 building; and
 - (b) The allotment boundary, other than a boundary adjoining a road or public space.

4.4 Systems

The systems proposed are:

- This performance solution is solely applicable to the DeltaDualCore™ roofing system which may comprise either DeltaTrim™ or DeltaOrb™ dual core sandwich panels with a core consisting of Expanded Polystyrene with fire retardant (EPS-FR) and mineral wool composite (refer to Section 3 describing the permitted system), non-combustible supporting structure and non-combustible plumbing fixtures (gutters and downpipes).
- All components used in the awning construction shall be compliant with Section 3. The components shall not be modified except with the written authorisation of the manufacturer and SOTERA.
- The following restrictions apply for the Class 10a awning installation:

- (a) Two or more sides (making up at least one third of the awning perimeter) shall be “open”; that is the roof covering shall be more than 500 mm from another building or allotment boundary on at least two sides without enclosing these sides with a wall, privacy screen or the like within 500mm of the edge of the roof covering. A boundary along a road or public space such as parklands, lakes, rivers and the like (where the construction of buildings is unlikely) may be considered open regardless of proximity to the boundary subject to no vertical obstruction (wall, privacy screen or the like) within 500 mm of the edge of the roof covering.
- (b) The awning structure shall not provide direct vertical support to any part of the adjacent Class 1 building.
- (c) The portion of the awning system which is located within 900 mm of a site boundary shall consist solely of non-combustible components (subject to (d)) including:
 - (i) Mineral wool
 - (ii) Pre-finished steel sheeting with combustible surface finish not exceeding 1 mm thickness and with a spread of flame index no greater than 0 in accordance with NCC Clause H3D2(1)(e).
 - (iii) Steel fixtures, gutters and the like
 - (iv) Steel columns, beams, purlins and the like
 - (v) Metallic flashing
- (d) As each sandwich panel used in the DeltaDualCore™ system constitutes a bonded laminate, the following restrictions shall apply to the portion of the roof system that is within 900mm of the site boundary:
 - (i) The lamina's shall be restricted to steel facings with mineral wool core, each of which has been tested to AS1530.1 and are deemed non-combustible (refer to AS1530.1 fire test certificates in Section Appendix A).
 - (ii) Each adhesive layer may not exceed 1 mm in thickness and the total combined thickness of adhesive layers may not exceed 2 mm (refer to Section Appendix E which confirms adhesive layer thicknesses are within the required limits).
 - (iii) The spread of flame index and the smoke developed index of the bonded laminated material as a whole shall not exceed 0 and 3 respectively (refer to AS1530.3 test certificates given in Section Appendix D).
 - (iv) Only the portion of each DeltaDualCore™ panel containing a mineral wool core shall comply with items i) to iii) in accordance with NCC H3D2(1)(g) (the panel is not intended to comply with NCC H3D2(1)(g) as a whole).

4.5 Methodology

The method of assessment is qualitative and quantitative to justify the risk and mitigate the hazard as identified in section 4.2.

Performance requirements are addressed comparatively in accordance with BCA A2G2(1)(b) and A2G2(2)(d).

Firstly, the DtS base case used for comparison must be established. The DtS base case shall present an equivalent DtS building which provides an acceptable benchmark against which to assess the proposed performance solution.

The DtS base case will consist of a Class 1 house with a DtS Class 10a structure attached to the house. The comparison case will consist of an identical Class 1 house, at an identical distance from the site boundary, with the proposed Class 10a structure attached to the house. Refer to Figure 4-3.

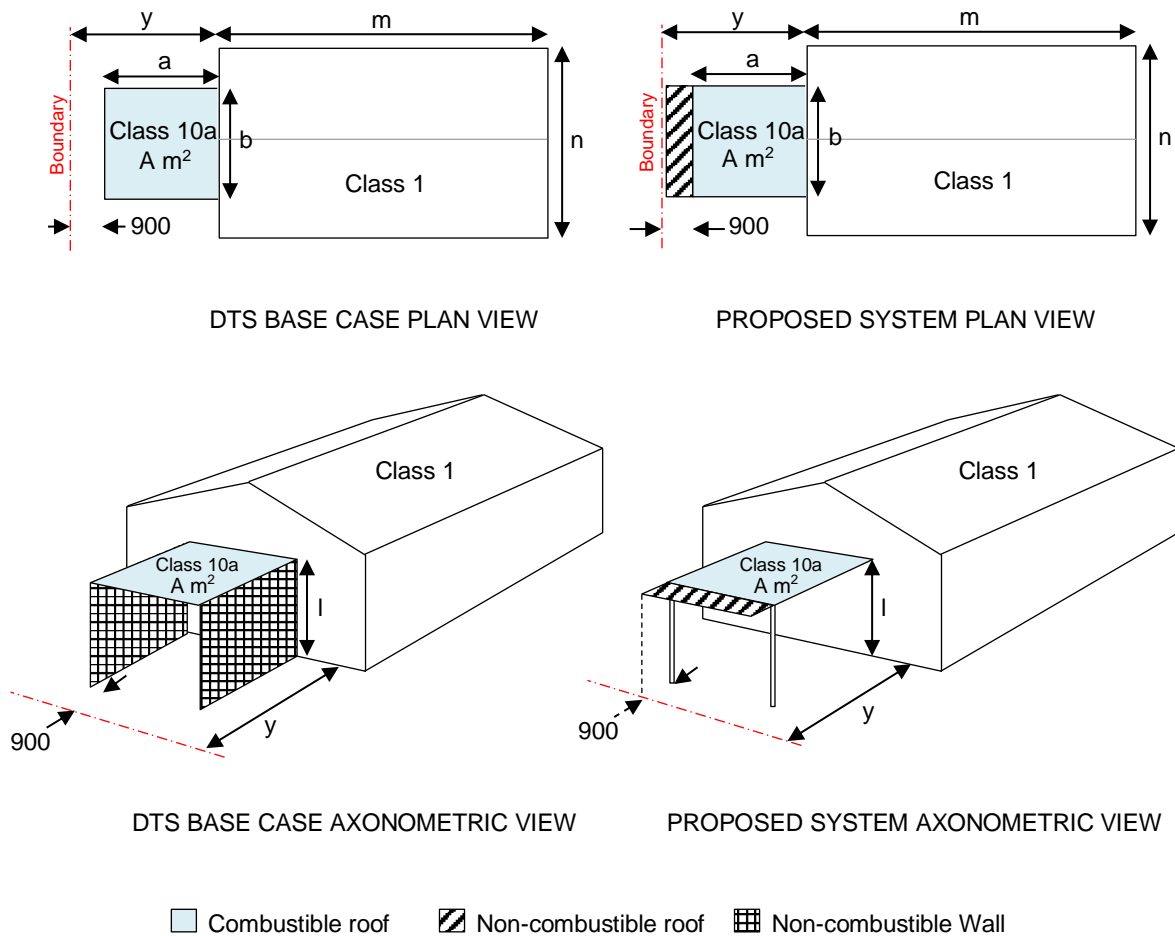

Figure 4-3. Illustration of DtS base case that will be used for comparison to the proposed system.

4.6 Acceptability Criteria

It shall be demonstrated comparatively that the DeltaDualCore™ system (when attached to a Class 1 building within 900 mm of the site boundary) does not increase the risk of fire spread between Class 1 to Class 9 buildings when compared to the DtS base case.

4.7 Design Fires

Three fire scenarios are to be considered; one within the Class 1 building, one within or below the Class 10a structure and one on the neighbouring allotment. The three design fires are described in Sections 4.7.1.1 to 4.7.1.3 below.

4.7.1.1 Design Fire 1: Fire Within or Below the Class 10a Structure

In the case of a Class 10a structure intended to be used for a patio or awning application, fire load is likely to be limited as it would not be fully protected from the weather. However, the patio or awning is able to house a wide range of fire loads which may include a combination combustibile goods such as external furnishings, storage of household goods, a laundry rack, gardening supplies and the like.

To quantify a worst credible design fire the following fire loads are considered:

- Upholstered Sofas – 500 kW to 2900 kW as shown in Figure 4-4.

- Staked chairs – 2250 kW Peak HRR for 12 chairs (upholstered seat with metal frame) in two stacks as shown in Figure 4-5.
- Laundry – 400 kW peak HRR for 10 shirts hanging on a rail; see Figure 4-6.
- Miscellaneous furnishings – timber desk with a peak HRR of 650 kW; see Figure 4-7.

Assuming that the patio contains a three-seater upholstered sofa, 12 upholstered chairs with metal frames in stacks of 6 chairs side by side, a laundry rack with 10 T-shirts and a small table approximated as a timber desk; the combined peak HRR (if all fire loads reached their peak HRR simultaneously) is 6200 kW.

As the fire is expected to start from a single ignition source and potentially spread to surrounding objects if the fire grows to a large enough size, different objects would be within different stages of fire growth and decay. Assuming that all objects will ignite, grow and peak simultaneously is not a realistic fire scenario. As such, the overall fire size and intensity is likely to be far less than 6200 kW, so this peak HRR is conservative.

Due to the uncertainty of potential fire loads that can be placed below the Class 10a awning, a further safety margin of approximately 1.6 is applied to the peak HRR. The design fire is therefore taken as 10 MW. To put this into perspective, this is equivalent to a large passenger vehicle fire. Thus, a design fire with peak HRR of 10 MW provides a worst credible fire scenario for use in the assessment. To eliminate time dependency, a steady state fire at a heat release rate of 10 MW will be used for assessment purposes.

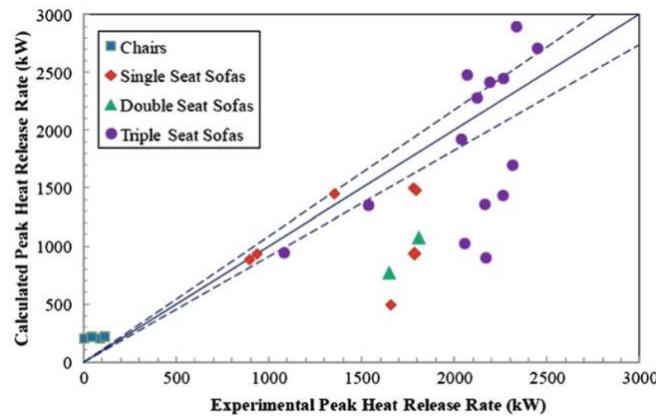

Figure 4-4. Peak HRR of upholstered sofas (SFPE handbook 2016).

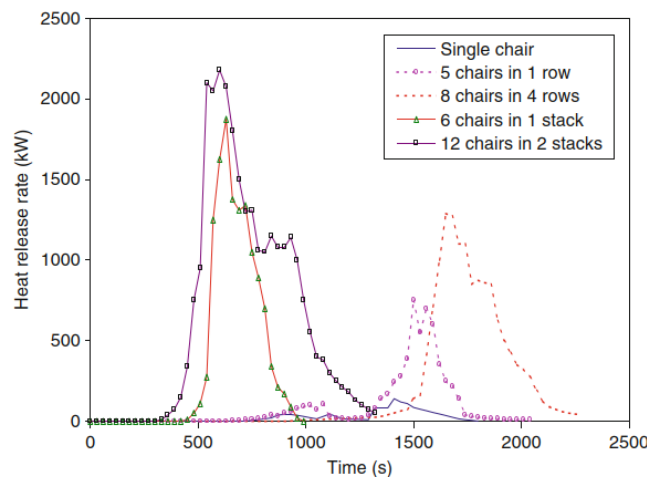

Figure 4-5. HRR of metal frame upholstered chairs (SFPE handbook 2016).

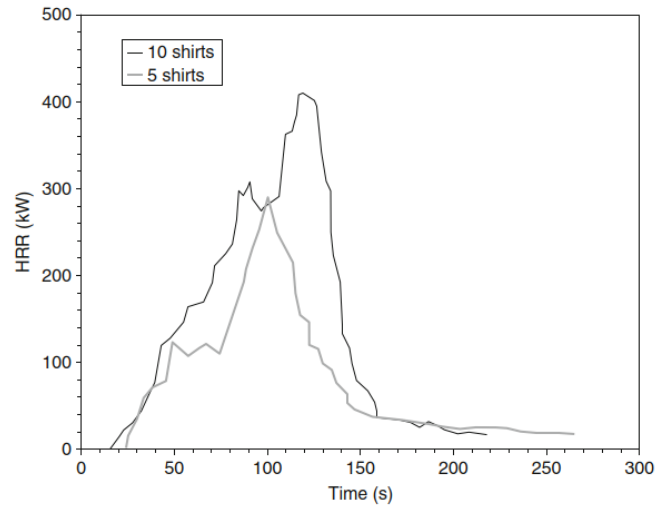

Figure 4-6. HRR of shirts hanging on a rail (SFPE handbook 2016).

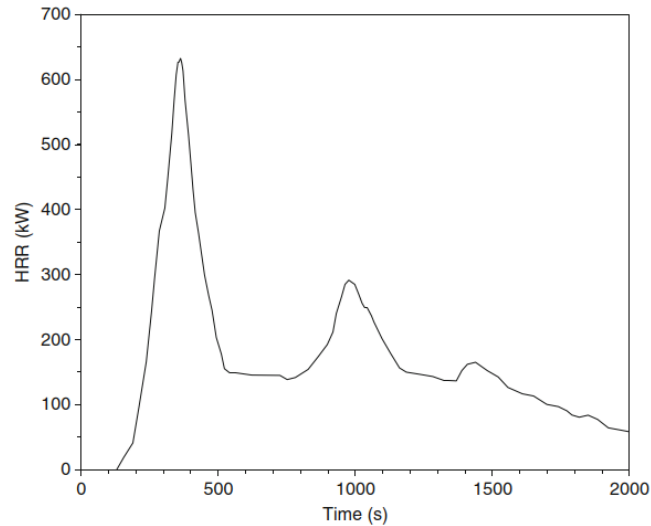

Figure 4-7. HRR of a 0.6 x 1.2 x 0.8 m wooden desk (SFPE Handbook 2016).

4.7.1.2 Design Fire 2: Fire Within the Class 1 House

The peak heat release rate for a dwelling fire load is based on full-scale fire test data of a typical apartment fire (Alam and Beever, 1996) which is expected to have the same fire load density to that of a house. The measured heat release rate is given in Figure 4-8 and shows that a peak heat release rate of 7.5 MW is reached at flashover.

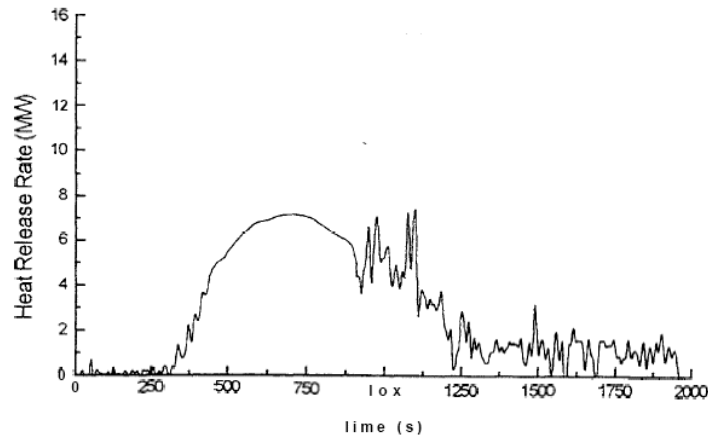

Figure 4-8. Typical uncontrolled apartment fire (Alam and Beaver 1996).

4.7.1.3 Design Fire 3: Fire Spread from the Site Boundary to the Class 10a Structure

The fire source feature presented by the site boundary is taken as a radiating panel with transient temperature following the AS1530.4 standard fire time-temperature curve which increases to over 1050°C. This provides a more conservative assessment than simply assessing a NCC H3V3 fire source (equivalent to C1V1 in NCC Volume 1) with a constant heat flux of 80 kW/m² from the site boundary (which is equivalent to a radiating panel with a temperature of 817°C).

The standard fire curve is described by the equation:

$$T = 345 \log_{10} \left(\frac{8t}{60 + 1} \right) + 20$$

4.8 Assessment

4.8.1 DtS Base Case

NCC does not restrict the combustibility of a Class 10a structure attached to a Class 1 structure if it is located more than 900 mm from the site boundary.

As such, the risk of fire spread from, or to the site boundary is mitigated to a DtS accepted level of risk (i.e. to the degree necessary) with a spatial separation of 900 mm regardless of ventilation conditions.

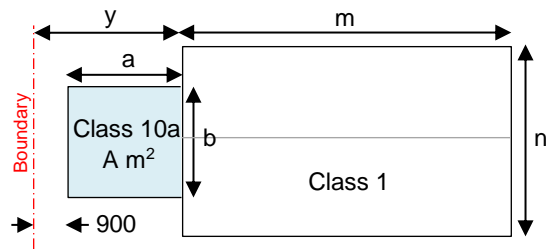

DTS BASE CASE PLAN VIEW

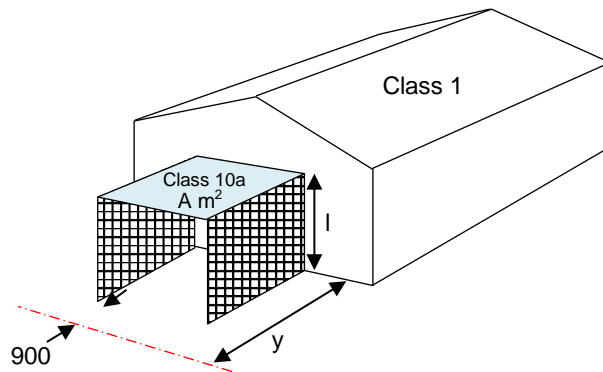

DTS BASE CASE AXONOMETRIC VIEW

Combustible roof
 Non-combustible Wall

Figure 4-9. DtS base case: Class 10a structure with combustible roof enclosed along three sides located within 900 mm of the site boundary.

Figure 4-10 illustrates the dominant mechanisms for heat transfer to the site boundary from a fire below the Class 10a structure for the DtS base case.

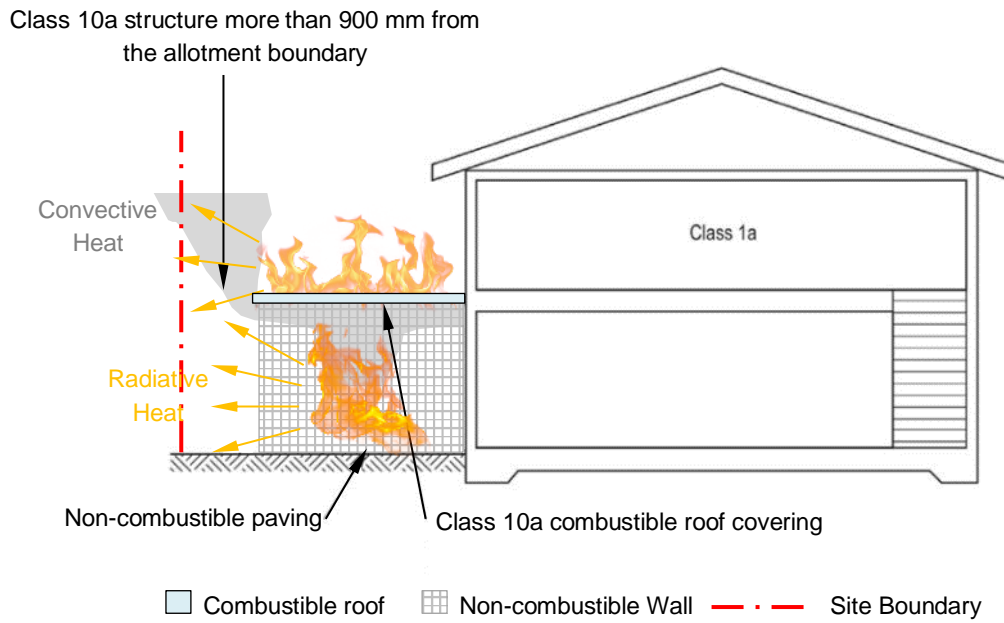
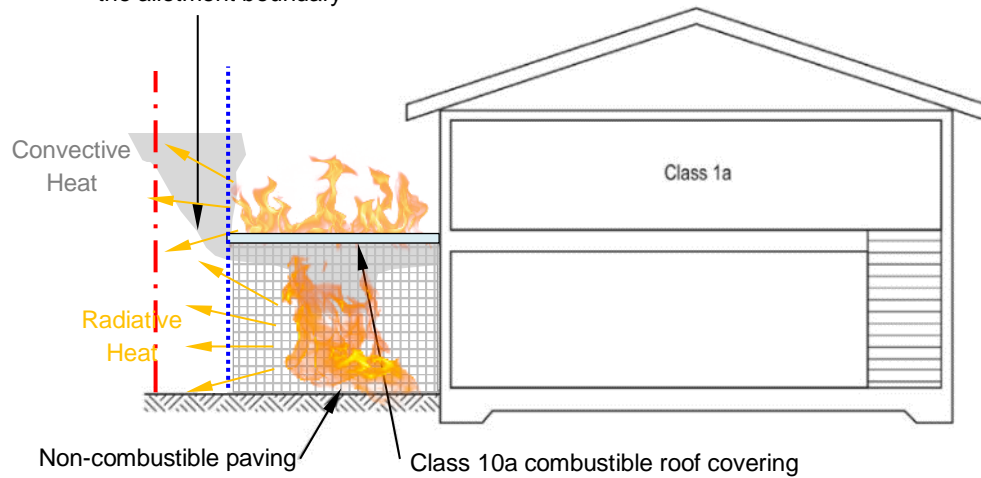

Figure 4-10. DtS base case: Mechanisms for heat transfer from a fire below a combustible Class 10a awning more than 900 mm from the site boundary.

4.8.2 Assessment of DeltaDualCore™ Against the Applicable DtS Configurations

Figure 4-11 to Figure 4-13 indicates the dominant mechanisms for fire spread to the site boundary for the DeltaDualCore™ system when attached to a Class 1 building and positioned within 900mm of a site boundary in comparison to the DtS base case for each of the three fire scenarios.

Class 10a structure more than 900 mm from the allotment boundary



Combustible roof
 Non-combustible Wall
 Site Boundary
 900 mm set back from site boundary

DTS BASE CASE

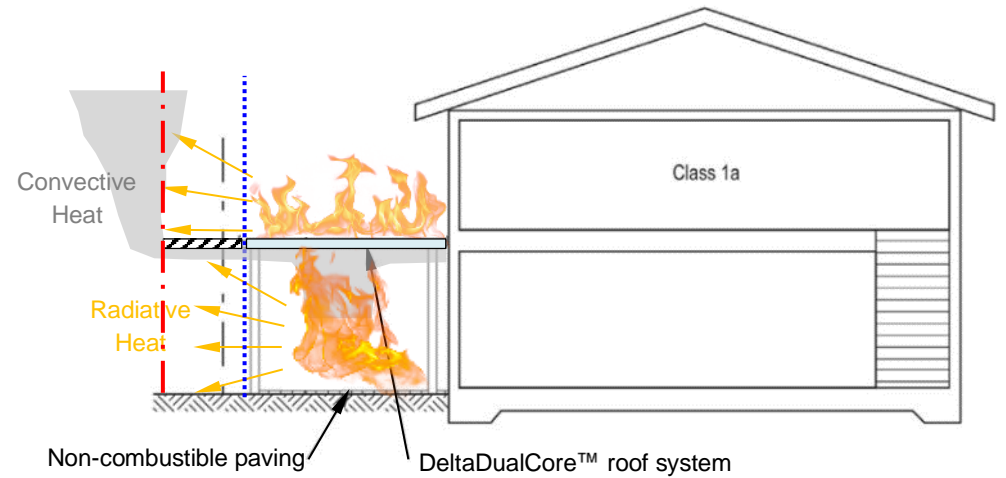

Combustible roof
 Non-combustible roof
 Site Boundary
 900 mm set back from site boundary

PERFORMANCE SOLUTION CASE

THE DTS PROVISIONS DO NOT RESTRICT FIRE SPREAD FROM THE CLASS 10a STRUCTURE TO THE ASSOCIATED CLASS 1 HOUSE. AS SUCH, FIRE SPREAD TO THE ATTACHED HOUSE IS NOT CONSIDERED.

Figure 4-11. Fire scenario 1: Mechanisms for heat transfer from a fire below the Class 10a roof covering within 900 mm of the site boundary.

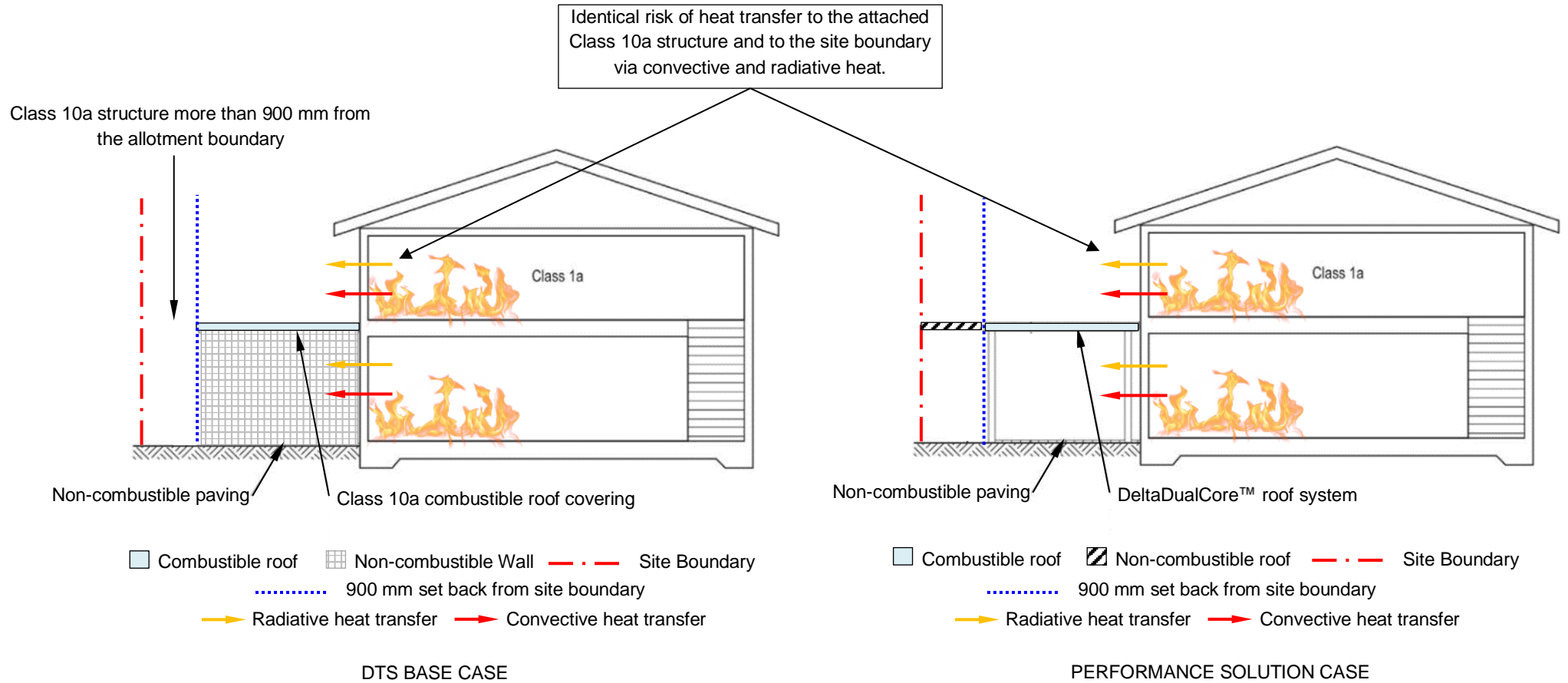
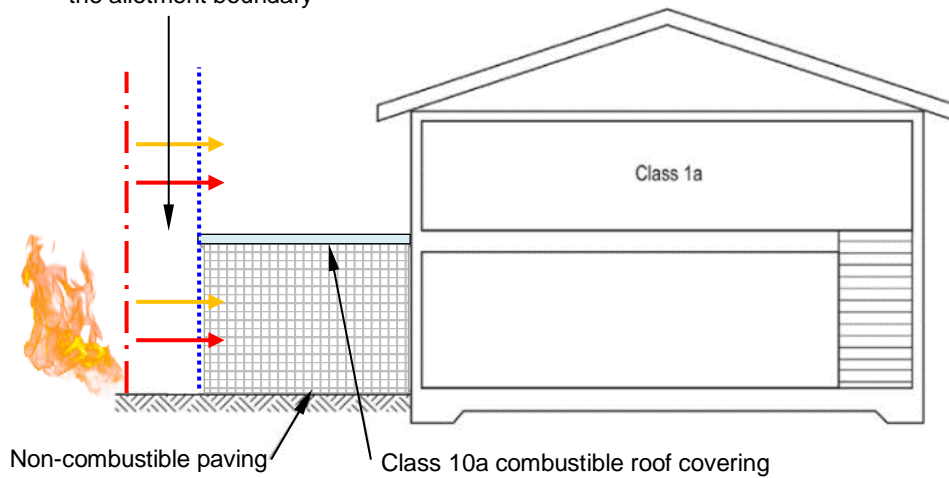

Figure 4-12. Fire scenario 2: Mechanisms for heat transfer from a Class 1 house fire to the attached Class 10a structure and site boundary.

Class 10a structure more than 900 mm from the allotment boundary



- Combustible roof ▣ Non-combustible Wall - · - Site Boundary
- 900 mm set back from site boundary
- Radiative heat transfer → Convective heat transfer

DTS BASE CASE

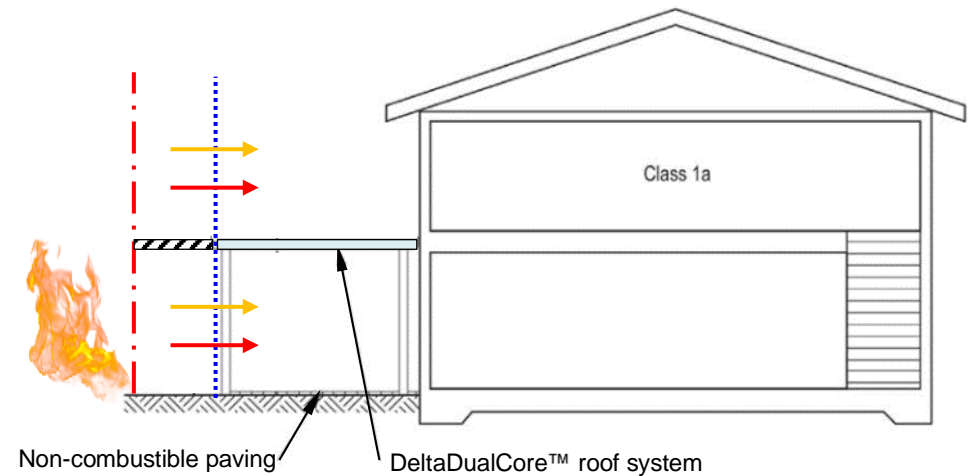

- Combustible roof ▨ Non-combustible roof - · - Site Boundary
- 900 mm set back from site boundary
- Radiative heat transfer → Convective heat transfer

PERFORMANCE SOLUTION CASE

Figure 4-13. Fire scenario 3: Mechanisms for heat transfer from the allotment boundary to the Class 10a structure and attached house.

4.8.2.1 Fire Scenario 1: Fire Within or Below the Class 10a Structure

As can be seen from Figure 4-11, the radiative component of heat transfer to the site boundary (which includes design fire 1 in accordance with Section 4.7.1.1) is no worse for the performance solution case than for the DtS base case. However, due to the awning extending all the way to the site boundary, convective heat may spill directly to the site boundary which could increase the risk of fire spread to the neighbouring allotment.

To assess the combination of convective and radiative heat transfer to the site boundary for the DeltaDualCore™ system (performance solution case) compared to the DtS base case, an FDS analysis is undertaken in Appendix B.

As demonstrated by the results given in Appendix B, the DeltaDualCore™ system when installed to the requirements given in Section 4.4 does not present a greater hazard of fire spread to the site boundary than the DtS base case. Thus, the performance requirement is satisfied for this fire scenario.

4.8.2.2 Fire Scenario 2: Fire Within the Class 1 House

As shown in Figure 4-12, in both the DtS case and in the performance solution case,

- The Class 10a structure attached directly to the Class 1 building is combustible.
- The Class 10a structure is attached to an identical Class 1 building with identical fire load.
- The Class 1 building is located an identical distance from the site boundary.

Thus, the potential for fire spread from the Class 1 building to the Class 10a structure is identical for the DtS base case and performance solution case. Heat transfer from the Class 1 building to the site boundary is also identical for the DtS base case and performance solution case. Any difference in the risk of fire spread from the subject allotment to the neighbouring allotment is therefore contributable to the Class 10a structure itself.

The assessment outlined in Appendix B therefore applies and the results demonstrate that the DeltaDualCore™ system when installed to the requirements given in Section 4.4 does not present a greater hazard of fire spread to the site boundary than the DtS base case. Thus, the performance requirement is satisfied for this fire scenario.

4.8.2.3 Fire Scenario 3: Fire Spread from the Site Boundary to the Class 10a Structure

In this case the site boundary forms the fire source feature as discussed in Section 4.7.1.3. The incident radiation on the nearest point of the combustible roof system (point F in Figure 4-14) is considered for both the DtS base case and performance solution case. As the performance solution case has a non-combustible component within 900 mm of the site boundary, this may to some degree shield point F from radiation emitted from the site boundary. However, radiation received at point F for the performance solution case is at least equivalent to or less severe than the DtS base case.

However, heat conduction through the steel components forming part of the non-combustible portion of the roof system that is within 900 mm of the site boundary provides an additional mechanism for heat transfer to the combustible portion of the roof system. Convective heat can dissipate to sky and is not a dominant mechanism for heat transfer from the boundary to the Class 10a structure and is therefore ignored.

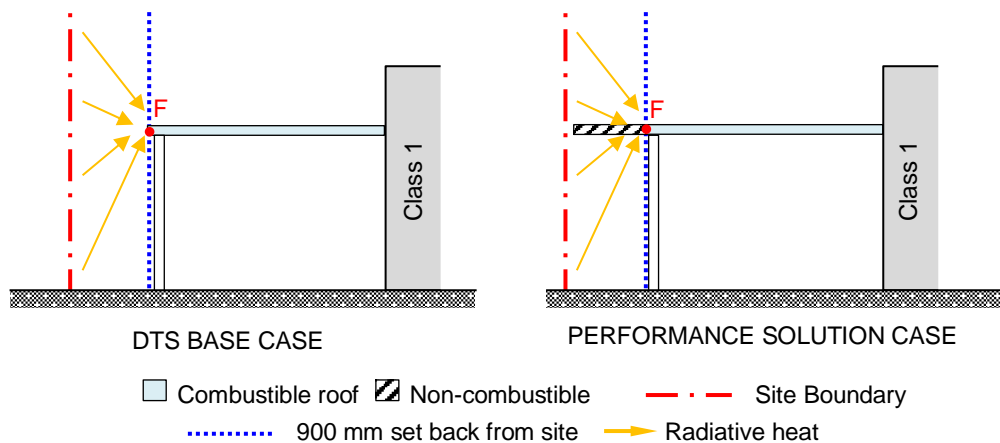

Figure 4-14. Radiative heat transfer from the site boundary to the nearest point of the combustible roof covering for the DtS base case and performance solution case (point F).

A 1-dimensional finite difference calculation is undertaken to assess the effect of conduction on heat transfer to the combustible portion of the roof system; refer to Appendix A. As shown in Figure 5-2, the results indicate that conductive heat attenuates quickly along the length of the steel rod and has no significant impact on the steel temperatures at a distance over 900 mm from the site boundary. The finite difference calculation assumes a solid rod with a cross section of 0.008 m² which far exceeds that of a lightweight roof purlin. As such the conduction assessment is conservative and conduction to a much lesser degree would be expected in a real fire condition.

Thus, conduction is not considered to present a dominant mechanism for heat transfer to the combustible component of the DeltaDualCore™ roof system.

The risk of fire spread from the site boundary to the combustible portion of the roof system is therefore demonstrated to be no worse than that of the DtS base case, therefore satisfying the performance requirement.

4.8.2.4 Supplementary Discussion

NCC 9.2.9(4) permits combustible fascia's within 900mm but not closer than 450 mm from the site boundary as shown in Figure 4-15. Furthermore, non-combustible plumbing fixtures may be fitted within the 450 mm region as it is not considered to increase the risk of fire spread between neighbouring building due to it being non-combustible.

This forms the basis of the proposed performance solution. The portion of the roof system which is combustible is suitably separated from the site boundary to the degree necessary to reduce the risk of fire spread between buildings. The non-combustible portion of the roof which (as demonstrated in Sections 4.8.2.1 to 4.8.2.3) does not increase the risk of fire spread between buildings and is therefore permitted to extend to the site boundary.

The assessment considers the potential for fire spread from the site boundary to a combustible component of the roof system and vice versa. The thickness of the core material of each roof panel does not impact the likelihood of fire spread from the site boundary to the roof, or from the roof to the site boundary (as the thickness would be identical for the DtS base case and the performance solution case). As such, increasing or decreasing the roof panel thickness does not increase the risk of fire spread between buildings when compared to the DtS base case. As such, the assessment is independent of the thickness of the core material used in the roof system.

The assessment has demonstrated achievement of performance requirement H3P1.

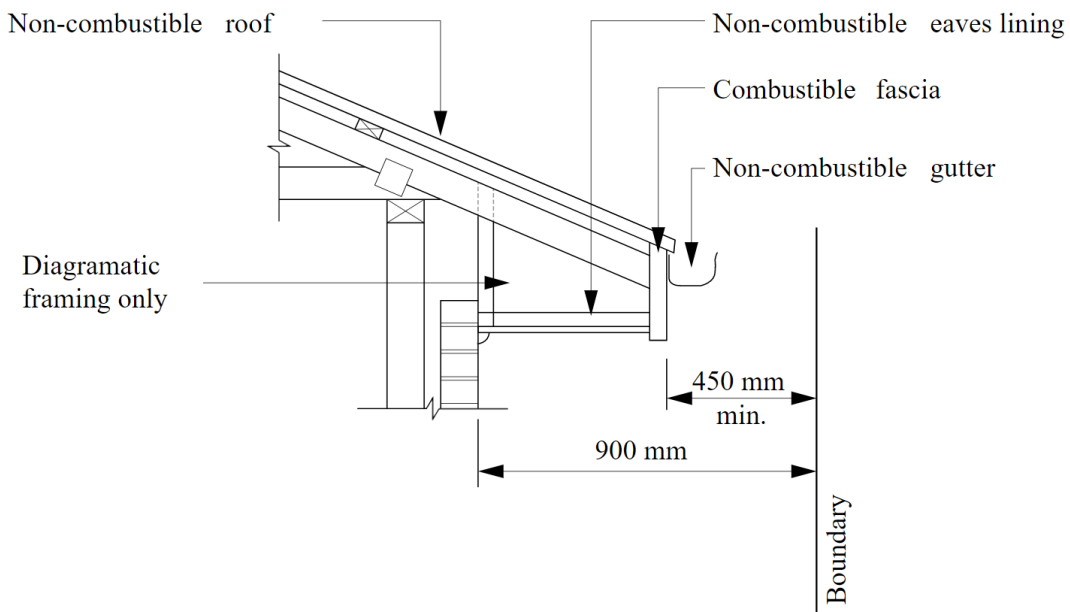

Figure 4-15. Combustible fascia permitted up to but not closer than 450 mm to an allotment boundary (NCC Figure 9.2.9a).

4.9 Conclusion and Compliance

This fire engineering report confirms that the DeltaTrim™ DualCore™ & DeltaOrb™ DualCore™ panels which have;

- A width of 1000 mm,
- cut to length (1800 mm minimum),
- thickness ranging from 75 mm -150 mm,
- a core consisting of two parts including one part mineral wool (at least 900 mm in length and comprising the full width of panel measured from the edge of the panel) and remaining part fire retardant SL Grade Expanded Polystyrene (EPS),
- top skin consisting of 0.45 mm Colorbond Steel and bottom skin consisting of 0.55 mm UniCote Steel,

meet the performance requirements of H3P1(1) Volume 2, NCC 2022 when installed in accordance with the DeltaDualCore™ brochure version V27.08.21 and Section 4.4 of this report as a Class 10a structure (awning or patio) attached or adjacent to a Class 1a building positioned directly adjacent to the site boundary (i.e. less than 900 mm from the site boundary).

The comparative assessment has demonstrated qualitatively and quantitatively that the DeltaDualCore™ system (when installed to the requirements of Section 4.4) does not increase the risk of fire spread from or to an associated Class 1 building when compared to the DtS base case.

Performance requirement H3P1(1) is satisfied. The assessment is compliant in accordance with A2G2(1)(b) and A2G2(2)(d).

5 References

ABCB National Construction Code 2022, Building Code of Australia – Housing Provisions Standard.

ABCB National Construction Code 2022, Building Code of Australia – Volume 2.

AS3600:2018 - Concrete Structures

Cengel A. Y., Ghajar J. A., 2011. Heat and Mass Transfer Fundamentals and Applications. Fourth Edition.

Cladding Materials Library. 2021. *Cladding Materials Library*. [online] Available at: [<https://claddingmaterialslibrary.com/>](https://claddingmaterialslibrary.com/) [Accessed 24 February 2021].

CSIRO “ Australian Fire Incident Statistics 1992 - 1993” Technical Report 95/1, 1995

Dowling VP and Ramsay GC, “Building Fire Scenarios – An Analysis of Fire Incident Statistics”, Technical Report FCRC – TR 96-02, 1996.

Home Office, "Fire Statistics United Kingdom, 2002", 2004, Statistics Division 3, Research and Statistics Department, 50 Queen Anne's Gate, London, SW1H 9AT.

SFPE Handbook (2003), “The SFPE Handbook of Fire Protection Engineering”, 3rd edition, published by National Fire Protection Association and Society of Fire Protection Engineers US.

SFPE Handbook (2016), “The SFPE Handbook of Fire Protection Engineering”, 5th edition, published by Society of Fire Protection Engineers.

Sun, P., Bisschop, R., Niu, H. and Huang, X., 2020. A review of battery fires in electric vehicles. Fire technology, pp.1-50.

T. Alam, P Beever, “Flashover Fires – An Experimental Program”, CESARE Report 96-002, October 1996.

Appendix A Assessment of Heat Conduction Through a Steel Member

A.1 Introduction

A one-dimensional finite difference heat transfer calculation is undertaken to determine the temperature distribution through a steel purlin (approximated as a solid steel rod) when exposed on one face to a H3V3 fire source feature on the site boundary. The simplified model is shown in Figure 5-1.

The aim of the assessment is to establish whether conduction through a steel member along the non-combustible portion of the DeltaDualCore™ system may result in ignition of the EPS-FR component of the roof system.

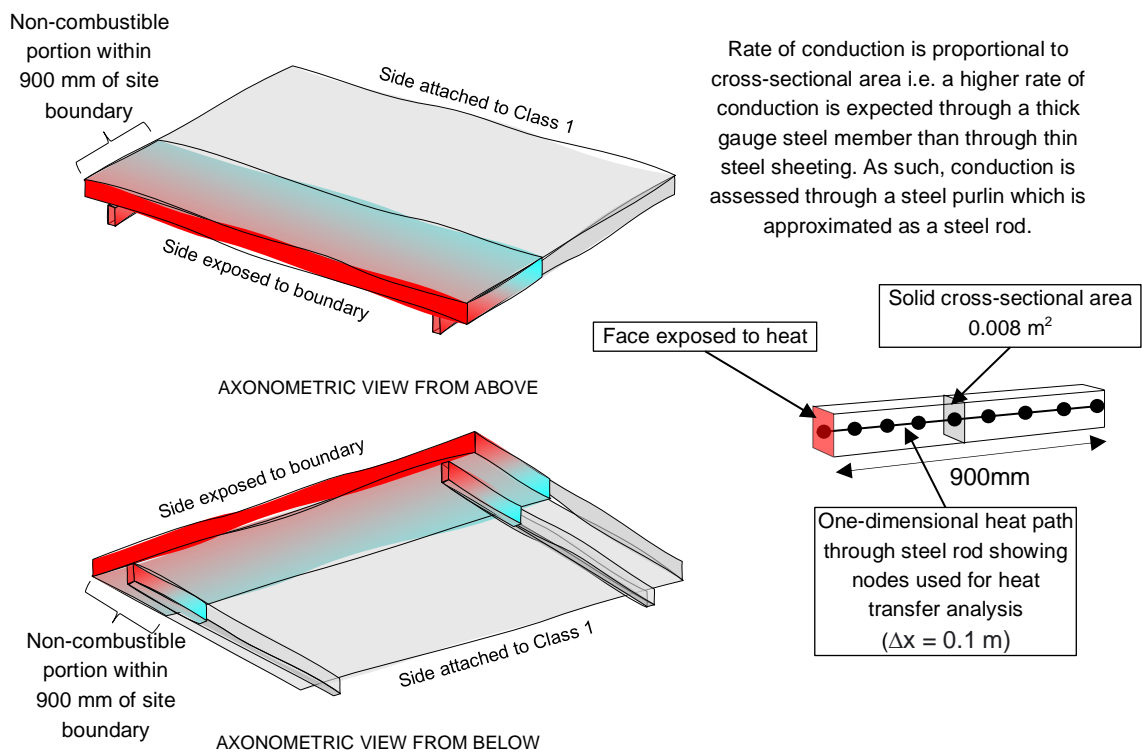

Figure 5-1. Finite Difference Heat Transfer Analysis Paths to assess heat transfer through a steel member via conduction.

A.2 Methodology

The finite difference heat transfer equation used for calculating the temperature distribution through the steel rod is given below:

$$T'_o = \left[\frac{k_s A (T_{n-1} - T_n)}{\delta x_{n,n-1}} + \frac{k_s A (T_{n+1} - T_n)}{\delta x_{n+1,n}} - hA(T_o - 20) - \varepsilon\sigma A(T_o^4 - 293^4) \right] \times \frac{\delta t}{\rho c A \delta x_o} + T_o$$

For the above equation the notation is defined as follows:

variables:

A	= aggregate cross-sectional area of steel rod along the heat path (m^2)
c	= specific heat (J/kgK)
k	= conductivity (W/mK)
T	= temperature ($^{\circ}C$)
t	= time (s)
x	= distance (m)
ρ	= density (kg/m^3)
h	= convective heat transfer coefficient ($W/m^2/K$)
ε	= emissivity value
σ	= Stefan-Boltzmann ($5.67 \times 10^{-8} W/m^2/K^4$)
prefix: δ	= small increment
subscripts:	
s	= metal (steel)
O	= node at which temperature is being determined
$n-1$	= previous time step of node O
$n+1$	= next time step of node O

Using a spreadsheet, the temperature distribution through the steel rod was solved. The results are given in Figure 5-2. The thermal properties adopted are given in Table 5-1. More detailed explanation for explicit finite difference analysis of heat transfer can be found in Cengel et al (2011).

Table 5-1. Material thermal properties (Drysdale 1999)

	Copper
Conductivity, k (W/mK)	45.8
Specific heat at constant pressure, c (J/kgK)	460
Density ρ (kg/m^3)	7850
Emissivity	0.7

A.2 Results & Conclusion

The temperature distribution through the steel rod after 60 minutes of exposure to standard fire is given in Figure 5-2.

The results indicate that conductive heat attenuates quickly along the length of the steel rod and has no significant impact on the steel temperatures at a distance over 900 mm from the site boundary.

Thus, conduction is not considered to present a dominant mechanism for heat transfer to the combustible component of the DeltaDualCore™ roof system.

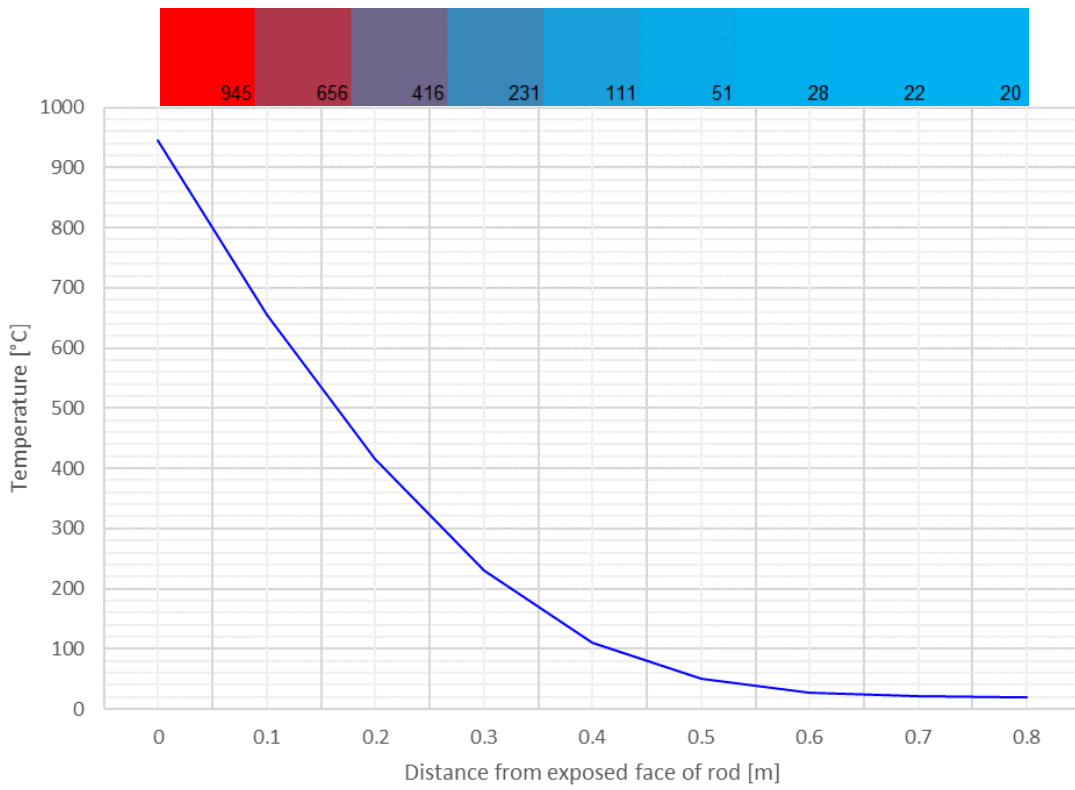

Figure 5-2. Temperature distribution through the steel rod after 60 minutes of exposure to standard fire.

Appendix B FDS Assessment

B.1 Introduction

An FDS analysis is undertaken to assess the combined heat transfer to the site boundary for the DeltaDualCore™ system when compared to the DtS base case.

B.2 Model Geometry

The model geometries for each of the three FDS models use are described in Figure 5-3, Figure 5-4 and Figure 5-5 and include:

1. Model 1: DtS base case.
2. Model 2: DeltaDualCore™ awning with equivalent dimensions to Model 1 (performance solution case).
3. Model 3: Sensitivity case where the width of the awning in Model 2 is increased by 100%.

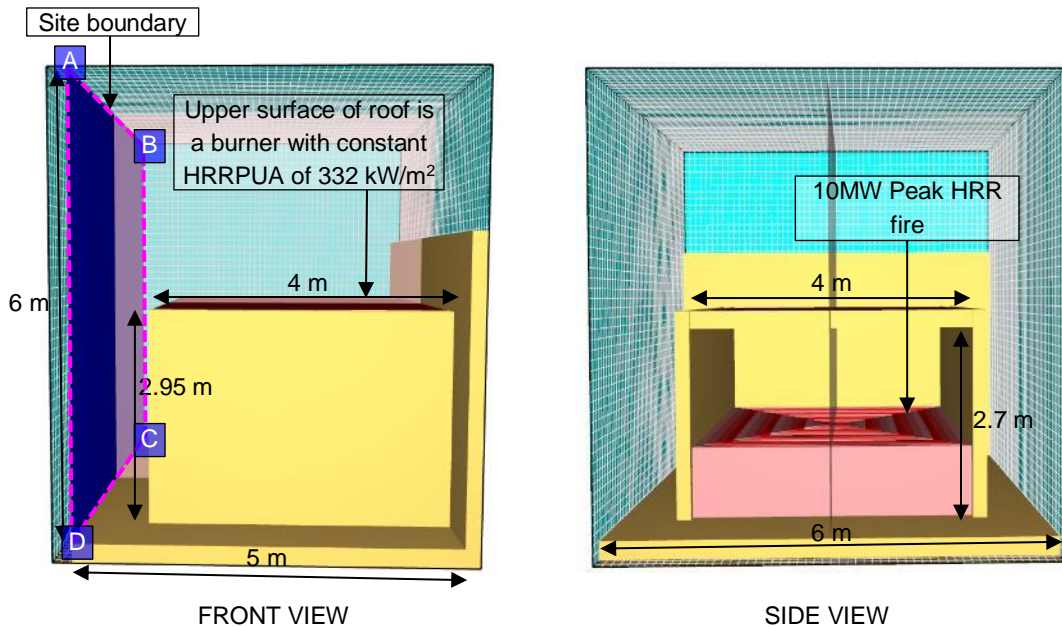

Figure 5-3. Model 1: Model geometry for DtS base case.

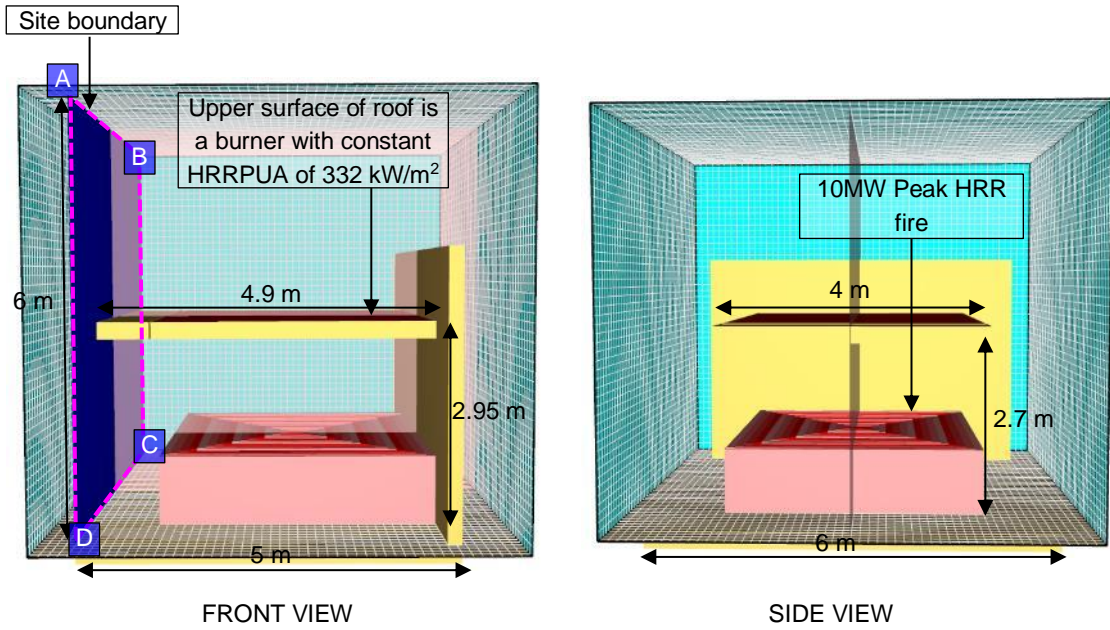

Figure 5-4. Model 2: Model geometry for a DeltaDualCore™ roof (equivalent dimensions to DtS base case) located directly adjacent to the site boundary.

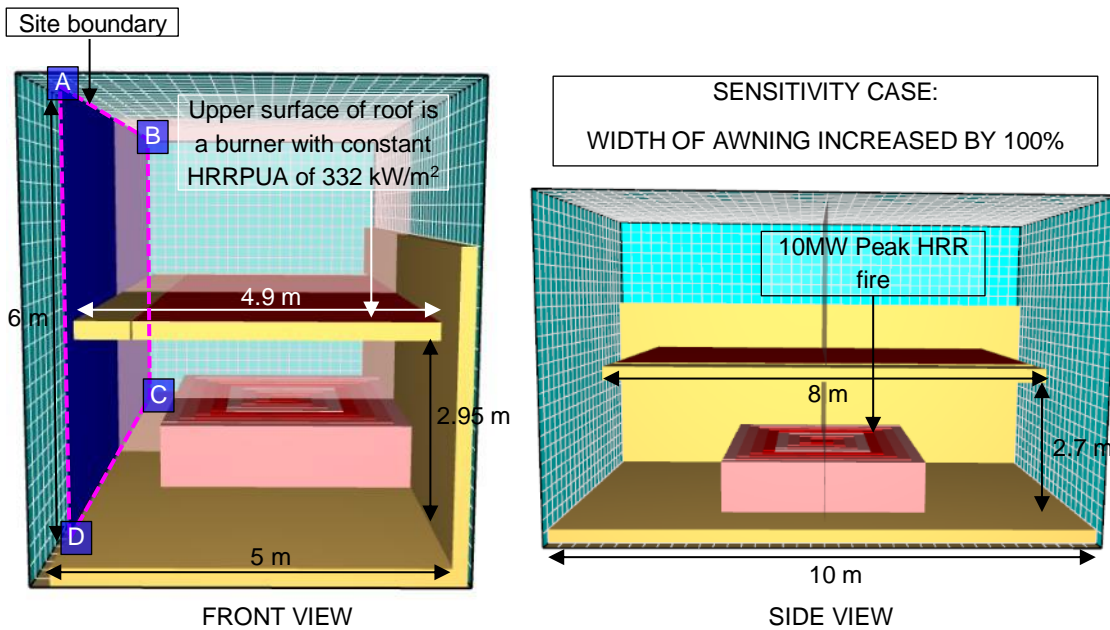

Figure 5-5. Model 3: Sensitivity Study - Model geometry for a DeltaDualCore™ roof assessing impact of awning width on heat transfer to the site boundary.

B.3 Design Fire

The design fire is taken as the combined fire load of an EPS core sandwich panel roof system and Design Fire 1 in accordance with Section 4.7.1.1.

For the EPS core roof system, a heat release rate per unit area (HRRPUA) of 332 kW/m² is adopted which has been derived from bench-scale fire testing that was conducted by the University of Queensland and is

detailed within the UQ Cladding Materials Library. Figure 5-6 indicates the measured HRRPUA of EPS when exposed to varying levels of heat flux. Conservatively, a constant HRRPUA of 332 kW/m² is used for the entire roof system (simulating the full upper surface of the roof burning at this peak HRRPUA continuously) as superimposed over Figure 5-6.

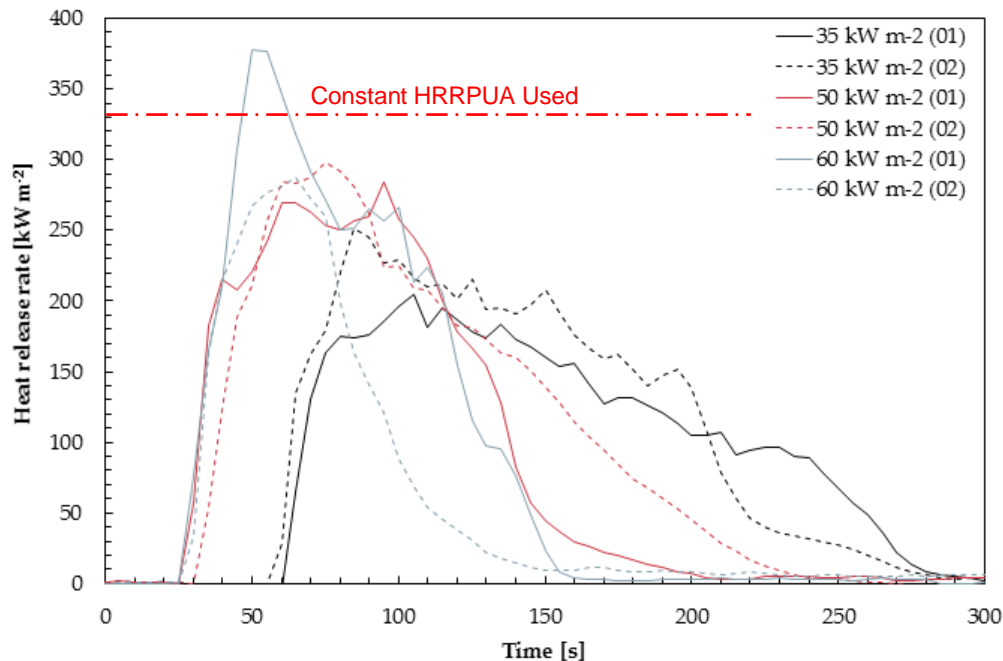

Figure 5-6. Heat release rate per unit area over time for EPS when tested with 35, 50, 60 and 80 kW/m² (from the UQ Cladding Materials Library).

B.4 Results & Conclusion

Results are shown in Figure 5-7, Figure 5-8 and Figure 5-9 which indicate the maximum adiabatic surface temperature (AST) and incident heat flux (IHF) on the site boundary when the fire is at steady state for each of the three models.

The results indicate that a much larger IHF and AST is reached on the site boundary for DtS base case when compared to the DeltaDualCore™ system with equivalent dimensions, or the sensitivity case in which the width of the awning is increased by 100%.

The sensitivity case indicates that increasing the width of the awning also increase the AST and IHF. With a 100% increase in width, AST increased by approximately 30% and IHF increased by approximately 100%. This indicates that the increase in widths has a greater impact on radiative heat transfer than it has on convective heat transfer to the boundary. This is largely attributable to the larger combustible roof. Convective heat emanating from the combustible roof fire can rise to the sky without affecting the site boundary. However, as would be expected the radiative component increases proportionally with an increase the overall fire size.

That said, both the equivalent case and sensitivity case resulted in AST and IHF far lower than the DtS case. As such, the combined heat transfer to the site boundary for the DeltaDualCore™ system is at least equivalent to or better than DtS base case.

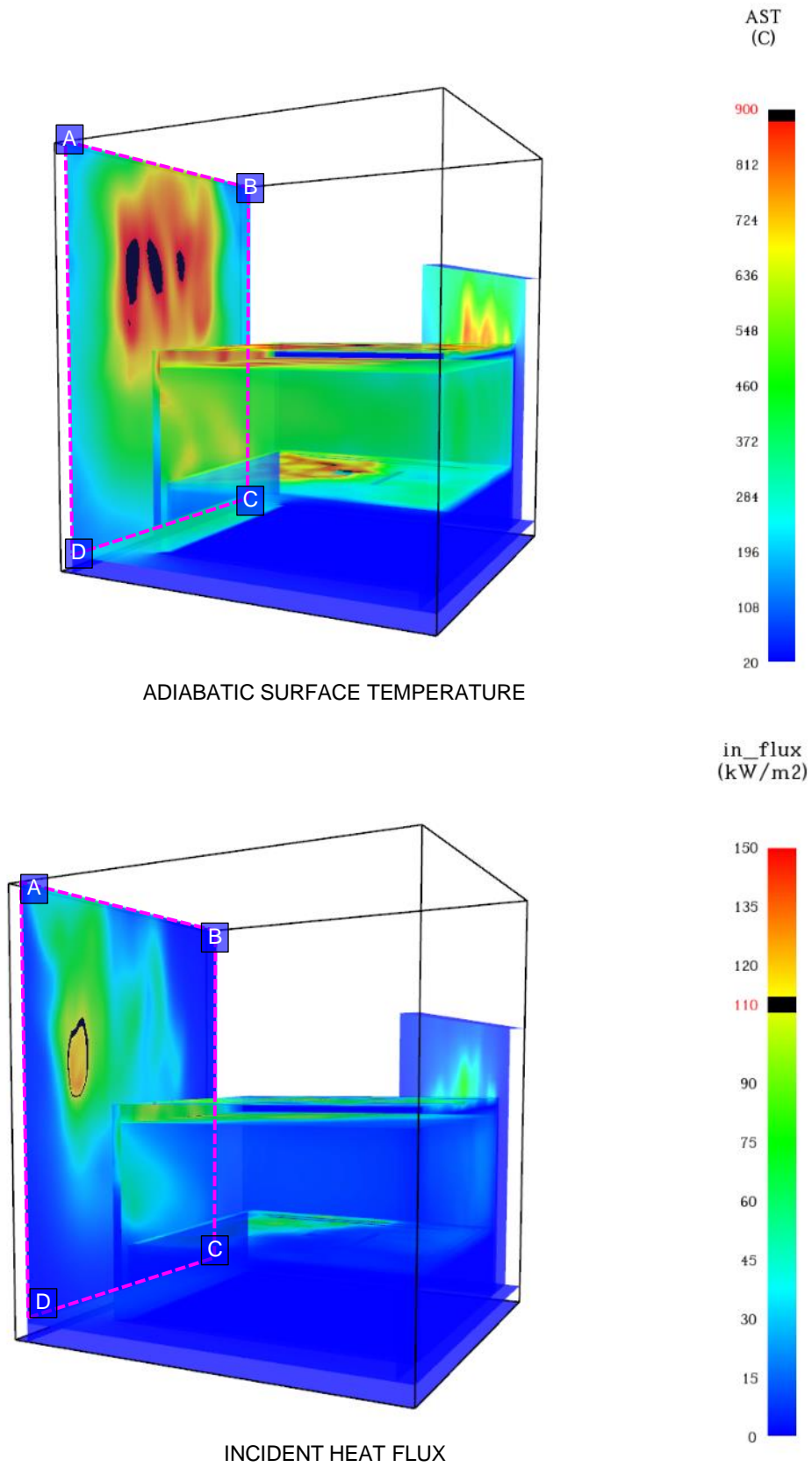
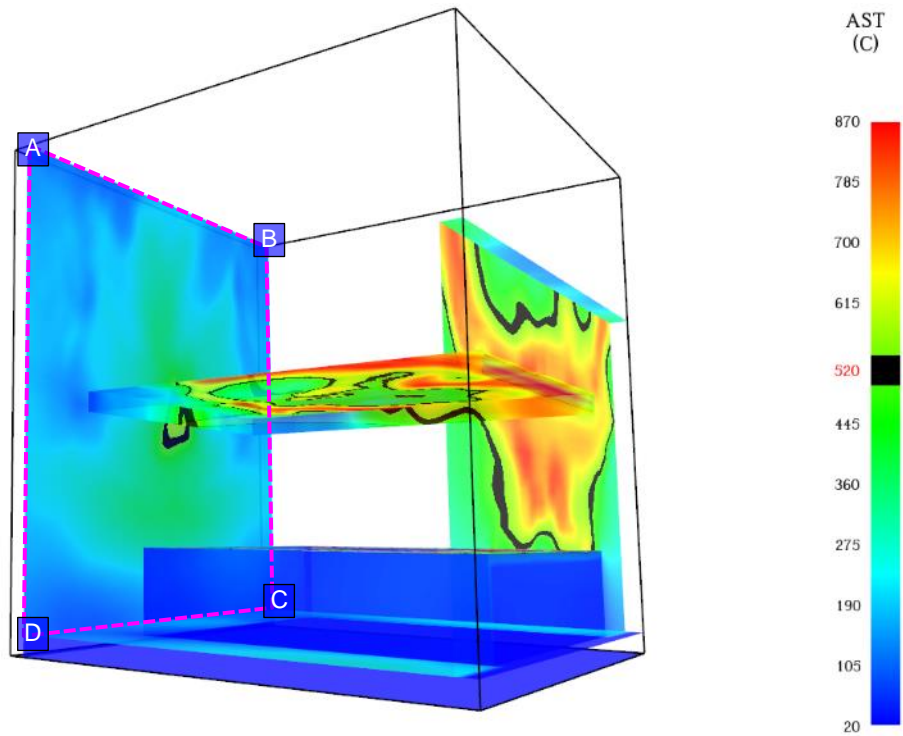
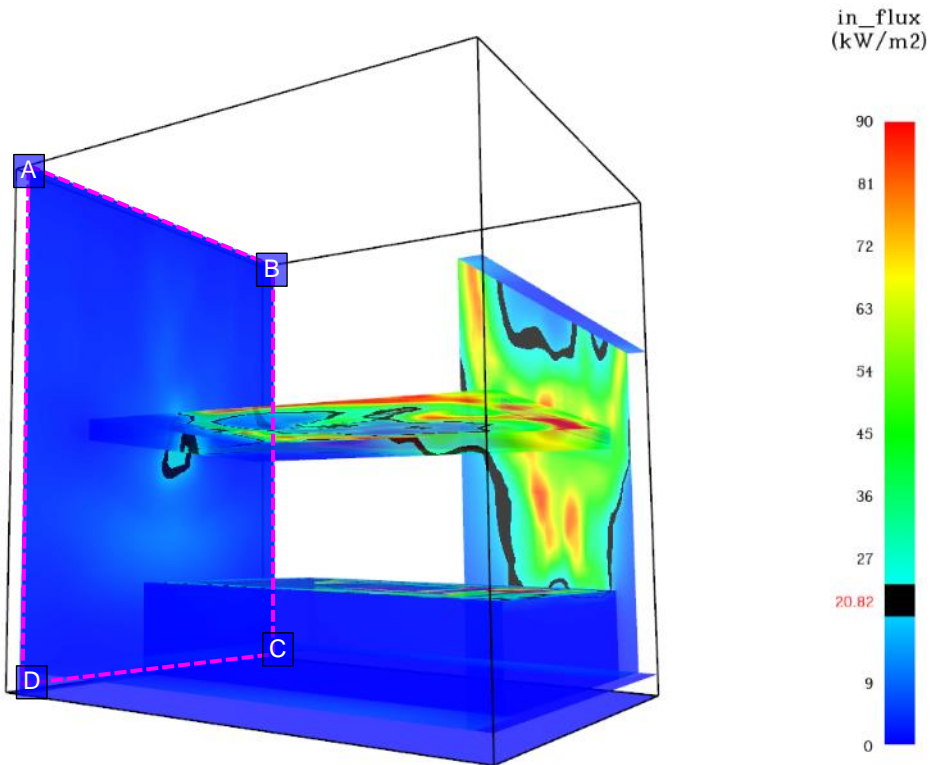

Figure 5-7. DtS base case results indicating adiabatic surface temperature (AST) and incident heat flux (IHF) on the site boundary (from Pyrosim Results).



ADIABATIC SURFACE TEMPERATURE



INCIDENT HEAT FLUX

Figure 5-8. Results for DeltaDualCore™ system with equivalent dimensions and fire to DtS base case indicating adiabatic surface temperature (AST) and incident heat flux (IHf) on the site boundary (from Pyrosim Results).

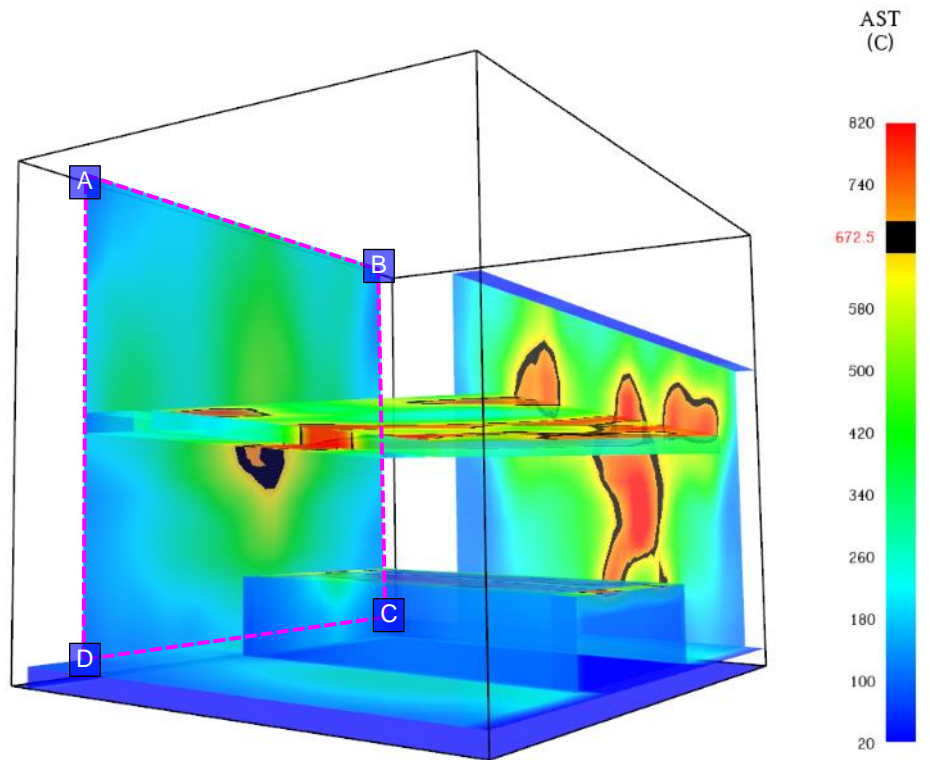

ADIABATIC SURFACE TEMPERATURE

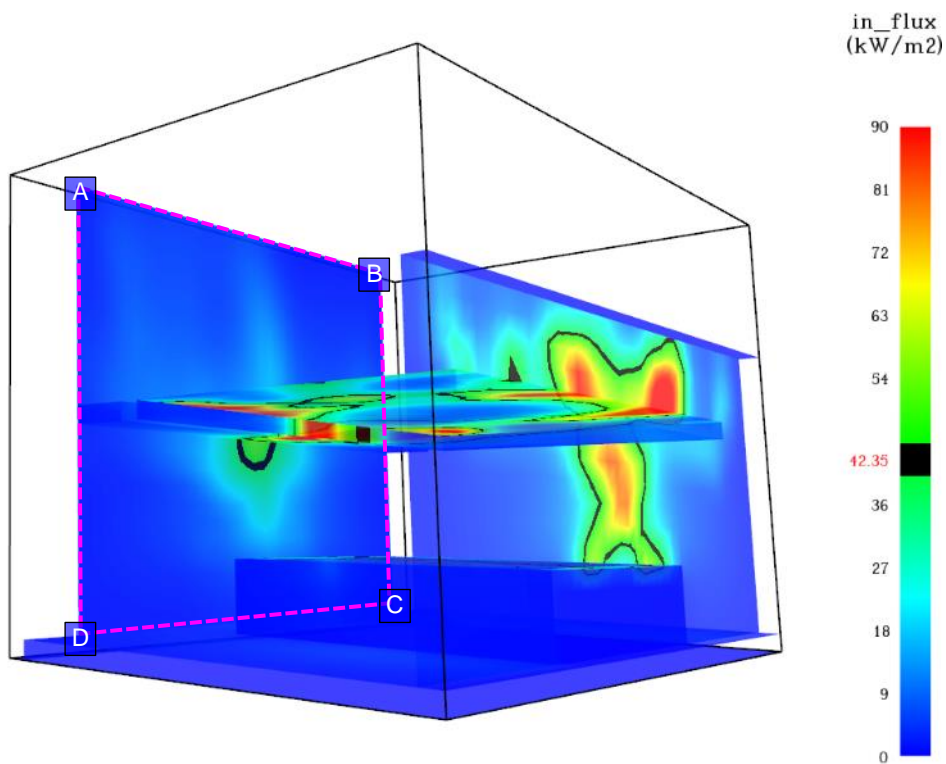

INCIDENT HEAT FLUX

Figure 5-9. Results for DeltaDualCore™ system sensitivity study with awning width increased by 100%, indicating adiabatic surface temperature (AST) and incident heat flux (IHF) on the site boundary (from Pyrosim Results).

B.5 FDS Grid sensitivity

A grid sensitivity check has been performed to evaluate the grid dependence of the models. FDS uses a Large Eddy Simulation (LES) model for computation. The grid size allows the sub-grid scale stress model to accurately compute the viscous stress of the flow field. The following formula, as detailed in the NIST Fire Dynamics Simulator (Version 5) User's Guide, can be used to measure how well the flow field within FDS modelling is resolved:

$D/\delta x$ where,

δx is the nominal size of a mesh cell

D is a characteristic fire diameter;

$$D = \left(\frac{\dot{Q}^*}{(\rho_\infty \times C_p \times T_\infty \times \sqrt{g})} \right)^{2/5}$$

Where: \dot{Q}^* (kW) is the heat release rate

ρ_∞ (kg/m³) is the density of ambient temperature – 1 kg/m³

C_p (kg/kg.K) is the specific heat of the gas – 1.0 kg/kg.K

T_∞ (K) is the ambient temperature – 293 K

g (m/s²) is the acceleration due to gravity – 9.81 m/s²

The grid size used in the FDS modelling is 0.125 for Models 1 & 2; and 0.25 for Model 3.

$\delta x = 0.125; 0.25$ m

HRR of 15 MW will be used to decide the grid size.

$Q = 15000$ kW, gives $D = 3.057$ m.

$D/\delta x = 3.057 / 0.125$

= 24.5

$D/\delta x = 3.057 / 0.25$

= 12.2

An acceptable value is considered to range from 4 to 16 with values higher than 16 presenting very high resolution. As stated in the FDS user guide (Pg. 45), the more cells spanning the characteristic fire the higher the resolution. These values are based on a validation study undertaken by the US Nuclear Regulatory Commission (McGrattan, Hill, Dreisbach, Joglar, Najafi, Peacock, Hamins, 2007).

The nominated grid sizes are within the acceptable range, with Models 1 and 2 being of very high resolution. Grid sensitivity is therefore acceptable to adequately resolve the plume field.

B.6 FDS Inputs

Key input parameters for FDS modelling are given below in Table 5-2.

Table 5-2 FDS key inputs

Input Parameter	Value
Ambient air temperature	20 °C
Radiative heat fraction from fire	30 %
Convective heat fraction from fire	70 %
Mass extinction coefficient	8,700m ² /kg (for flaming woods and plastics)
Fuel type	Polyurethane GM27

Appendix C AS1530.1 Test Certificates

C.1 Mineral Wool AS1530.1 Test Certificate

Certificate of Test

QUOTE No.: NC8391 REPORT No.: FNC12604

COMBUSTIBILITY TEST FOR MATERIALS IN ACCORDANCE WITH AS 1530.1-1994

TRADE NAME: Mineral Wool / Rock Wool

SPONSOR: Delta Panels Pty Ltd
731 Boundary Road
RICHLANDS QLD 4077
AUSTRALIA

DESCRIPTION OF TEST SAMPLE: The sponsor described the tested specimen as a mineral wool insulation slab comprised of a silicate fibres, alkaline oxide, alkali earth oxide, Bakelite synthetic thermosetting resin binder and mineral oil.

Nominal thickness: 50 mm
Nominal density: 100 kg/m³
Colour: brown

TEST PROCEDURE: Five (5) samples were tested in accordance with Australian Standard 1530 Methods for fire tests on building materials, components and structures, Part 1- 1994: Combustibility Test for Materials.

An alternative suitable insulating material was used to fill the annular space between the furnace tubes, as specified in Clause 4.2 of ISO 1182:2010.

RESULTS: The following calculated results were obtained, refer also to Summary of measurements:

Arithmetic mean	$= \frac{\Sigma \text{results}}{5}$
Mean furnace thermocouple temperature rise (°C)	26.37
Mean specimen centre thermocouple temperature rise (°C)	253.80
Mean specimen surface thermocouple temperature rise (°C)	36.60
Mean duration of sustained flaming (s)	0
Mean mass loss (%)	6.04

DESIGNATION: The material is NOT deemed combustible according to the test criteria specified in Clause 3.4 of AS 1530.1-1994.

These test results relate only to the behaviour of the test specimens of the material under the particular conditions of the test and they are not intended to be the sole criterion for assessing the potential fire hazard of the material in use.

DATE OF TEST: 8 July 2020

Issued on the 24th day of July 2020 without alterations or additions.

 Faustin Molina
 Testing Officer

 Stephen Smith
 Team Leader, Reaction to Fire & Façade Fire Laboratory

End of Report

Copyright CSIRO 2020 ©. Copying or alteration of this report without written authorisation from CSIRO is forbidden.

 NATA Accredited Laboratory
 Number: 165
 Corporate Site No 3625
 Accredited for compliance with ISO/IEC 17025 - Testing.

Page 1 of 2

CSIRO INFRASTRUCTURE TECHNOLOGIES

14 Julius Avenue, Riverside Corporate Park, North Ryde NSW 2113 AUSTRALIA
Telephone: 61 2 9490 5444 Facsimile: 61 2 9490 5555 www.csiro.au



SUMMARY OF MEASUREMENTS AND OBSERVATIONS OF SAMPLES UNDER TEST C12604

Parameters	Symbol or expression	Unit symbol	Sample Number				
			1	2	3	4	5
Initial specimen mass	m_{si}	g	7.52	8.15	7.09	7.82	8.87
Final specimen mass	m_{sf}	g	7.03	7.58	6.49	7.81	8.15
Mass loss	$\Delta m = \frac{M_{si} - M_{sf}}{M_{si}} \times 100$	%	6.52	6.99	8.46	0.13	8.12
Total duration of sustained flaming	Cumulative total of duration of flaming*	s	0	0	0	0	0
Initial furnace thermocouple temperature	T_{fi}	°C	748	747	746	754	748
Maximum furnace thermocouple temperature	T_{fm}	°C	816	802	818	803	798
Final furnace thermocouple temperature	T_{ff}	°C	782	781	785	782	775
Furnace thermocouple temperature rise	$\Delta T_f = T_{fm} - T_{ff}$	°C	34	21	33	21	23
Maximum specimen centre thermocouple temperature	T_{cm}	°C	1017	994	1039	1015	1049
Final specimen centre thermocouple temperature	T_{cf}	°C	762	762	776	773	772
Specimen centre thermocouple temperature rise	$\Delta T_c = T_{cm} - T_{cf}$	°C	255	232	263	242	277
Maximum specimen surface thermocouple temperature	T_{sm}	°C	816	818	829	835	834
Final specimen surface thermocouple temperature	T_{sf}	°C	780	785	790	801	793
Specimen surface thermocouple temperature rise	$\Delta T_s = T_{sm} - T_{sf}$	°C	36	33	39	34	41
Test duration	-	min	40	30	55	30	30

- Any individual duration flaming less than 5 seconds was discarded

End of Test Certificate

Page 2 of 2

CSIRO INFRASTRUCTURE TECHNOLOGIES

14 Julius Avenue, Riverside Corporate Park, North Ryde NSW 2113 AUSTRALIA
 Telephone: 61 2 9490 5444 Facsimile: 61 2 9490 5555 www.csiro.au



C.2 Coated Sheet Steel (Low Carbon Steel) AS1530.1 Test Certificates

Certificate of Test

QUOTE No.: NC8205

REPORT No.: FNC12440

COMBUSTIBILITY TEST FOR MATERIALS IN ACCORDANCE WITH AS 1530.1-1994

TRADE NAME: Low Carbon Steel Manufactured by Bluescope Australia

SPONSOR: Bluescope Steel Limited
Five Islands Road
Sirius Building (#51)
PORT KEMBLA NSW 2505
AUSTRALIA

DESCRIPTION OF TEST SAMPLE: The sponsor described the tested specimen as low carbon steel.

Nominal thickness: 4.38 mm (loose laid to form 50 mm)
Nominal density: 7850 kg/m³
Colour: grey

TEST PROCEDURE: Five (5) samples were tested in accordance with Australian Standard 1530 Methods for fire tests on building materials, components and structures, Part 1- 1994: Combustibility Test for Materials.

An alternative suitable insulating material was used to fill the annular space between the furnace tubes, as specified in Clause 4.2 of ISO 1182:2010.

RESULTS: The following calculated results were obtained, refer also to Summary of measurements:

Arithmetic mean	$= \frac{\Sigma \text{results}}{5}$
Mean furnace thermocouple temperature rise (°C)	0.10
Mean specimen centre thermocouple temperature rise (°C)	0.06
Mean specimen surface thermocouple temperature rise (°C)	0.32
Mean duration of sustained flaming (s)	0
Mean mass loss (%)	0.06

DESIGNATION: The material is **NOT** deemed combustible according to the test criteria specified in Clause 3.4 of AS 1530.1-1994.

These test results relate only to the behaviour of the test specimens of the material under the particular conditions of the test and they are not intended to be the sole criterion for assessing the potential fire hazard of the material in use.

DATE OF TEST: 27 August 2019

Issued on the 9th day of September 2019 without alterations or additions.

Faustin Molina
Testing Officer



Brett Roddy
Group Leader, Fire Testing and Assessments

Copyright CSIRO 2019 ©. Copying or alteration of this report without written authorisation from CSIRO is forbidden.



NATA Accredited Laboratory
Number: 165
Corporate Site No 3625

Accredited for compliance with ISO/IEC 17025 - Testing.

Page 1 of 2

CSIRO INFRASTRUCTURE TECHNOLOGIES

14 Julius Avenue, Riverside Corporate Park, North Ryde NSW 2113 AUSTRALIA
Telephone: 61 2 9490 5444 Facsimile: 61 2 9490 5555 www.csiro.au



SUMMARY OF MEASUREMENTS AND OBSERVATIONS OF SAMPLES UNDER TEST C12440

Parameters	Symbol or expression	Unit symbol	Sample Number				
			1	2	3	4	5
Initial specimen mass	m_{si}	g	540.98	543.87	544.14	541.96	543.60
Final specimen mass	m_{sf}	g	540.82	543.84	544.00	541.15	543.21
Mass loss	$\Delta m = \frac{M_{si} - M_{sf}}{M_{si}} \times 100$	%	0.03	0.01	0.03	0.15	0.07
Total duration of sustained flaming	Cumulative total of duration of flaming*	s	0	0	0	0	0
Initial furnace thermocouple temperature	T_{fi}	°C	747	753	751	751	751
Maximum furnace thermocouple temperature	T_{fm}	°C	782	775	781	779	780
Final furnace thermocouple temperature	T_{ff}	°C	782	775	781	779	780
Furnace thermocouple temperature rise	$\Delta T_f = T_{fm} - T_{ff}$	°C	0	0	1	0	0
Maximum specimen centre thermocouple temperature	T_{cm}	°C	766	763	763	769	771
Final specimen centre thermocouple temperature	T_{cf}	°C	766	763	763	769	771
Specimen centre thermocouple temperature rise	$\Delta T_c = T_{cm} - T_{cf}$	°C	0	0	0	0	0
Maximum specimen surface thermocouple temperature	T_{sm}	°C	770	764	766	771	768
Final specimen surface thermocouple temperature	T_{sf}	°C	769	764	765	771	768
Specimen surface thermocouple temperature rise	$\Delta T_s = T_{sm} - T_{sf}$	°C	1	0	1	0	0
Test duration	-	min	105	85	75	85	85

* Any individual duration flaming less than 5 seconds was discarded

End of Test Certificate

Page 2 of 2

CSIRO INFRASTRUCTURE TECHNOLOGIES

14 Julius Avenue, Riverside Corporate Park, North Ryde NSW 2113 AUSTRALIA
Telephone: 61 2 9490 5444 Facsimile: 61 2 9490 5555 www.csiro.au



Appendix D AS1530.3 Test Certificates

D.1 DeltaOrb™ Facings Applied to EPS-FR Core AS1530.3 Test Certificate

AWTA PRODUCT TESTING

Australian Wool Testing Authority Ltd - trading as AWTA Product Testing
A.B.N 43 006 014 106

1st Floor, 191 Racecourse Road, Flemington, Victoria 3031
P.O Box 240, North Melbourne, Victoria 3051
Phone (03) 9371 2400 Fax (03) 9371 2499

TEST REPORT

Client : Delta Panels Pty Ltd
2828 Ipswich Road
Darra QLD 4076

Test Number : 19-003621
Issue Date : 30/07/2019
Print Date : 30/07/2019

Sample Description Clients Ref : "DeltaOrb-EPS-FR"
Rigid Panel
End Use : Insulated Building Panel
Nominal Composition : Pre-painted steel skins bonded to an expanded polystyrene core with fire retardant
Nominal Mass per Unit Area/Density : 13.5kg/m3
Nominal Thickness : 100mm

AS/NZS 1530.3-1999

Methods for Fire Tests on Building Materials, Components and Structures Part 3: Simultaneous Determination of Ignitability, Flame Propagation, Heat Release and Smoke Release

Face tested: Face
Date tested: 30/07/2019

	Standard Error	Mean
Ignition time	Nil	Nil min
Flame propagation time	Nil	Nil sec
Heat release integral	Nil	Nil kJ/m ²
Smoke release, log d	0.0862	-1.7720
Optical density, d		0.0185 / metre
Number of specimens ignited:		0
Number of specimens tested:		6
Regulatory Indices:		
Ignitability Index		0 Range 0-20
Spread of Flame Index		0 Range 0-10
Heat Evolved Index		0 Range 0-10
Smoke Developed Index		2 Range 0-10

174448 37201

Page 1 of 2

© Australian Wool testing Authority Ltd
Copyright - All Rights Reserved



Accredited for compliance with ISO/IEC 17025 - Testing
- Chemical Testing
- Mechanical Testing
- Performance & Approvals Testing

: Accreditation No. 983
: Accreditation No. 985
: Accreditation No. 1356

Samples and their identifying descriptions have been provided by the client unless otherwise stated. AWTA Ltd makes no warranty, implied or otherwise, as to the source of the tested samples. The above test results relate only to the sample or samples tested. This document shall not be reproduced except in full and shall be rendered void if amended or altered. This document, the names AWTA Product Testing and AWTA Ltd may be used in advertising providing the content and format of the advertisement have been approved by the Managing Director of AWTA Ltd.



APPROVED SIGNATORY

MICHAEL A. JACKSON B.Sc.(Hons)
MANAGING DIRECTOR

0204/11/06

AWTA PRODUCT TESTING

Australian Wool Testing Authority Ltd - trading as AWTA Product Testing
 A.B.N 43 006 014 106
 1st Floor, 191 Racecourse Road, Flemington, Victoria 3051
 P.O Box 240, North Melbourne, Victoria 3051
 Phone (03) 9371 2400 Fax (03) 9371 2499

TEST REPORT

Client : Delta Panels Pty Ltd
 2828 Ipswich Road
 Darra QLD 4076

Test Number : 19-003621
 Issue Date : 30/07/2019
 Print Date : 30/07/2019

These results only apply to the specimen mounted, as described in this report. The result of this fire test may be used to directly assess fire hazard, but it should be recognised that a single test method will not provide a full assessment of fire hazard under all fire conditions.

Ignition is initiated by a pilot flame that is held near, but does not touch the specimen. A material that does not ignite during the standard test may ignite if contacted with a pilot flame during the test.

Each test specimen had an unattached backing of 4.5mm thick fibre reinforced cement board.

Each test specimen was clamped in four places.

174448

37201

Page 2 of 2

© Australian Wool testing Authority Ltd
 Copyright - All Rights Reserved



Accredited for compliance with ISO/IEC 17025 - Testing
 - Chemical Testing
 - Mechanical Testing
 - Performance & Approvals Testing

: Accreditation No. 983
 : Accreditation No. 985
 : Accreditation No. 1356



Samples and their identifying descriptions have been provided by the client unless otherwise stated. AWTA Ltd makes no warranty, implied or otherwise, as to the source of the tested samples. The above test results relate only to the sample or samples tested. This document shall not be reproduced except in full and shall be rendered void if amended or altered. This document, the names AWTA Product Testing and AWTA Ltd may be used in advertising providing the content and format of the advertisement have been approved by the Managing Director of AWTA Ltd.

0204/11/06

APPROVED SIGNATORY

MICHAEL A. JACKSON B.Sc. (Hons)
 MANAGING DIRECTOR

D.2 DeltaTrim™ Facings Bonded to EPS-FR Core AS1530.3 Test Certificate

AWTA PRODUCT TESTING

Australian Wool Testing Authority Ltd - trading as AWTA Product Testing
 A.B.N 43 006 014 106
 1st Floor, 191 Racecourse Road, Flemington, Victoria 3031
 P.O Box 240, North Melbourne, Victoria 3051
 Phone (03) 9371 2400 Fax (03) 9371 2499

TEST REPORT

Client : Delta Panels Pty Ltd
 2828 Ipswich Road
 Darra QLD 4076

Test Number : 19-003623
 Issue Date : 31/07/2019
 Print Date : 31/07/2019

Sample Description Clients Ref : DeltaTrim-EPS-FR
 Rigid Panel
 End Use : Insulated Building Panel
 Nominal Composition : Pre-painted steel skins bonded to an expanded polystyrene core with fire retardant
 Nominal Mass per Unit Area/Density : 13.5kg/m³
 Nominal Thickness : 100mm

AS/NZS 1530.3-1999

Methods for Fire Tests on Building Materials, Components and Structures Part 3: Simultaneous Determination of Ignitability, Flame Propagation, Heat Release and Smoke Release

Face tested:	Face		
Date tested:	31/07/2019		
	Standard Error	Mean	
Ignition time	Nil	Nil	min
Flame propagation time	Nil	Nil	sec
Heat release integral	Nil	Nil	kJ/m ²
Smoke release, log d	0.0579	-1.7469	
Optical density, d		0.0188	/ metre
Number of specimens ignited:		0	
Number of specimens tested:		6	
Regulatory Indices:			
Ignitability Index		0	Range 0-20
Spread of Flame Index		0	Range 0-10
Heat Evolved Index		0	Range 0-10
Smoke Developed Index		2	Range 0-10

174485

37203

Page 1 of 2

© Australian Wool testing Authority Ltd
 Copyright - All Rights Reserved



Accredited for compliance with ISO/IEC 17025 - Testing
 - Chemical Testing : Accreditation No. 983
 - Mechanical Testing : Accreditation No. 985
 - Performance & Approvals Testing : Accreditation No. 1356



Samples and their identifying descriptions have been provided by the client unless otherwise stated. AWTA Ltd makes no warranty, implied or otherwise, as to the source of the tested samples. The above test results relate only to the sample or samples tested. This document shall not be reproduced except in full and shall be rendered void if amended or altered. This document, the names AWTA Product Testing and AWTA Ltd may be used in advertising providing the content and format of the advertisement have been approved by the Managing Director of AWTA Ltd.

APPROVED SIGNATORY

MICHAEL A. JACKSON B.Sc.(Hons)
 MANAGING DIRECTOR

0204/11/06

AWTA PRODUCT TESTING

Australian Wool Testing Authority Ltd - trading as AWTA Product Testing

A.B.N 43 006 014 106

1st Floor, 191 Racecourse Road, Flemington, Victoria 3031

P.O Box 240, North Melbourne, Victoria 3051

Phone (03) 9371 2400 Fax (03) 9371 2499

TEST REPORT

Client : Delta Panels Pty Ltd
2828 Ipswich Road
Darra QLD 4076

Test Number : 19-003623
Issue Date : 31/07/2019
Print Date : 31/07/2019

These results only apply to the specimen mounted, as described in this report. The result of this fire test may be used to directly assess fire hazard, but it should be recognised that a single test method will not provide a full assessment of fire hazard under all fire conditions.

Ignition is initiated by a pilot flame that is held near, but does not touch the specimen. A material that does not ignite during the standard test may ignite if contacted with a pilot flame during the test.

Each test specimen had an unattached backing of 4.5mm thick fibre reinforced cement board.

Each test specimen was clamped in four places.

174485

37203

Page 2 of 2

© Australian Wool testing Authority Ltd
Copyright - All Rights Reserved



Accredited for compliance with ISO/IEC 17025 - Testing

- Chemical Testing
- Mechanical Testing
- Performance & Approvals Testing

: Accreditation No. 983
: Accreditation No. 985
: Accreditation No. 1356



Samples and their identifying descriptions have been provided by the client unless otherwise stated. AWTA Ltd makes no warranty, implied or otherwise, as to the source of the tested samples. The above test results relate only to the sample or samples tested. This document shall not be reproduced except in full and shall be rendered void if amended or altered. This document, the names AWTA Product Testing and AWTA Ltd may be used in advertising providing the content and format of the advertisement have been approved by the Managing Director of AWTA Ltd.

0204/11/06

APPROVED SIGNATORY

MICHAEL A. JACKSON B.Sc. (Hons)
MANAGING DIRECTOR

D.3 Coated Sheet Steel (Zincalume 0.5mm) AS1530.3 Test Certificate

Certificate of Test

Quote No.: NE7500

REPORT No.: FNE11602

AS/NZS 1530.3:1999 SIMULTANEOUS DETERMINATION OF IGNITABILITY, FLAME PROPAGATION, HEAT RELEASE AND SMOKE RELEASE

TRADE NAME: BlueScope ZINCALUME Steel

SPONSOR: Bluescope Steel Limited
Innovations Lab
Old Port Road
PORT KEMBLA NSW 2505
AUSTRALIA

DESCRIPTION OF SAMPLE:

The sponsor described the tested specimen as a metal-coated steel sheet with aluminium-zinc-magnesium alloy coating, resin coating and passivation layer on both sides.

Nominal thickness of steel sheet:	0.42 mm
Nominal thickness of aluminium-zinc-magnesium coating:	45 µm
Nominal thickness of passivation layer:	0.2 µm
Nominal thickness of resin layer:	3 µm
Nominal total thickness:	0.5 mm
Nominal total mass:	3.3 kg/m ²
Nominal total density:	7800 kg/m ³
Colour:	silver

TEST PROCEDURE: Six samples were tested in accordance with Australian Standard 1530, Method for fire tests on building components and structures, Part 3: Simultaneous determination of ignitability, flame propagation, heat release and smoke release, 1999. For the test, each sample was clamped to the specimen holder in four places.

RESULTS: The following means and standard errors were obtained:

Parameter	Mean	Standard Error
Ignition Time (min)	N/A	N/A
Flame Spread Time (s)	N/A	N/A
Heat Release Integral (kJ/m ²)	N/A	N/A
Smoke Release (log ₁₀ D)	-1.882	0.159

For regulatory purposes these figures correspond to the following indices:

Ignitability Index (0-20)	Spread of Flame Index (0-10)	Heat Evolved Index (0-10)	Smoke Developed Index (0-10)
0	0	0	2

The results of this fire test may be used to directly assess fire hazard, but it should be recognised that a single test method will not provide a full assessment of fire hazard under all fire conditions.

DATE OF TEST: 20 January 2016

Issued on the 3rd day of March 2016 without alterations or additions.

Heherson Alarde
Testing Officer

Brett Roddy
Team Leader, Fire Testing and Assessments

Copyright CSIRO 2015 ©. Copying or alteration of this report without written authorisation from CSIRO is forbidden.

NATA Accredited Laboratory
Number: 165
Corporate Site No 3625
Accredited for compliance with ISO/IEC 17025

CSIRO INFRASTRUCTURE TECHNOLOGIES

14 Julius Avenue, Riverside Corporate Park, North Ryde NSW 2113 AUSTRALIA
Telephone: 61 2 9490 5444 Facsimile: 61 2 9490 5555 www.csiro.au

D.4 Coated Sheet Steel (Colorbond 0.8mm) AS1530.3 Test Certificate

Certificate of Test

Quote No.: NE7500

REPORT No.: FNE11604

AS/NZS 1530.3:1999 SIMULTANEOUS DETERMINATION OF IGNITABILITY, FLAME PROPAGATION, HEAT RELEASE AND SMOKE RELEASE

TRADE NAME: BlueScope COLORBOND Metallic Steel Polyester

SPONSOR: Bluescope Steel Limited
Innovations Lab
Old Port Road
PORT KEMBLA NSW 2505
AUSTRALIA

DESCRIPTION OF SAMPLE:

The sponsor described the tested specimen as a polyester painted steel sheet with aluminium-zinc-magnesium alloy coating on both sides.

Nominal thickness of steel sheet:	0.70 mm
Nominal thickness of aluminium-zinc-magnesium coating:	30 µm
Nominal thickness of paint layer:	45 µm
Nominal total thickness:	0.8 mm
Nominal total mass:	5.5 kg/m ²
Nominal total density:	7700 kg/m ³
Colour:	metallic grey (Astro)

TEST PROCEDURE: Six samples were tested in accordance with Australian Standard 1530, Method for fire tests on building components and structures, Part 3: Simultaneous determination of ignitability, flame propagation, heat release and smoke release, 1999. For the test, each sample was clamped to the specimen holder in four places.

RESULTS: The following means and standard errors were obtained:

Parameter	Mean	Standard Error
Ignition Time (min)	N/A	N/A
Flame Spread Time (s)	N/A	N/A
Heat Release Integral (kJ/m ²)	N/A	N/A
Smoke Release (log ₁₀ D)	-1.535	0.086

For regulatory purposes these figures correspond to the following indices:

Ignitability Index (0-20)	Spread of Flame Index (0-10)	Heat Evolved Index (0-10)	Smoke Developed Index (0-10)
0	0	0	2

The results of this fire test may be used to directly assess fire hazard, but it should be recognised that a single test method will not provide a full assessment of fire hazard under all fire conditions.

DATE OF TEST: 10 February 2016

Issued on the 3rd day of March 2016 without alterations or additions.

Heherson Alarde
Testing Officer

Brett Roddy
Team Leader, Fire Testing and Assessments

Copyright CSIRO 2015 ©. Copying or alteration of this report without written authorisation from CSIRO is forbidden.

NATA Accredited Laboratory
Number: 165
Corporate Site No 3625
Accredited for compliance with ISO/IEC 17025

CSIRO INFRASTRUCTURE TECHNOLOGIES

14 Julius Avenue, Riverside Corporate Park, North Ryde NSW 2113 AUSTRALIA
Telephone: 61 2 9490 5444 Facsimile: 61 2 9490 5555 www.csiro.au

D.5 Coated Sheet Steel (Colorbond 0.7mm) AS1530.3 Test Certificate

Certificate of Test

Quote No.: NE7500

REPORT No.: FNE11603

AS/NZS 1530.3:1999 SIMULTANEOUS DETERMINATION OF IGNITABILITY, FLAME PROPAGATION, HEAT RELEASE AND SMOKE RELEASE

TRADE NAME: BlueScope COLORBOND Permagard steel

SPONSOR: Bluescope Steel Limited
Innovations Lab
Old Port Road
PORT KEMBLA NSW 2505
AUSTRALIA

DESCRIPTION OF SAMPLE: The sponsor described the tested specimen as a painted steel sheet with zinc coating on both sides.

Nominal thickness of steel sheet:	0.60 mm
Nominal thickness of zinc coating:	40 µm
Nominal thickness of paint layer:	30 µm
Nominal total thickness:	0.7 mm
Nominal total mass:	4.9 kg/m ²
Nominal total density:	7700 kg/m ³
Colour:	off-white (Surfmist - facing) / grey (backing)

TEST PROCEDURE: Six samples were tested in accordance with Australian Standard 1530, Method for fire tests on building components and structures, Part 3: Simultaneous determination of ignitability, flame propagation, heat release and smoke release, 1999. For the test, each sample was clamped to the specimen holder in four places.

RESULTS: The following means and standard errors were obtained:

Parameter	Mean	Standard Error
Ignition Time (min)	N/A	N/A
Flame Spread Time (s)	N/A	N/A
Heat Release Integral (kJ/m ²)	N/A	N/A
Smoke Release (log ₁₀ D)	-2.103	0.157

For regulatory purposes these figures correspond to the following indices:

Ignitability Index (0-20)	Spread of Flame Index (0-10)	Heat Evolved Index (0-10)	Smoke Developed Index (0-10)
0	0	0	1

The results of this fire test may be used to directly assess fire hazard, but it should be recognised that a single test method will not provide a full assessment of fire hazard under all fire conditions.

DATE OF TEST: 21 January 2016

Issued on the 3rd day of March 2016 without alterations or additions.

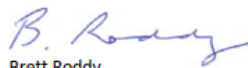
Heherson Alarde
Testing Officer

Brett Roddy
Team Leader, Fire Testing and Assessments

Copyright CSIRO 2015 ©. Copying or alteration of this report without written authorisation from CSIRO is forbidden.

NATA Accredited Laboratory
Number: 165
Corporate Site No 3625
Accredited for compliance with ISO/IEC 17025

CSIRO INFRASTRUCTURE TECHNOLOGIES

14 Julius Avenue, Riverside Corporate Park, North Ryde NSW 2113 AUSTRALIA
Telephone: 61 2 9490 5444 Facsimile: 61 2 9490 5555 www.csiro.au

D.6 Coated Sheet Steel (MagnaFlow) AS1530.3 Test Certificate

AWTA PRODUCT TESTING

Australian Wool Testing Authority Ltd - trading as AWTA Product Testing
 A.B.N 43 006 014 106
 1st Floor, 191 Racecourse Road, Flemington, Victoria 3031
 P.O Box 240, North Melbourne, Victoria 3051
 Phone (03) 9371 2400 Fax (03) 9371 2499

TEST REPORT

Client : Selection Steel Trading
 64-66 Ventura Place
 Dandenong South VIC 3175

Test Number : 19-002186
 Issue Date : 9/05/2019
 Print Date : 9/05/2019

Sample Description Clients Ref : "MagnaFlow"
 Coated steel panel
 Colour : Light Grey
 End Use : Roofing & Cladding
 Nominal Composition : Low carbon steel with metallic alloy coated substrate and organic top coating
 Nominal Mass per Unit Area/Density : 7850kg/m3

AS/NZS 1530.3-1999

Methods for Fire Tests on Building Materials, Components and Structures
 Part 3: Simultaneous Determination of Ignitability,
 Flame Propagation, Heat Release and Smoke Release

Face tested: Light Grey Face

Date tested: 09/05/2019

	Standard Error	Mean	
Ignition time	Nil	Nil	min
Flame propagation time	Nil	Nil	sec
Heat release integral	Nil	Nil	kJ/m ²
Smoke release, log d	0.0902	-1.3899	
Optical density, d		0.0445	/ metre
Number of specimens ignited:		0	
Number of specimens tested:		6	
Regulatory Indices:			
Ignitability Index		0	Range 0-20
Spread of Flame Index		0	Range 0-10
Heat Evolved Index		0	Range 0-10
Smoke Developed Index		3	Range 0-10

165141

35632

Page 1 of 2

© Australian Wool testing Authority Ltd
 Copyright - All Rights Reserved



Accredited for compliance with ISO/IEC 17025 - Testing
 - Chemical Testing
 - Mechanical Testing
 - Performance & Approvals Testing

: Accreditation No. 983
 : Accreditation No. 985
 : Accreditation No. 1356



Samples and their identifying descriptions have been provided by the client unless otherwise stated. AWTA Ltd makes no warranty, implied or otherwise, as to the source of the tested samples. The above test results relate only to the sample or samples tested. This document shall not be reproduced except in full and shall be rendered void if amended or altered. This document, the names AWTA Product Testing and AWTA Ltd may be used in advertising providing the content and format of the advertisement have been approved by the Managing Director of AWTA Ltd.

0204/11/06

APPROVED SIGNATORY

MICHAEL A. JACKSON B.Sc (Hons)
 MANAGING DIRECTOR

AWTA PRODUCT TESTING

Australian Wool Testing Authority Ltd - trading as AWTA Product Testing
 A.B.N 43 006 014 106
 1st Floor, 191 Racecourse Road, Flemington, Victoria 3031
 P.O Box 240, North Melbourne, Victoria 3051
 Phone (03) 9371 2400 Fax (03) 9371 2499

TEST REPORT

Client : Selection Steel Trading
 64-66 Ventura Place
 Dandenong South VIC 3175

Test Number : 19-002186
Issue Date : 9/05/2019
Print Date : 9/05/2019

Ignition is initiated by a pilot flame that is held near, but does not touch the specimen. A material that does not ignite during the standard test may ignite if contacted with a pilot flame during the test.

Each test specimen had an unattached backing of 4.5mm thick fibre reinforced cement board.

Each test specimen was clamped in four places.

These results only apply to the specimen mounted, as described in this report. The result of this fire test may be used to directly assess fire hazard, but it should be recognised that a single test method will not provide a full assessment of fire hazard under all fire conditions.

165141

35632

Page 2 of 2

© Australian Wool testing Authority Ltd
 Copyright - All Rights Reserved



Accredited for compliance with ISO/IEC 17025 - Testing
 - Chemical Testing
 - Mechanical Testing
 - Performance & Approvals Testing

- Accreditation No. 983
 - Accreditation No. 985
 - Accreditation No. 1356



Samples and their identifying descriptions have been provided by the client unless otherwise stated. AWTA Ltd makes no warranty, implied or otherwise, as to the source of the tested samples. The above test results relate only to the sample or samples tested. This document shall not be reproduced except in full and shall be rendered void if amended or altered. This document, the names AWTA Product Testing and AWTA Ltd may be used in advertising providing the content and format of the advertisement have been approved by the Managing Director of AWTA Ltd.

0204/11/06

[Signature]
 APPROVED SIGNATORY

[Signature]
 MICHAEL A. JACKSON B.Sc.(Hons)
 MANAGING DIRECTOR

D.7 Coated Sheet Steel (UniCote 0.55mm) AS1530.3 Test Certificate

Certificate of Test

Quote No.: NE7651

REPORT No.: FNE11809A

AS/NZS 1530.3:1999 SIMULTANEOUS DETERMINATION OF IGNITABILITY, FLAME PROPAGATION, HEAT RELEASE AND SMOKE RELEASE

TRADE NAME: UniCote

SPONSOR: Selection Steel Trading Pty Ltd
64-66 Ventura Place
DANDENONG SOUTH VIC 3175
AUSTRALIA

DESCRIPTION OF SAMPLE:

The sponsor described the tested specimen as a pre painted steel product comprising of the following layers:
Layer 1: 18- μ \pm 2- μ paint finish coat
Layer 2: 7- μ \pm 1- μ chromate primer
Layer 3: 75-g/m² aluminium/zinc alloy coating
Layer 4: 0.55-mm steel core
Layer 5: 75-g/m² aluminium/zinc alloy coating
Layer 6: 5- μ \pm 1- μ primer
Layer 7: 5 μ \pm 1 μ Shadow Grey (standard colour) wash coat
Nominal total mass: 150-g/m²
Nominal thickness: 0.55-mm
Colour: Monolith (dark grey)

TEST PROCEDURE: Six samples were tested in accordance with Australian Standard 1530, Method for fire tests on building components and structures, Part 3: Simultaneous determination of ignitability, flame propagation, heat release and smoke release, 1999. For the test, each sample was clamped to the specimen holder in four places.

RESULTS: The following means and standard errors were obtained:

Parameter	Mean	Standard Error
Ignition Time (min)	N/A	N/A
Flame Spread Time (s)	N/A	N/A
Heat Release Integral	N/A	N/A
Smoke Release (log ₁₀ D)	-1.498	0.042

For regulatory purposes these figures correspond to the following indices:

Ignitability Index (0-20)	Spread of Flame Index (0-10)	Heat Evolved Index (0-10)	Smoke Developed Index (0-10)
0	0	0	2

The results of this fire test may be used to directly assess fire hazard, but it should be recognised that a single test method will not provide a full assessment of fire hazard under all fire conditions.

DATE OF TEST: 12 October 2016

Issued on the 25th day of October 2016 without alterations or additions. Supersedes Report No. FNE11809 issued on 17th day of October 2016.

Heherson Alarde
Testing Officer

Brett Roddy
Team Leader, Fire Testing and Assessments

Copyright CSIRO 2016 ©. Copying or alteration of this report without written authorisation from CSIRO is forbidden.



NATA Accredited Laboratory
Number: 165
Corporate Site No 3625
Accredited for compliance with ISO/IEC 17025

CSIRO INFRASTRUCTURE TECHNOLOGIES

14 Julius Avenue, Riverside Corporate Park, North Ryde NSW 2113 AUSTRALIA
Telephone: 61 2 9490 5444 Facsimile: 61 2 9490 5555 www.csiro.au



D.8 Coated Sheet Steel (UniZinc) AS1530.3 Test Certificate

AWTA PRODUCT TESTING

Australian Wool Testing Authority Ltd - trading as AWTA Product Testing
 A.B.N 43 006 014 106
 1st Floor, 191 Racecourse Road, Flemington, Victoria 3031
 P.O Box 240, North Melbourne, Victoria 3051
 Phone (03) 9371 2400

TEST REPORT

Client : Selection Steel Trading
 64-66 Ventura Place
 Dandenong South VIC 3175

Test Number : 20-000776
 Issue Date : 6/03/2020
 Print Date : 10/03/2020

Sample Description Clients Ref : "Uni Zinc"
 Rigid Panel
 Colour : Silver
 End Use : Roofing and Cladding
 Nominal Composition : Low carbon steel with metallic alloy coated substrate (nominal 50 micron total on both sides)
 Nominal Mass per Unit Area/Density : 7850 kg/m³
 Nominal Thickness : <1mm

AS/NZS 1530.3-1999

Methods for Fire Tests on Building Materials, Components and Structures
 Part 3: Simultaneous Determination of Ignitability,
 Flame Propagation, Heat Release and Smoke Release

Face tested:	Face		
Date tested:	06/03/2020		
	Standard Error	Mean	
Ignition time	Nil	Nil	min
Flame propagation time	Nil	Nil	sec
Heat release integral	Nil	Nil	kJ/m ²
Smoke release, log d	0.0929	-2.2106	
Optical density, d		0.0068	/ metre
Number of specimens ignited:		0	
Number of specimens tested:		6	
Regulatory Indices:			
Ignitability Index		0	Range 0-20
Spread of Flame Index		0	Range 0-10
Heat Evolved Index		0	Range 0-10
Smoke Developed Index		0-1	Range 0-10

196624 42460

Page 1 of 2

© Australian Wool Testing Authority Ltd
 Copyright - All Rights Reserved



Accredited for compliance with ISO/IEC 17025 - Testing
 - Chemical Testing : Accreditation No. 983
 - Mechanical Testing : Accreditation No. 985
 - Performance & Approvals Testing : Accreditation No. 1356



Samples and their identifying descriptions have been provided by the client unless otherwise stated. AWTA Ltd makes no warranty, implied or otherwise, as to the source of the tested samples. The above test results relate only to the sample or samples tested. This document shall not be reproduced except in full and shall be rendered void if amended or altered. This document, the names AWTA Product Testing and AWTA Ltd may be used in advertising providing the content and format of the advertisement have been approved by the Managing Director of AWTA Ltd.

0204/11/06

APPROVED SIGNATORY

MICHAEL A. JACKSON B.Sc. (Hons)
 MANAGING DIRECTOR

AWTA PRODUCT TESTING

Australian Wool Testing Authority Ltd - trading as AWTA Product Testing
 A.B.N 43 006 014 106
 1st Floor, 191 Racecourse Road, Flemington, Victoria 3031
 P.O Box 240, North Melbourne, Victoria 3051
 Phone (03) 9371 2400

TEST REPORT

Client : Selection Steel Trading
 64-66 Ventura Place
 Dandenong South VIC 3175

Test Number : 20-000776
Issue Date : 6/03/2020
Print Date : 10/03/2020

These results only apply to the specimen mounted, as described in this report. The result of this fire test may be used to directly assess fire hazard, but it should be recognised that a single test method will not provide a full assessment of fire hazard under all fire conditions.

The reaction of thin unsupported flexible materials to flame impingement can be assessed in accordance with AS 1530.2. Where materials of thickness less than 2mm that are sufficiently flexible to be bent by hand around a mandrel of 2mm diameter or less are subjected to the test described herein, they should also be subjected to the test in AS 1530.2.

Ignition is initiated by a pilot flame that is held near, but does not touch the specimen. A material that does not ignite during the standard test may ignite if contacted with a pilot flame during the test.

Each test specimen had an unattached backing of 4.5mm thick fibre reinforced cement board.

Each test specimen was clamped along all sides.

Smoke Developed Index is reported as 0-1 due to the inability of the smoke measurement equipment to resolve an index of zero.

196624

42460

Page 2 of 2

© Australian Wool Testing Authority Ltd
 Copyright - All Rights Reserved



Accredited for compliance with ISO/IEC 17025 - Testing

- Chemical Testing
 - Mechanical Testing
 - Performance & Approvals Testing

: Accreditation No. 983
 : Accreditation No. 985
 : Accreditation No. 1356



Samples and their identifying descriptions have been provided by the client unless otherwise stated. AWTA Ltd makes no warranty, implied or otherwise, as to the source of the tested samples. The above test results relate only to the sample or samples tested. This document shall not be reproduced except in full and shall be rendered void if amended or altered. This document, the names AWTA Product Testing and AWTA Ltd may be used in advertising providing the content and format of the advertisement have been approved by the Managing Director of AWTA Ltd.

0204/11/06

APPROVED SIGNATORY

MICHAEL A. JACKSON B.Sc (Hons)
 MANAGING DIRECTOR

D.9 Coated Steel Facings Bonded to Mineral Wool Core AS1530.3 Test Certificate

AWTA PRODUCT TESTING

Australian Wool Testing Authority Ltd - trading as AWTA Product Testing
 A.B.N 43 006 014 106
 1st Floor, 191 Racecourse Road, Flemington, Victoria 3031
 P.O Box 240, North Melbourne, Victoria 3051
 Phone (03) 9371 2400 Fax (03) 9371 2499

TEST REPORT

Client : Delta Panels Pty Ltd
 2828 Ipswich Road
 Darra QLD 4076

Test Number : 18-006075
 Issue Date : 14/11/2018
 Print Date : 14/11/2018

Sample Description Clients Ref : "DeltaCool - MW"
 Insulated Building Panels
 Nominal Composition : Pre-painted steel skins bonded to a mineral wool core
 Nominal Mass per Unit Area/Density : 100kg/m³
 Nominal Thickness : 125mm

AS/NZS 1530.3-1999

Methods for Fire Tests on Building Materials, Components and Structures Part 3: Simultaneous Determination of Ignitability, Flame Propagation, Heat Release and Smoke Release

Face tested:	Face	
Date tested:	13/11/2018	
	Standard Error	Mean
Ignition time	Nil	Nil min
Flame propagation time	Nil	Nil sec
Heat release integral	Nil	Nil kJ/m ²
Smoke release, log d	0.0142	-1.5719
Optical density, d		0.0269 / metre

Number of specimens tested: 6

Regulatory Indices:

Ignitability Index	0	Range 0-20
Spread of Flame Index	0	Range 0-10
Heat Evolved Index	0	Range 0-10
Smoke Developed Index	2	Range 0-10

147618

31470

Page 1 of 2

© Australian Wool Testing Authority Ltd
 Copyright - All Rights Reserved



Accredited for compliance with ISO/IEC 17025 - Testing

- Chemical Testing
 - Mechanical Testing
 - Performance & Approvals Testing

: Accreditation No. 983
 : Accreditation No. 985
 : Accreditation No. 1356



Samples and their identifying descriptions have been provided by the client unless otherwise stated. AWTA Ltd makes no warranty, implied or otherwise, as to the source of the tested samples. The above test results relate only to the sample or samples tested. This document shall not be reproduced except in full and shall be rendered void if amended or altered. This document, the names AWTA Product Testing and AWTA Ltd may be used in advertising providing the content and format of the advertisement have been approved by the Managing Director of AWTA Ltd.

0204/11/06

APPROVED SIGNATORY

MICHAEL A. JACKSON B.Sc (Hons)
 MANAGING DIRECTOR

Appendix E Bonded Laminate Panels



Our Reference: S6637

28/08/2020

Delta Panels
2828 Ipswich Rd

Darra QLD 4076

Attention: Todd Guy

Delta Panels [Mineral Wool Panels]

Dear Todd,

In reviewing the National Construction Code of Australia (2019), Section C1.9 (e) we note that materials may be used wherever a non-combustible material is required a bonded laminated material may be used where three criteria are met. Below, we address each of the requirements in turn, and the evidences provided that we have been supplied with that support our final observation:

Delta Panel Mineral wool products are made from laminates of pre-painted steel skins bonded to a mineral wool core.

1. Each lamina, including any core, is non-combustible
 - 1.1. CSIRO Infrastructure Technologies, Certificate of Test Report FNC12604 dated 24 July 2020 for the Delta panels mineral wool / rockwool designated the material as not combustible according to the test criteria in Clause 3.4 of AS1530.1-1994
2. Each adhesive layer does not exceed 1mm in thickness and the total thickness of the adhesive layers does not exceed 2mm; and
 - a. The insulated panels are laminated under pressure with the thickness of adhesive being less than 1.0mm on each face. This observation is based on examining an example calibration test for the gluing that indicates a thickness of adhesive on each face less than 1.0mm. As the panels have a steel face cladding with a thickness in the order of 1mm thick, an adhesive layer that was 1mm thick would be visibly distinct from the face sheeting. That this is not evident is another evidence of the panel's compliance.
3. The spread of flame index and smoke developed index of the bonded laminated material as a whole does not exceed 0 and 3 respectively.
 - a. AWTA Product testing report 18-006075 dated 14 November 2018 covering Delta Panels Mineral wool panels states:

i. Spread of Flame index	= 0
ii. Smoke Developed Index	= 2

The two reports referenced are appended to this letter.

Based on the three above evidences and observations I certify that the Delta Panels Mineral Wool panels meet the three performance criteria outlined in the NCC (2019) Section C1.9 (non-combustible building elements)

Yours Sincerely

Milanovic Neale Consulting Engineers
Andrew Morrison
Senior Structural Engineer RPEQ 12942 VBA-EC 43836
amorrison@mnce.com.au

**CIVIL
STRUCTURAL
PROJECT MANAGEMENT**
W mnce.com.au ABN 68 678 825 458

BRISBANE OFFICE
5/63 Annerley Road, Woolloongabba QLD 4102
PO Box 8380, Woolloongabba QLD 4102
T 07 3255 1877 F 07 3255 1878

IPSWICH OFFICE
18 Canning Street, North Ipswich QLD 4305
PO Box 2118, North Ipswich QLD 4305
T 07 3281 6603 F 07 3281 6602

Appendix F AS 3959-2009 Fire Test Certificate



Fire Test Certificate

This is to certify that the specimen described below has been examined by BRANZ Ltd on behalf of

Delta Panels Pty Ltd
2828 Ipswich Road
Darra
Brisbane, 4076
Australia

Test standard: AS 3959-2009

Specimen name: DeltaCool wall system, DeltaTrim, and DeltaOrb roof systems

Specimen description: Delta Panels Pty Ltd DeltaCool wall and DeltaTrim and DeltaOrb roofing systems, steel sandwich panels of expanded polystyrene (EPS) core up to 150 mm thick. The steel facings are 0.40 mm or 0.6 mm BMT with a flat, trapezoidal or corrugated profile. There is a steel end cap encapsulating the EPS.

Orientation: Exposure on the external surface

A full description of the test specimen and the test results are given in BRANZ Test Reports and Assessments:

BRANZ Fire Assessment Report FC10893-001

Conditions of laboratory registration by IANZ do not allow assessments by the Registered Laboratory to be covered by IANZ.

Regulatory authorities are advised to examine test reports before approving any product.

The assessed results were as follows:

DeltaCool wall system - BAL-29
DeltaTrim and DeltaOrb roofing systems - BAL-40

Certificate issued: 24 October 2018

Certificate Number: 805

E Soja
Senior Fire Engineer
For BRANZ Limited



This Laboratory is accredited by International Accreditation New Zealand (IANZ). The tests reported herein have been performed in accordance with the laboratory's scope of accreditation.

The National Association of Testing Authorities (NATA) and International Accreditation New Zealand (IANZ) are both signatories of the ILAC Mutual Recognition Agreement.



The following statement is required by the test standard "This certificate is provided for general information only and does not

Appendix G Accreditation

NATIONAL PROFESSIONAL ENGINEERS REGISTER

Registered Professional Engineer

This is to certify that:
Paul Clancy
MIEAust CPEng

has been registered in the following areas of practice from the dates shown

Structural (general)	27/02/2007
Fire Safety Engineering	27/02/2007

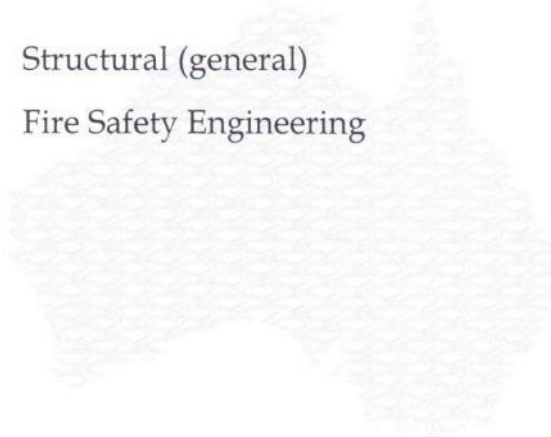

Chair, National Engineering Registration Board

Registrar, National Engineering Registration Board

Government, community and profession cooperating to maintain national registers in the community interest

For details see - <http://www.nerb.org.au>



The Association of Consulting Engineers Australia



THE ASSOCIATION OF PROFESSIONAL ENGINEERS, SCIENTISTS AND MANAGERS, AUSTRALIA



Certificate NOT valid without current membership card that states "National Professional Engineers Register (NPER)" against "REGISTRATION" in the left-hand column.

This certificate is evidence that at the time of assessment the person named on the certificate demonstrated the qualifications and experience to practice competently in the stated area(s) of practice.

When taken in conjunction with a current practice card the certificate also provides evidence of continued practice in the stated area(s) and a commitment to ethical standards and continuing professional development that is satisfactory to the profession.



NPER

NATIONAL PROFESSIONAL ENGINEERS REGISTER

136936

The National Professional Engineers Register is administered by

The Institution of Engineers, Australia

(This certificate does not imply membership of any of the sponsoring professional bodies)

Appendix H Company Profile

1. Contact Details

Address	24 Watts Drive Varsity Lakes Qld 4227
Phone	07 5562 0022
Mobile	0439 632 886
Fax	07 5562 1466
Email	sotera@sotera.com.au
Web	www.sotera.com.au



2.0 Overview of Company

Sotera specialises in fire risk engineering. The consultancy does not design building services and thus does not have its interests comprised in recommending a cost-effective safe combination of fire services. The director of the company has been practising in Queensland and New South Wales for the past five years and since 1990 generally including research and consulting for overseas interests. It has successfully undertaken over 300 projects of all types with a near perfect approval record. The company is highly respected by QFRS and other building professionals. It is often invited onto challenging projects and to give seminars to professional institutes.

3.0 Staff

Dr Paul Clancy – Director, fire and structural engineering (PhD-fire, MEngSc – Struc Mgt)
Mr Neelesh Chandiran – Fire and electrical engineering, BEng (Elec). MEng (Elec) MEng (Mgt)

4.0 Accreditations:

NPER Fire, Structures, CPEng, MIEAust – one of six in Queensland.
RPEQ Fire Structural registration number 10045
NSW Registration with Building Professionals Board C-10 Accredited Certifier – Fire Safety Engineering No BPB0747
Victoria Fire Safety Engineer EF 30459

5.0 Projects

Featured High Rise Buildings Classes 2, 3, 5, 6, 7a

Soul: 75 storeys, Surfers Paradise
Hilton Hotel Surfers Paradise, two towers 35 and 55 storeys on 5 level car park basement.
The Oracle, Broadbeach: two towers 40 and 50 storeys on common podium
Southport Central 2 and 3: two 40 storey towers on a 6 level basement car park

Featured Medium Rise Buildings Classes 2, 3, 5, 6, 7a, 9b

Riverpoint, West End, Brisbane: several apartment buildings to 6 and 7 storeys on a common basement car park.
16-18 Eden Avenue, Rainbow Bay: 9 storey apartment building
Emerald Lakes: several buildings to 9 storeys, offices, apartments, shops

Community Housing Projects

Brisbane Housing Company, Masters Street Newstead, 6 storey housing commission – smoke doors deleted from long corridors

Brisbane Housing Company, Danby Lane, Nundah, 6 storeys open balconies and stairs
 Elliot Avenue, Caboolture – travel distance extended from 6 to 20 m.
 Tree Tops, Burleigh Waters – apartments, 8 storeys, travel distance to exit extended from 6 to 20 m by means of ventilation
 Bond University Student Accommodation six storeys

Featured Aged care

Tall Trees Rochedale
 Grande Pacific, 25 storeys
 Stage 15 Gardens on Lindfield, Helensvale

Shopping Centres

Sandgate Shopping Centre, Bowser Road
 Harvey Norman, Village Square Browns Plains

 Novo Northlakes

 Bargara Shopping Centre

 South Gympie

 Nerang Fair

Hospitals

Royal Brisbane Womens Hospital
 Bundaberg Hospital – Emergency and Maternity
 North West Hospital Redevelopment, Stage 4

Warehouses

Repcos Brisbane Airport
 Toll Express, Brisbane Airport
 Rivergate Boat Storage Facility
 Billabong, Burleigh Heads
 Lot 130 Days Rd, Upper Coomera

Other Featured Projects

Mackay Convention Centre
 HMAS Penguin diving bases in Sydney
 University of Southern Queensland, Springfield Campus
 Quad Park sports stadium – rationalization of FRL's, EVACNET study
 Southport Marina

6.0 Issues

Separation of united buildings, rationalization of sprinklers, stairs and lifts in same shaft safe zones, travel distances, non-fire-isolated stairs through 3 or 4 levels, combined hydrant sprinkler flows, proximity to boundary, rationalisation of FRL's, discharge past windows, discharge of fire isolated exit not direct to open space, stair widths and overall building evacuation, deletion of sprinklers in car parks with non-compliant ventilation, deletion of stair pressurization, single exits

7.0 Research – Paul Clancy

1986-2006 Research and consulting senior lecturer Victoria University – projects for Forintek Canada, National Research Council Canada, Canadian Defense, National Assoc Forest Ind Australia, American Forest & Paper, Swedish Timber Research, National Building Fire Safety Systems Code, Australia, project coordinator. 35 papers (most reviewed) in major reports, international conferences, international journals in fire safety engineering including Fire Safety Journal, Fire and Materials, Fire Technology, and Fire Protection Engineering Journal.

Supervision of Masters and PhD students. \$700,000 in research grants (2/3 as an individual effort, 1/3 with a group)